



# MPOD HV& LV Power Supply System

---

## Technical Manual

### **General Remarks**

The only purpose of this manual is a description of the product. It must not be interpreted as a declaration of conformity for this product including the product and software.

**W-Ie-Ne-R** revises this product and manual without notice. Differences of the description in manual and product are possible.

**W-Ie-Ne-R** excludes completely any liability for loss of profits, loss of business, loss of use or data, interrupt of business, or for indirect, special incidental, or consequential damages of any kind, even if **W-Ie-Ne-R** has been advised of the possibility of such damages arising from any defect or error in this manual or product.

Any use of the product which may influence health of human beings requires the express written permission of **W-Ie-Ne-R**.

Products mentioned in this manual are mentioned for identification purposes only. Product names appearing in this manual may or may not be registered trademarks or copyrights of their respective companies.

No part of this product, including the product and the software may be reproduced, transmitted, transcribed, stored in a retrieval system, or translated into any language in any form by any means with the express written permission of **W-Ie-Ne-R**.

### **Control Cabinet**

In the context of this user manual, the control cabinet must fulfill the requirements on fire-protective enclosures according to EN 60950 / IEC 60950 / UL 60950.

All devices are intended for operation in control cabinets or in closed areas. The LAN connection and all wire connections between the different system parts must be done via shielded cable with conductive connector shells, which are fixed with screws.

Furthermore, an additional fire-protective enclosure is required which must not affect proper air circulation.

## Mains Voltage and Connection

The Power supplies are equipped with a "World"- mains input (rated voltage range: 100-240 VAC, frequency: 50-60 Hz, rated current: 16 A). Before connecting to the mains please double-check correspondence.

Mains input connection at the power supply side is done with a 3-pin HIRSCHMANN connector or power terminals. There is no main fuse inside. A circuit breaker for overcurrent protection 16A, type B or C (EN / IEC 60898, VDE 0641), has to be installed externally.

Before disconnection the HIRSCHMANN connector, the power supply should be switched into standby state. (Use the ON/OFF-Switch of the front pannel of the MPOD system)

Hirschmann.	Signal	Description	Color of the Wire
Pin 1	L	Phase	black or brown
Pin 2	N	Return, Neutral	blue
Pin 3		not connected	
Earth	PE	Protective Earth	green/yellow

## Connection to Earth

### Safety

After connecting the Power box to the mains, the mains input module is powered permanently. Filter and storage capacitors of the power factor correction module are charged with about **400VDC**. Any DC-On-Signal as well as a power switch at control board (if any installed) operates as a low voltage DC on/off switch only and not as a mains breaker. **Therefore it becomes dangerous if the box cover is open. In this case a lot of components on high voltage potential get touchable!**

**Before starting any kind of work inside the power box remove the unit from mains and wait a couple of minutes with your activities! Discharge the primary DC Filter-capacitors by use of a well isolated 22 ohm 10W resistor.**

**We recommend in case of any malfunction to send the power box to Wiener or to one of our representative for service**



**The backplane is connected to 385 V DC voltage. So never touch the backplane or its connectors!**

**The HV-Modules produce very high voltage which may be mortal danger if handled improperly. Please read the separate manuals of the HV modules for detailed information!**

## Declaration of Conformity

Low Voltage Directive 73/23/EEC and EMC Directive Art. 10.1 of 89/336/EEC

# W-I-E-N-E-R

Plein & Baus GmbH

---

declare under our own responsibility that the product

## MPOD Power Supply System

Items: 0MPV.xxxx, 0BP0.9003, 0316.0070, 0R00.0002

is in accordance with the following standards or standardized documents:

- |    |  |  |
|----|--|--|
| 1. | <b>EN 60 950-1:2001</b><br>+ Corr:2004-09  | Niederspannungsrichtlinie [low voltage directive]  |
| 2. | <b>EN 61 000-6-3:2001</b><br><br>EN 55 022:1998<br>+ Corr:2001 + A1:2000 Kl. B<br>EN 55 022:1998<br>+ Corr:2001 + A1:2000 Kl. B<br>EN 61 000-3-2:2001<br>EN 61 000-3-3:1995 +Corr:1997<br>+A1:2001   | Störaussendung EMA [RF emission]<br>Störspannung [conducted noise]<br><br>Störfeldstärke [radiated noise]  |
| 3. | <b>EN 61 000-6-2:2001</b><br>EN 61 000-4-6:1996 + A1:2001<br>EN 61 000-4-3:1996 + A1:1998 + A2:2001<br>EN 61 000-4-4:1995 + A1:2001<br>EN 61 000-4-5:1995 + A1:2001<br>EN 61 000-4-11:1994 + A1:2000<br><br>EN 61 000-4-2:1995 + A1:1998 + A2:2001 | Oberschwingungen [harmonics]<br>Spannungsschwankungen [flicker]<br><br><b>Störfestigkeit EMB [immunity]</b><br>HF-Einströmung [injected HF currents]<br>HF-Felder [radiated HF fields] incl. "900MHz"<br>Burst<br>Surge<br>Spannungs-Variationen [voltage variations]<br>ESD |

Conditions:

---

This unit is not a final product and is foreseen for use inside a closed cabinet. The supplying of loads over long distances (>3m) needs possibly additional RF rejection hardware to get in conformity of the definition.

Name and signature of authorized person

Manfred Plein

Techn. Director  
April 2008

Place and Date

# Contents

Declaration of Conformity.....	iii
<b>1 General Information.....</b>	<b>1</b>
1.1 Mpod Features .....	1
1.2 Mpod Crate - standard types.....	2
1.3 Mpod Mini crate.....	3
<b>2 LV Modules.....</b>	<b>4</b>
2.1 MPOD Low Voltage Module Versions.....	5
2.2 Combined Power & Sense Connector Pin Assignment (standard female type).....	5
2.3 Sense & Control Connector Pin Assignment (modules with mixed DSUB37 + DSUB37-8).....	7
2.4 Power Connector Pin Assignment (modules with mixed DSUB37 + DSUB37-8).....	8
<b>3 HV Modules .....</b>	<b>9</b>
<b>4 Mpod Controller.....</b>	<b>13</b>
<b>5 Local Control .....</b>	<b>15</b>
5.1 Introduction.....	15
5.2 Usage of the rotary controls.....	15
5.3 MPOD Display Main menu.....	16
5.4 MPOD Display CHANNEL menu.....	17
<b>6 Remote Control / Software.....</b>	<b>19</b>
6.1 Software Setup for Microsoft Windows.....	19
6.2 Web Browser.....	21
6.3 NetSNMP.....	22
6.4 ISEG High voltage module special commands.....	28
6.5 Change of community names / setting of passwords.....	33
6.6 MIB Browser.....	34
6.7 A BASH Simple Script for SNMP.....	35
6.8 Mpod SNMP Parameter List (most common).....	36
6.9 LabView Control Program (NETSNMP).....	37
6.10 C++ programming (NetSNMP).....	37
<b>7 Mpod Crate.....</b>	<b>40</b>
<b>8 Primary Power Supply.....</b>	<b>40</b>
8.1 Power Box Data Sheet.....	40
<b>9 Mpod Low Voltage module MPV 8xx data sheet.....</b>	<b>41</b>
<b>10 SNMP examples for MPOD and high voltage EHS/EDS module.....</b>	<b>44</b>
<b>11 WIENER SNMP Parameter structure.....</b>	<b>46</b>
<b>12 MPOD Controller Firmware Update.....</b>	<b>55</b>
<b>13 MPOD Display Firmware Update.....</b>	<b>59</b>

**Figures**

**Tables**

# 1 General Information



## 1.1 Mpod Features

Mpod is a mainframe for multi-channel high voltage (HV) and low voltage (LV) power supply modules. A unique flexibility is given by outfitting the MPOD crate with either the LV or HV backplane only or with both to allow combined use of LV and HV modules. The full size Mpod crate has 10 slots for power modules which provides a high number of output channels. Its modular design makes the customer able to easily replace the fan tray, the controller, the primary power supply or the optional air filter.

- 10 module slots for up to 80 LV channels / up to 320 HV channels
- 8U high for bottom cooling air intake, optional 9U high as desktop or front / side intake with 1U dust filter
- Modules and controller outputs can be placed either at front or rear side (picture above shows front side)
- LV: 8 channels (0- 8/16/30/60V/120V, 50W / channel, floating)
- HV: 320/160/80 or 40 channels (0- 2,5/4/6kV/8kV/10kV), channel- or module wise floating or common ground
- Low noise and ripple
- Individually controlled output channels (voltage and current), programmable warning and trip levels
- MPOD Controller with Ethernet (TCP/IP) / CANbus / USB Combi-interface, Interlock
- Ethernet port with integrated Web server, programmable with SNMP protocol via TCP/IP, OPC Server

- CE conform EN 50 081/82 part 1 (EN 50 022 B)
- safety in accordance with EN 60 950
- Sinusoidal mains current EN 61000-3-2

## 1.2 Mpod Crate - standard types

The following crate types are standardized configurations with 8U high chassis. Optionally a filter frame is available with bottom or front air inlet which increases the height to 9U.

Other configurations and mixed system with part of the crate outfitted with PCI or VME backplanes are available on request.

Type	Slots	Remote control interface	Local control / Backplane display	HV	HV power	Output Position
Mpod EC	10	Ethernet, CAN, USB	-	HV/LV	600W	front
Mpod EC-R	10	Ethernet, CAN, USB	-	HV/LV	600W	rear
Mpod LX	10	Ethernet, CAN, USB	Yes, LCD	HV/LV	600W	front
Mpod LX-R	10	Ethernet, CAN, USB	Yes, LCD	HV/LV	600W	rear
Mpod EC-LV	10	Ethernet, CAN, USB	-	LV	-	front
Mpod EC-LV-R	10	Ethernet, CAN, USB	-	LV	-	rear
Mpod EC-HV	10	Ethernet, CAN, USB	-	HV	600W	front
Mpod EC-HV-R	10	Ethernet, CAN, USB	-	HV	600W	rear
Mpod 2H	10	Ethernet, CAN, USB	-	HV	1200W	front
Mpod 2H-R	10	Ethernet, CAN, USB	-	HV	1200W	rear
Mpod 2H-LX	10	Ethernet, CAN, USB	Yes, LCD	HV	1200W	front
Mpod 2H-LX-R	10	Ethernet, CAN, USB	Yes, LCD	HV	1200W	rear

(CAN-bus for HV modules only, disabling Ethernet communication may be necessary for ISEG CAN-HV control software)



Mpod EC-LV crate with low voltage modules

Optionally, Mpod can be outfitted with a removable 1U tray for frontal air inlet and air filter underneath the bin, as in the picture:



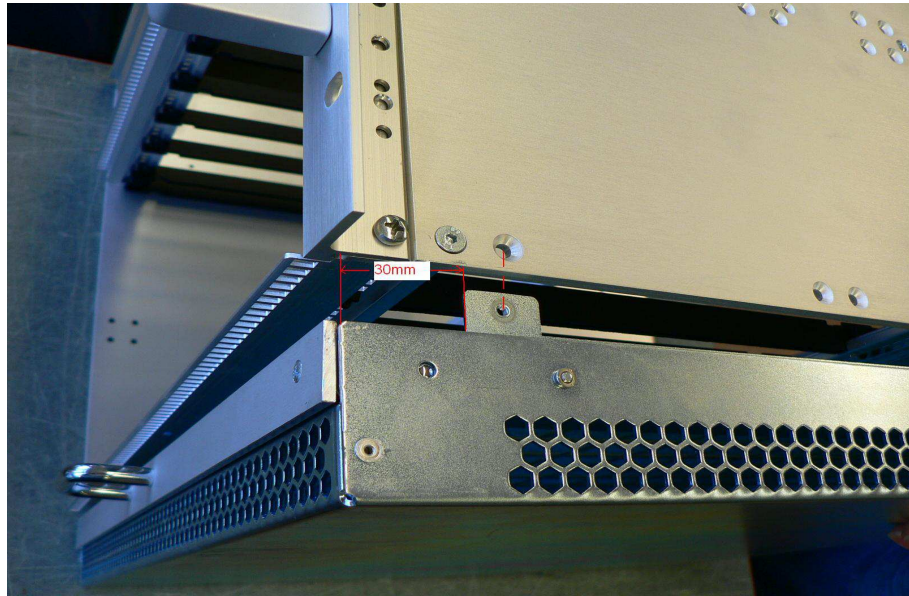

### 1.3 Mpod Mini crate

The WIENER Mpod mini crate represents a compact 19" rack mountable chassis for up to 4 Mpod low and high voltage modules. The Mpod mini crate includes the primary power supply with 600W power for high voltage modules as well as a cooling system with high performance DC fan. It can be outfitted with HV backplane for use as a high voltage system only or with both HV and LV backplanes.

The first half slot is reserved for the Mpod Controller which manages the primary power supplies and provides Ethernet, USB and CAN-bus interfaces for remote monitoring and control. Please note that it is possible to switch the Mpod crate off and on off remotely when the front panel switch is in ON position.



Mpod Mini crate with Mpod controller and 2 high voltage + 2 low voltage modules

## 2 LV Modules

The MPV Mpod Low Voltage modules are available with either 4 or 8 channels for different voltage ranges with 8V, 16V, 30V, 60V maximum respectively. Special modules with up to 120V are under development.

All MVP modules have the following features:

- 6U height, 220mm deep fully shielded mechanics
- All DC outputs with individual return lines, individually sensed, floating channel to channel and channel to chassis ground (125V, 500V tested)
- Low noise and ripple
- Voltage and current settings / monitoring for each channel, 15 bit resolution, accuracy +/-0.1% of full scale value
- Current monitoring and limiting for each channel, 15 bit resolution, accuracy +/-0.05% of full scale value
- high stability, 0.2%/10k
- Programmable channel parameters:
  - voltage, under voltage / over voltage trip point
  - current limit
  - power, regulation type, internal / external sense
  - ramping speed up and down (1V/s ... 500V/s)
  - group features / error handling
- programming and monitoring via Ethernet (TCP/IP) and USB
- Connectors: 2 x 8 pin high current sub-D, 37 pin sub-D for sense / control or 2 x 37 pin sub-D for DC and sense (4 channels each)

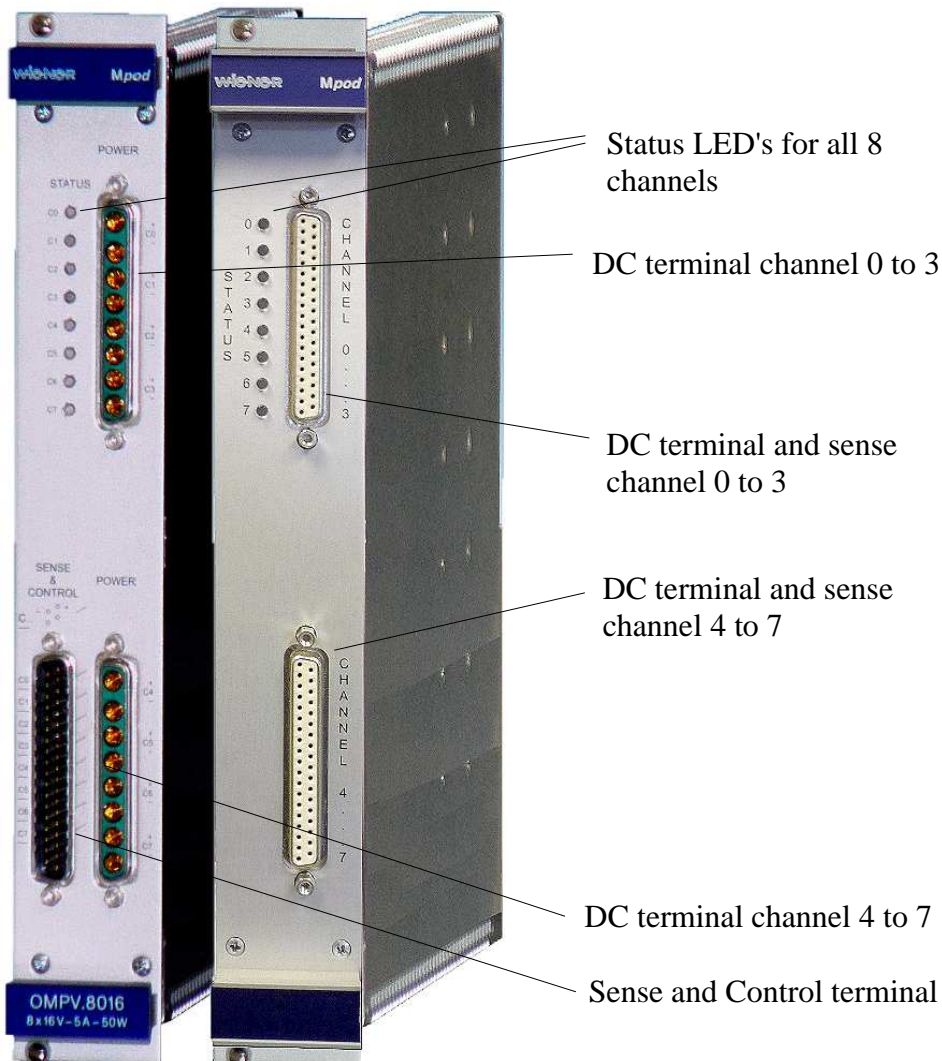

## 2.1 MPOD Low Voltage Module Versions

### MPOD Low Voltage Series, 2 or 8 channels with floating ground

Type	Channels	Voltage	I Max	Peak Power	V-Res	I-Res	Ripple
MPV 2008	2	0 to 8V	40A	200W / ch.	0.5mV	0.25mA	<10mVpp
MPV 2016	2	0 to 15V	20A	200W / ch.	1mV		<10mVpp
MPV 2030	2	0 to 30V	10A	200W / ch.	15bit		<10mVpp
MPV 2060	2	0 to 60V	5A	200W / ch.	15bit		<10mVpp
MPV 8008D	8	0 to 8V	10A	50W / ch.	0.5mV	0.5mA	<30mVpp
MPV 8008I	8	0 to 8V	10A	50W / ch.	0.5mV	0.5mA	<30mVpp
MPV 8008LD	8	0 to 8V	5A	40W / ch.	0.5mV	0.25mA	<10mVpp
MPV 8008LI	8	0 to 8V	5A	40W / ch.	0.5mV	0.25mA	<10mVpp
MPV 8016D	8	0 to 15V	5A	50W / ch.	1mV	0.25mA	<10mVpp
MPV 8016I	8	0 to 15V	5A	50W / ch.	1mV	0.25mA	<10mVpp
MPV 8030D	8	0 to 30V	2.5A	50W / ch.	2mV	0.12mA	<10mVpp
MPV 8030I	8	0 to 30V	2.5A	50W / ch.	2mV	0.12mA	<10mVpp
MPV 8060D	8	0 to 60V	1A	50W / ch.	4mV	0.06mA	<10mVpp
MPV 8060I	8	0 to 60V	1A	50W / ch.	4mV	0.06mA	<10mVpp
MPV 8120D	8	0 to 120V	100mA	50W / ch.	4mV	4 μA	<10mVpp
MPV 8120I	8	0 to 120V	100mA	50W / ch.	4mV	4 μA	<10mVpp

**L** = Low noise;

**D** = Sub **D** 37 pin female connector;

**I** = Interlock, with sub **D** 37 pin female connector.

#### MPOD Low Voltage mating connectors

Sub-D 37 male connector	8	4-channel combined power/sense Sense for 8 channels
Sub-D 8 female (high current)	8	Special version with 40A contacts
Sub-D 37 extension cable 5m	37	Combined power/sense for 4 channels
Sub-D 37 extension cable 25m	37	Combined power/sense for 4 channels

Connectors are **IEC807-3/DIN41652** conform. Custom made cable sets are available on request.

## 2.2 Combined Power & Sense Connector Pin Assignment (standard female type)

### Top connector

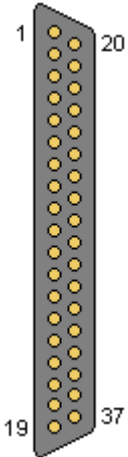
DSUB37 female (Channel 0..3)	Pin	Signal	Comment
	1	U0-	Channel 0 negative output
	20	U0+	Channel 0 positive output
	2	U0-	Channel 0 negative output
	21	U0+	Channel 0 positive output
	3	U0-	Channel 0 negative output
	22	U0+	Channel 0 positive output
	4	S0-	Channel 0 negative sense input
	23	S0+	Channel 0 positive sense input
	5	U1-	Channel 1 negative output
	24	U1+	Channel 1 positive output
	6	U1-	Channel 1 negative output
	25	U1+	Channel 1 positive output
	7	U1-	Channel 1 negative output
	26	U1+	Channel 1 positive output
	8	S1-	Channel 1 negative sense input
	27	S1+	Channel 1 positive sense input
	9	U2-	Channel 2 negative output
	28	U2+	Channel 2 positive output
	10	U2-	Channel 2 negative output
29	U2+	Channel 2 positive output	
11	U2-	Channel 2 negative output	
30	U2+	Channel 2 positive output	
12	S2-	Channel 2 negative sense input	
31	S2+	Channel 2 positive sense input	
13	U3-	Channel 3 negative output	
32	U3+	Channel 3 positive output	
14	U3-	Channel 3 negative output	
33	U3+	Channel 3 positive output	
15	U3-	Channel 3 negative output	
34	U3+	Channel 3 positive output	
16	S3-	Channel 3 negative sense input	
35	S3+	Channel 3 positive sense input	
17	INTERLOCK0	Optional interlock input: The four channels of this connector are	
36	INTERLOCK1	enabled only if a signal is applied here	
18	LOOP0	Safety Loop, LOOP0 and LOOP1 are connected to each other, no	
37	LOOP1	connection to other potentials	
19	CHASSIS	Connected to chassis / front panel	

### Bottom Connector

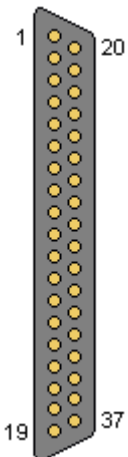
DSUB37 female (Channel 4..7)	Pin	Signal	Comment
	1	U4-	Channel 4 negative output
	20	U4+	Channel 4 positive output
	2	U4-	Channel 4 negative output
	21	U4+	Channel 4 positive output
	3	U4-	Channel 4 negative output
	22	U4+	Channel 4 positive output
	4	S4-	Channel 4 negative sense input
	23	S4+	Channel 4 positive sense input
	5	U5-	Channel 5 negative output
	24	U5+	Channel 5 positive output
	6	U5-	Channel 5 negative output
	25	U5+	Channel 5 positive output
	7	U5-	Channel 5 negative output
	26	U5+	Channel 5 positive output
	8	S5-	Channel 5 negative sense input
	27	S5+	Channel 5 positive sense input
	9	U6-	Channel 6 negative output
	28	U6+	Channel 6 positive output
	10	U6-	Channel 6 negative output
29	U6+	Channel 6 positive output	
11	U6-	Channel 6 negative output	
30	U6+	Channel 6 positive output	
12	S6-	Channel 6 negative sense input	
31	S6+	Channel 6 positive sense input	
13	U7-	Channel 7 negative output	
32	U7+	Channel 7 positive output	
14	U7-	Channel 7 negative output	
33	U7+	Channel 7 positive output	
15	U7-	Channel 7 negative output	
34	U7+	Channel 7 positive output	
16	S7-	Channel 7 negative sense input	
35	S7+	Channel 7 positive sense input	
17	INTERLOCK0	Optional interlock input: The four channels of this connector are	
36	INTERLOCK1	enabled only if a signal is applied here	
18	LOOP0	Safety Loop, LOOP0 and LOOP1 are connected to each other, no	
37	LOOP1	connection to other potentials	
19	CHASSIS	Connected to chassis / front panel	

## 2.3 Sense & Control Connector Pin Assignment (modules with mixed DSUB37 + DSUB37-8)

DSUB37 male (Channel 0..7)	Pin	Signal	Comment
	1	S0+	Channel 0 positive Sense Input
	20	S0-	Channel 0 negative Sense Input
	2		reserved
	21		reserved
	3	S1+	Channel 1 positive Sense Input
	22	S1-	Channel 1 negative Sense Input
	4		reserved
	23		reserved
	5	S2+	Channel 2 positive Sense Input
	24	S2-	Channel 2 negative Sense Input
	6		reserved
	25		reserved
	7	S3+	Channel 3 positive Sense Input
	26	S3-	Channel 3 negative Sense Input
	8		reserved
	27		reserved
	9	S4+	Channel 4 positive Sense Input
	28	S4-	Channel 4 negative Sense Input
	10		reserved
	29		reserved
	11	S5+	Channel 5 positive Sense Input
	30	S5-	Channel 5 negative Sense Input
	12		reserved
	31		reserved
	13	S6+	Channel 6 positive Sense Input
	32	S6-	Channel 6 negative Sense Input
	14		reserved
	33		reserved
	15	S7+	Channel 7 positive Sense Input
	34	S7-	Channel 7 negative Sense Input
	16		reserved
	35		reserved
	17		reserved
	36		reserved
	18		reserved
	37		reserved
	19		reserved

Some pins are reserved for future functionality.

## 2.4 Power Connector Pin Assignment (modules with mixed DSUB37 + DSUB37-8)

DSUB37-8 female (Channel 0..3)	Pin	Signal	Comment
	1	U0+	Channel 0 positive Output
	2	U0-	Channel 0 negative Output
	3	U1+	Channel 1 positive Output
	4	U1-	Channel 1 negative Output
	5	U2+	Channel 2 positive Output
	6	U2-	Channel 2 negative Output
	7	U3+	Channel 3 positive Output
	8	U3-	Channel 3 negative Output

DSUB37-8 female (Channel 4..7)	Pin	Signal	Comment
	1	U4+	Channel 4 positive Output
	2	U4-	Channel 4 negative Output
	3	U5+	Channel 5 positive Output
	4	U5-	Channel 5 negative Output
	5	U6+	Channel 6 positive Output
	6	U6-	Channel 6 negative Output
	7	U7+	Channel 7 positive Output
	8	U7-	Channel 7 negative Output

### Matching cable plug:

e.g. Erni TMC – P - 8W8 male, unloaded connector (103448) + pins

<http://www.erni.com/DB/PDF/TMC/ERNI-D-SubHighPower0101-e.pdf>

### 3 HV Modules

MPOD high voltage modules are manufactured by ISEG. For technical details please refer to the ISEG manuals and data sheets of the EHS, EBS, EDS and EHQ (discontinued) multi channel high voltage modules. General features are:

- High Voltage modules with 4, 8, 16 or 32 individually controlled channels
- Maximum voltage range from 500V up to 10 kV
- Extremely low noise and ripple: <5mVpp to <10mVpp
- All DC outputs floating or common ground depending on module type
- Voltage and current settings / monitoring for each channel, 16 to 21 bit resolution
- Current monitoring and limiting for each channel, 16 to 21 bit resolution
- Programmable channel parameters, group features
- output connectors:
  - 8 channel modules      SHV or REDEL (<4kV) multi pin  
                                 Kings for 8kV and 10kV (4 channels only)
  - 16 channel modules    SHV or REDEL (<4kV) multi pin
  - 32 channel modules    REDEL multi pin



ISEG high voltage modules with 4 channels KINGS (10kV), 8 and 16 channels SHV, and 8 / 16 channels REDEL multi-pin connectors (from left to right)

### EHS Series, 8/16 channels with common ground

Type	Channels	V max	I max	V res	I res	Ripple
EHS 40100x_504	4	10kV	0.5mA	20mV	1nA	<30mV
EHS 8080x_105	8	8kV	1mA	20mV	2nA	<30mV
EHS 8060x_105	8	6kV	1mA	12mV	2nA	<30mV
EHS 8040x_205	8	4kV	2mA	10mV	4nA	<10mV
EHS 8030x_305	8	3kV	3mA	10mV	5nA	<10mV
EHS 8020x_405	8	2kV	4mA	5mV	10nA	<10mV
EHS 8010x_805	8	1kV	8mA	2mV	20nA	<10 mV
EHS 8005x_156	8	500V	15mA	1mV	30nA	<10mV
EHS F040x_205	16	4kV	2mA	10mV	4nA	<10mV
EHS F030x_305	16	3kV	3mA	10mV	5nA	<10mV
EHS F020x_405	16	2kV	4mA	5mV	10nA	<10mV
EHS F010x_805	16	1kV	8mA	2mV	20nA	<10 mV
EHS F005x_156	16	500V	15mA	1mV	30nA	<10mV

### EHS Series, 8 / 16 channels with floating channels / ground

Type	Channels	V max	I max	V res	I res	Ripple
EHS 46100x_504	4	10kV	0.5mA	400mV	20nA	<30mV
EHS 8660x_105	8	6kV	1mA	240mV	40nA	<30mV
EHS 8640x_205	8	4kV	2mA	160mV	80nA	<10mV
EHS 8630x_305	8	3kV	3mA	120mV	120nA	<10mV
EHS 8620x_405	8	2kV	4mA	80mV	160nA	<10mV
EHS 8610x_805	8	1kV	8mA	40mV	320nA	<10 mV
EHS 8605x_156	8	500V	15mA	20mV	600nA	<10mV
EHS F640x_205	16	4kV	2mA	160mV	80nA	<10mV
EHS F630x_305	16	3kV	3mA	120mV	120nA	<10mV
EHS F620x_405	16	2kV	4mA	80mV	160nA	<10mV
EHS F610x_805	16	1kV	8mA	40mV	320nA	<10 mV
EHS F605x_156	16	500V	15mA	20mV	600nA	<10mV

### EHS High Precision Series, 8/16 channels (floating channels or common floating ground)

Type	Channels	V max	I max	V res	I res	Ripple
EHS 42100x_504 (F)	4	10kV	0.5mA	20mV	1nA/50pA	<30mV
EHS 8260x_105 (F)	8	6kV	1mA	12mV	1nA/50pA	<20mV
EHS 8240x_205 (F)	8	4kV	2mA	10mV	2nA/50pA	<5mV
EHS 8230x_305 (F)	8	3kV	3mA	10mV	3nA/50pA	<5mV
EHS 8220x_405 (F)	8	2kV	4mA	5mV	4nA/50pA	<5mV
EHS 8210x_805 (F)	8	1kV	8mA	2mV	5nA/50pA	<5 mV
EHS 8205x_106 (F)	8	500V	10mA	1mV	8nA/50pA	<5mV
EHS F240x_205 (F)	16	4kV	2mA	10mV	2nA/50pA	<5mV
EHS F230x_305 (F)	16	3kV	3mA	10mV	3nA/50pA	<5mV
EHS F220x_405 (F)	16	2kV	4mA	5mV	4nA/50pA	<5mV
EHS F210x_805 (F)	16	1kV	8mA	2mV	5nA/50pA	<5 mV
EHS F205x_106 (F)	16	500V	10mA	1mV	8nA/50pA	<5mV

### EHS High Density Series, 16 / 32 channels with common ground

Type	Channels	V max	I max	V res	I res	Ripple
EHS F1 40x_105	16	4kV	1mA	20mV	10nA	<10mV
EDS F1 30x_135	16	3V	1.3mA	15mV	13nA	<10mV
EDS F1 20x_205	16	2kV	2mA	10mV	20nA	<10mV
EDS F1 10x_405	16	1kV	4mA	5mV	40nA	<10mV



<b>EDS 20 025x_504</b>	32	4kV	1mA	20mV	10nA	<10mV
<b>EDS 21 030x_504</b>	32	3V	1.3mA	15mV	13nA	<10mV
<b>EDS 20 025x_504</b>	32	2kV	2mA	10mV	20nA	<10mV
<b>EDS 21 030x_504</b>	32	1kV	4mA	5mV	40nA	<10mV

**EDS Distribution Series, 16 / 32 channels with common ground**

<b>Type</b>	<b>Channe ls</b>	<b>V max</b>	<b>I max</b>	<b>V res</b>	<b>I res</b>	<b>Ripple</b>
<b>EDS F0 05x_105</b>	16	500V	1mA	5mV	20nA	<10mV
<b>EDS F0 05x_105</b>	16	2.5kV	0.5mA	10mV	10nA	<20mV
<b>EDS F1 30x_504</b>	16	3kV	0.5mA	10mV	100nA	<20mV
<b>EDS 20 005x_105</b>	32	500V	1mA	5mV	20nA	<10mV
<b>EDS 20 025x_504</b>	32	2.5kV	0.5mA	10mV	10nA	<20mV
<b>EDS 21 030x_504</b>	32	3kV	0.5mA	10mV	100nA	<20mV

**EBS Bipolar High voltage modules, 8 / 16 channels with common ground**

<b>Type</b>	<b>Channe ls</b>	<b>V max</b>	<b>I max</b>	<b>V res</b>	<b>I res</b>	<b>Ripple</b>
<b>EBS 80 05</b>	8	+ 500V	+ -1mA	5mV	20nA	<10mV
<b>EBS F0 05</b>	16	+ 500V	+ -1mA	5mV	20nA	<10mV
<b>EBS 80 30</b>	8	+ -3kV	+ - 0.5mA	10mV	100nA	<10mV
<b>EDS F0 30</b>	16	+ -3kV	+ - 0.5mA	10mV	100nA	<10mV

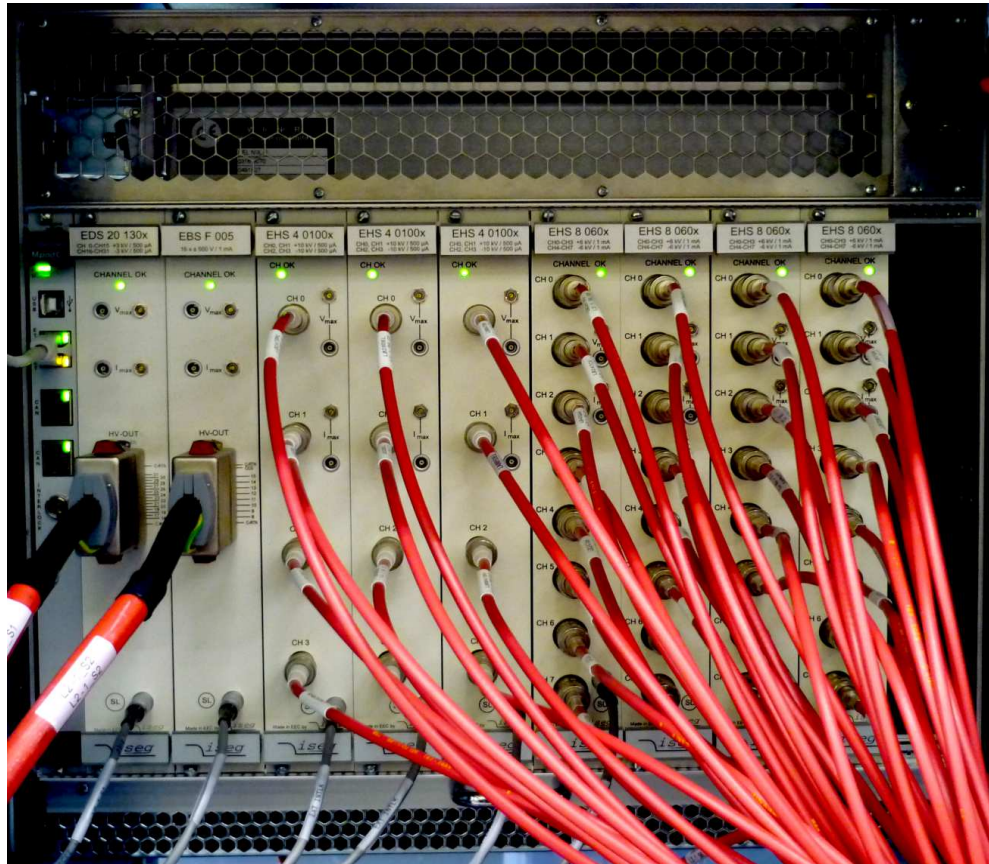

MPOD crate with rear side module option and air filter outfitted with ISEG EDS, EBS and EHS high voltage modules and wired safety loop.

## 4 Mpod Controller

The Mpod controller which is plugged into the first half slot of the crate controls the primary power supply as well as all inserted LV- and HV-modules. Further it connects these to remote controlling interfaces / services in a unique way.

Mpod Controller features:

- TCP/IP 10M/100M port, auto ranging
- Built-in HTTP server
- TCP/IP protocol with SNMP v.2c for full control of all module parameters
- 2 CAN-Bus ports, wired in parallel for daisy-chaining
- USB 2 interface
- 3 status LED's
- Interlock connector

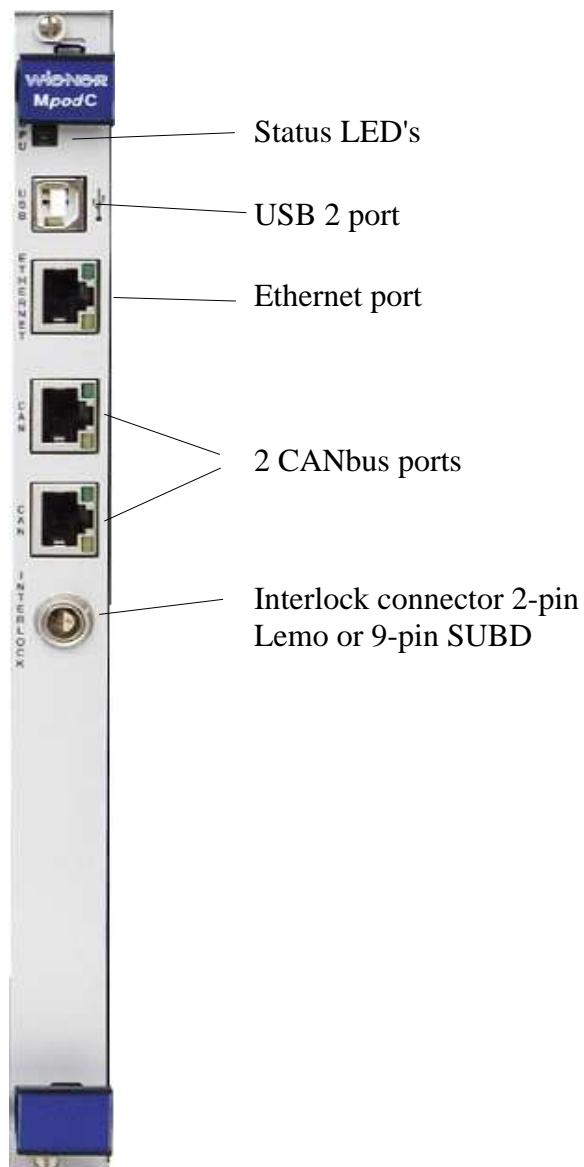

### Ethernet port, standard NIC pin layout

RJ45	Pin	Signal	Comment
	1	TX+	
	2	TX-	
	3	RX+	
	4	GND 1	75 Ohm
	5	GND 1	
	6	RX-	
	7	GND 2	75 Ohm
	8	GND 2	

### CAN-bus ports

RJ45	Pin	Signal	Comment
	1	CAN-H	
	2	CAN-L	
	3	GND	
	4	n.c.	
	5	n.c.	
	6	reserved	
	7	GND	
	8	n.c.	

### Interlock connector

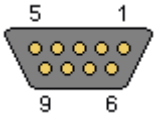
DSUB9 female	Pin	Signal	Comment
	1	CRATE_ENABLE	TTL input (1 kOhm resistor to GND) A high level allows the channels to be switched on by software A low level forces all channels to switch off with their specified down ramp.
	2	CRATE_FAST_OFF	TTL input (1 kOhm resistor to GND) A high level forces all channels to switch off as fast as possible. Any ramp-down settings are ignored.
	3	reserved	
	4	reserved	
	5	GND	Ground reference
	6	CRATE_STATUS	TTL output (1 kOhm resistor to GND, 100 Ohm resistor to protect the output buffer) This signal is driven high, if one or more channels of the MPOD system do have a non-zero output voltage
	7	reserved	
	8	reserved	
	9	reserved	

## 5 Local Control

### 5.1 Introduction

MPOD can be optionally equipped with a local color graphic display and two rotary controls.

### 5.2 Usage of the rotary controls

Please note that the display function and operation changed with MOD firmware 1.1.2021.

Connecting MPOD to the AC line will show the following screen:

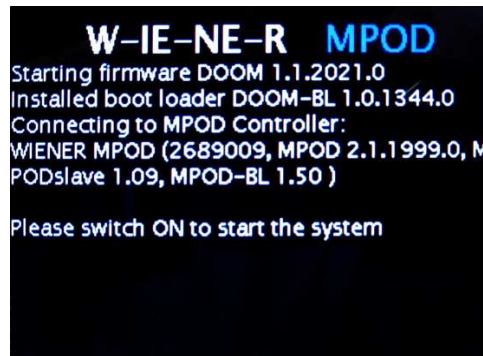

Switching on (green ON/OFF) will power up the MPOD crate and the display will

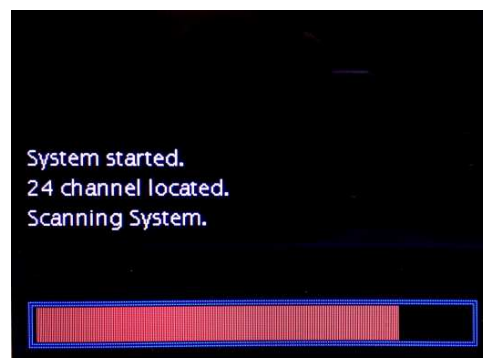
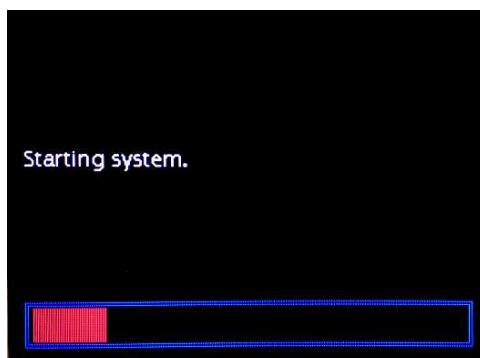

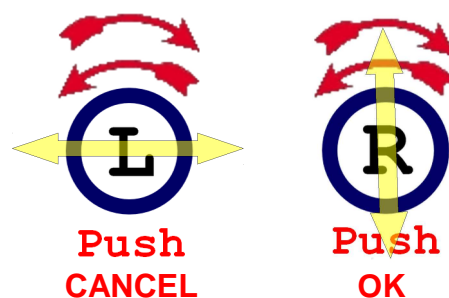

scan the crate for available module.

The two rotary knobs can be rotated and pushed. The right one controls vertical selections (e.g. to scroll down a menu task or increase/decrease a operating value), while the left one controls the horizontal selections (e.g. select other menus or sub-menus). By pushing the right knob (OK) it is possible to select a menu item or to confirm input. By pushing the left knob (CANCEL) it is possible to escape from input fields.

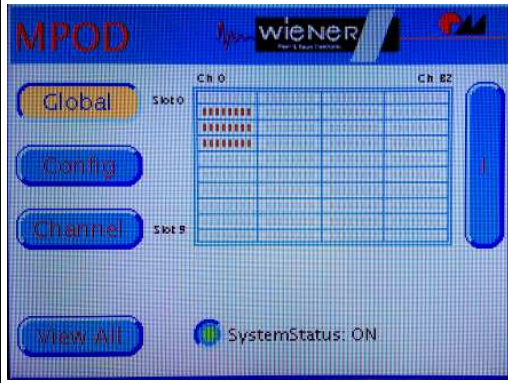
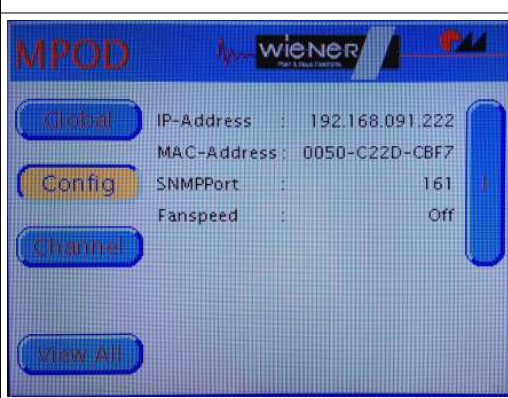

All selected menu-items are colored in yellow, data to be changed are shown in red color.

### 5.3 MPOD Display Main menu

	<p><b>GLOBAL Window</b></p> <ul style="list-style-type: none"> <li>• Rotate &lt;R&gt; to change between <b>GLOBAL, CONFIG, CHANNEL</b> and <b>VIEW ALL</b></li> </ul>
	<p><b>CONFIG Window</b></p> <ul style="list-style-type: none"> <li>• Press &lt;R&gt; or turn &lt;L&gt; to the right to enter menu to change network settings and fan speed</li> <li>• Rotate &lt;R&gt; to change between <b>GLOBAL, CONFIG, CHANNEL</b> and <b>VIEW ALL</b></li> </ul>
	<p><b>Channel Window</b></p> <ul style="list-style-type: none"> <li>• Press &lt;R&gt; or turn &lt;L&gt; to the right to enter menu to access power supply channels</li> <li>• Rotate &lt;R&gt; to change between <b>GLOBAL, CONFIG, CHANNEL</b> and <b>VIEW ALL</b></li> </ul>
	<p><b>VIEW ALL Window</b></p> <ul style="list-style-type: none"> <li>• Press &lt;R&gt; or turn &lt;L&gt; to the right to go into screen saver mode with high visibility channel display</li> <li>• Rotate &lt;R&gt; to change between <b>GLOBAL, CONFIG, CHANNEL</b> and <b>VIEW ALL</b></li> </ul>

## 5.4 MPOD Display CHANNEL menu

<p><b>Channel U100</b></p> <p><b>Switch ON</b> Status OFF</p> <p><b>Nominal</b> Sense Voltage 0.000 V</p> <p><b>Supervision</b> Terminal Voltage 0.000 V</p> <p>Current 0.000 A</p> <p>Temperature 42 C</p>	<p><b>SWITCH ON / OFF and status Window</b></p> <ul style="list-style-type: none"> <li>• Press &lt;R&gt; to switch channel ON or OFF</li> <li>• Rotate &lt;R&gt; to change between <b>SWITCH ON/OFF</b>, <b>NOMINAL</b> and <b>SUPERVISION</b></li> <li>• Rotate &lt;L&gt; to go back (left) or to select another channel (right) which will mark right button yellow, channel then can be changed with &lt;R&gt;</li> </ul>
<p><b>Channel U100</b></p> <p><b>Switch OFF</b> Status ON</p> <p><b>Nominal</b> Sense Voltage 5.061 V</p> <p><b>Supervision</b> Terminal Voltage 5.061 V</p> <p>Current 0.012 A</p> <p>Temperature 42 C</p>	
<p><b>Channel U101</b></p> <p><b>Switch OFF</b> Output Voltage 8.000 V</p> <p><b>Nominal</b> Current Limit 1.000 A</p> <p><b>Supervision</b> Voltage RampUp 100 V/s</p> <p>Voltage RampDown 100 V/s</p>	<p><b>NOMINAL settings Window</b></p> <ul style="list-style-type: none"> <li>• Press &lt;R&gt; to select parameter (will be marked yellow)</li> <li>• Rotate &lt;R&gt; to change between <b>Output Voltage</b>, <b>Current Limit</b> or <b>Voltage ramps</b></li> <li>• Press &lt;R&gt; to edit value (will be shown in red), change value with &lt;R&gt;, &lt;L&gt; will change resolution digits (red) to allow precise settings</li> <li>• <b>Press &lt;R&gt; save new values or &lt;L&gt; to discard (cancel)</b></li> <li>• Rotate &lt;L&gt; to go back (left) or to select another channel (right) which will mark right button yellow, channel then can be changed with &lt;R&gt;</li> </ul>
<p><b>Channel U100</b></p> <p><b>Switch OFF</b> Output Voltage 5.061 V</p> <p><b>Nominal</b> Current Limit 0.810 A</p> <p><b>Supervision</b> Voltage RampUp 100 V/s</p> <p>Voltage RampDown 100 V/s</p>	



### Supervision settings Window (only MPV8xxx)

- Press **<R>** to select parameter (will be marked yellow)
- Rotate **<R>** to change between parameters
- Press **<R>** to edit value (will be shown in red), change value with **<R>**, **<L>** will change resolution digits (red) to allow precise settings
- Press **<R>** save new values or **<L>** to discard (escape)
- Rotate **<L>** to go back (left) or to select another channel (right) which will mark right button yellow, channel then can be changed with **<R>**



## 6 Remote Control / Software

Please check the download section at [www.wiener-d.com](http://www.wiener-d.com) for the latest version of Mpod software and documentation!

### 6.1 Software Setup for Microsoft Windows

Before the Mpod Controller can be used, it may have to be configured according to the network environment. The factory default configuration is DHCP.

This is done locally via display or by running the MUSEcontrol utility, which allows access via the USB-port of the Mpod Controller with a computer running 32-bit Windows XP, VISTA or Windows 7.

Please download the latest version from the download area at [www.wiener-d.com](http://www.wiener-d.com). Run the MUSEControl.msi Program to install all drivers and the USB program itself. It is recommended to define a short path for the driver location during installation. Connecting the MPOD Controller via USB it should be automatically detected and the Silicon Labs USB drivers (SiLib.sys and SiUSBXp.sys) loaded



Starting the program, the main window gives a quick overview of the MPOD and its connected MPV low voltage modules. Please note that the MPOD crate has to be switched on in order to show the low voltage modules!

File	Switch...	SelectOutput	DVM	OutputConfiguration	OutputCalibration	System	Stop	Help
U4	Usense:	3.000V	I: -0.005A	Umodule:	3.165V	Status: ON		
U5	Usense:	3.999V	I: -0.004A	Umodule:	4.219V	Status: ON		
U6	Usense:	5.001V	I: 0.009A	Umodule:	5.274V	Status: ON		
U7	Usense:	5.999V	I: -0.006A	Umodule:	6.330V	Status: ON		

In case no low voltage modules are located in the crate an error message “No module found” will pop up which should be ignored. Note, all ISEG high voltage modules will not be shown and can not be controlled via USB!

To prepare the MPOD controller select System → Configuration which starts the network configuration dialog as shown below. Here you enter the TCP/IP network settings (IP address, subnet mask and default gateway). You have to use the parameters of your local network here. Please contact your network administrator for details. In order to use DHCP (factory default) an I address of 0.0.0.0 has to be selected.

IP address of 0.0.0.0 will enable DHCP.

HTTP and SNMP port numbers should only be modified if you know what you do. Setting any ports to 0 disables the server.

The “First LV Slot” item is an intermediate solution to define the slot number of the first LV-module. Any HV-module plugged into this slot will not be detected. (This setting is necessary only for older MPOD firmware versions and older MPV modules without automatic detection of their slot numbers)

Another essential menu item is the System → FirmwareUpdate which starts the firmware update procedures (see appendix A).

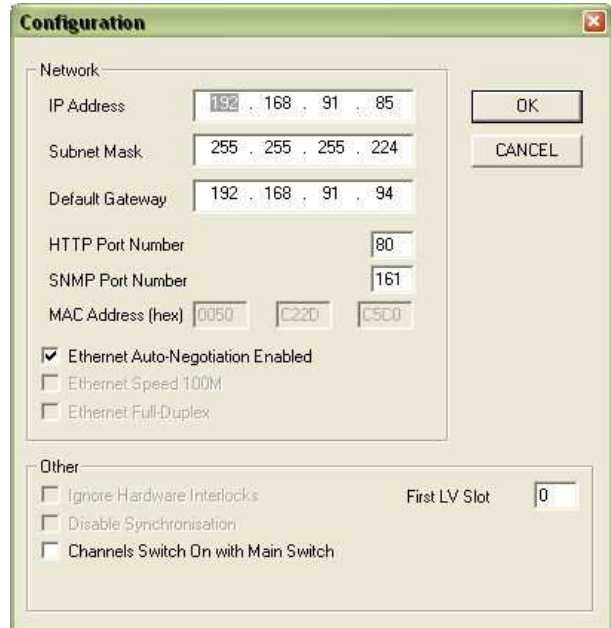

Low Voltage channels can be completely programmed and monitor within the MUSE application. You can switch on or off any channel by clicking at the line of the channel. If you click with the right mouse button, the “OutputConfiguration” dialog is entered:

The dialog is divided into five main sections:

- **Measurement**

Shows the actual measured sense voltage, terminal voltage (at the module terminals), current, the calculated power and the most critical module temperature.

- **Control & Status**

Here the channel can be switched on and off. If the channel has switched off because of any failure, the reason is displayed here, too.

- **Nominal Values**

Here the nominal output voltage (sense voltage), current limit and ramping speeds are entered. The “No Ramp at Switch Off” check box forces immediate switch off. The regulation mode can be optimized for different cable lengths (slow regulation requests both check boxes to be checked!)

- **Supervision**

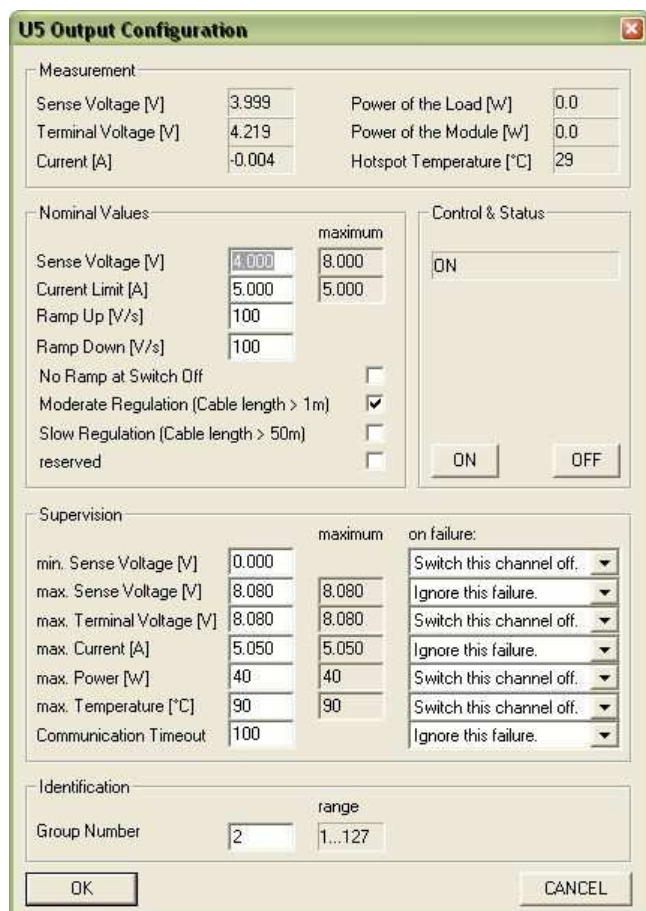

Here the threshold values of the minimum sense voltage, the maximum sense voltage, the maximum terminal voltage, the maximum current, the maximum power, the maximum temperature and the communication timeout can be entered. The right column “maximum” can only be changed by this utility and is the maximum allowed value of the left column. The left column may be changed here or via the TCP/IP network.

The most right column “on failure” defines the action if the associated threshold is exceeded.

The “communication timeout” at the last low is an internal timeout of the communication between different processors. If the processor responsible for a specific output has no data from it's master processor for longer than this time (in milliseconds), the output channel will be switched off.

- **Identification**

Here the group number of this channel can be entered.

Other main menu items associated with this dialog are “Start/Stop” (stop and restart the communication with the Mpod controller via USB) and “SelectOutput”, which simple increments the channel number which is displayed by the other dialogs.

The other main menu items are used for test and maintenance and should not used by the customer.

## **6.2 Web Browser**

With a web browser pointing to the IP address as URL it is possible to get an overview of all channels in a simple way.

Global Status

Mainframe Status	ON
------------------	----

Output Channels

Channel	Voltage	Current	Measured Sense Voltage	Measured Current	Measured Terminal Voltage	Status
U 4	3000.0 mV	5000.0 mA	2999.5 mV	-5127.0 uA	3164.6 mV	ON
U 5	4000.0 mV	5000.0 mA	3999.0 mV	-3906.3 uA	4218.8 mV	ON
U 6	5000.0 mV	5000.0 mA	5001.5 mV	8.545 mA	5273.9 mV	ON
U 7	6000.0 mV	5000.0 mA	5999.0 mV	-5371.1 uA	6330.1 mV	ON
U500	101.00 V	6000.0 uA	100.98 V	0 A	100.98 V	ON
U501	152.00 V	6000.0 uA	151.99 V	0 A	151.99 V	ON
U502	103.00 V	6000.0 uA	103.05 V	0.0 uA	103.05 V	ON
U503	154.00 V	6000.0 uA	154.03 V	0 A	154.03 V	ON
U504	105.00 V	6000.0 uA	104.61 V	0 A	104.61 V	ON
U505	156.00 V	6000.0 uA	155.78 V	0.1 uA	155.78 V	ON
U506	107.00 V	6000.0 uA	106.97 V	0 A	106.97 V	ON
U507	152.00 V	6000.0 uA	152.14 V	0 A	152.14 V	ON
U508	0 V	6000.0 uA	0 V	0 A	0 V	OFF
U509	0 V	6000.0 uA	0 V	0 A	0 V	OFF
U510	0 V	6000.0 uA	0 V	0 A	0 V	OFF
U511	0 V	6000.0 uA	0 V	0 A	0 V	OFF
U512	0 V	6000.0 uA	193.20 mV	0 A	193.20 mV	OFF
U513	0 V	6000.0 uA	0 V	0 A	0 V	OFF
U514	0 V	6000.0 uA	0 V	0 A	0 V	OFF
U515	0 V	6000.0 uA	0 V	0 A	0 V	OFF

### 6.3 NetSNMP

NetSNMP is an open source SNMP program which can be used to access the Mpod controller via the **Simple Network Management Protocol**. Please see <http://net-snmp.sourceforge.net/> for more details.

Please install netSNMP from the CD-ROM or downloaded from WIENER support web site on the control computer. In order to perform SNMP calls from any WIENER product the WIENER-CRATE-MIB file must be stored somewhere on the PC doing the calls, by default that location should be /usr/share/snmp/mibs (Windows: C:\usr\share\snmp\mibs).

The most commonly used net-snmp calls are:

**snmpwalk** – returns groups of parameters / items

**snmpget** – returns a specific parameter (read)

**snmpset** – sets a specific parameter (write)

Please see the Net-snmp description and help files for detailed instructions and options. All parameters defined for the WIENER Mpod system as well as crates and other power supplies are contained within the WIENER-CRATE-MIB.txt file.

The following community groups are used:

“**public**”: for all read operations

“**private**”: to switch crate on or off  
“**admin**”: to change parameters as fan speed or temperature limits  
“**guru**”: to change HV and LV channel parameters as voltages, current limits, ramps, ...

A fast and easy way to begin using SNMP is to use command line arguments. The command line arguments specified in this document are based on netSNMP. The command line syntax is the same for both windows and Linux (and probably MAC OSX).

For all WIENER-CRATE-MIB library calls a quick help text can be shown by using

**snmptranslate -On -Td WIENER-CRATE-MIB::xxxx**

**snmptranslate -On -Td WIENER-CRATE-MIB::outputName**

.1.3.6.1.4.1.19947.1.3.2.1.2

outputName OBJECT-TYPE

-- FROM WIENER-CRATE-MIB

-- TEXTUAL CONVENTION DisplayString

SYNTAX OCTET STRING (1..4)

DISPLAY-HINT "255a"

MAX-ACCESS read-only

STATUS current

DESCRIPTION "A textual string containing a short name of the output. If the crate is equipped with an alphanumeric display, this string is shown to identify a output channel."

::= { iso(1) org(3) dod(6) internet(1) private(4) enterprises(1) wiener(19947) c rate(1) output(3) outputTable(2) outputEntry(1) 2 }

A first communication with the Mpod crate can be done using the snmpwalk to confirm the existence of the power supply at the given IP address.

**snmpwalk -Cp -Oqv -v 2c -M \$path -m +WIENER-CRATE-MIB -c public \$ip**

with:

**snmpwalk:** This command will retrieve a block of information.

**-v 2c:** This parameters specifies which version of the SNMP to use. WIENER devices use SNMP 2C.

**-M \$path:** This parameter should be replaced with the path to the WIENER-CRATE-MIB.txt file. It is not needed in case the default path is used.

**-m +WIENER-CRATE-MIB:** This parameter tells the command to look at the WIENER-CRATE-MIB to resolve the OID name.

**-c public:** This specifies which community of values can be accessed.

**\$ip:** This should be replaced with the IP address of the MPOD crate.

Example for crate with IP address 192.168.2.25:

*snmpwalk -v 2c -m +WIENER-CRATE-MIB -c public 192.168.2.25*

returns:

*SNMPv2-MIB::sysDescr.0 = STRING: WIENER MPOD (4193086, MPOD  
1.1.1.6,  
MPODslave 1.06)  
SNMPv2-MIB::sysObjectID.0 = OID: WIENER-CRATE-MIB::sysMainSwitch.0  
SNMPv2-MIB::sysUpTime.0 = Timeticks: (13401) 0:02:14.01  
SNMPv2-MIB::sysContact.0 = STRING:  
SNMPv2-MIB::sysName.0 = STRING:  
SNMPv2-MIB::sysLocation.0 = STRING:  
SNMPv2-MIB::sysServices.0 = INTEGER: 79*

A list of all available parameters or sub-parameters as for instance channels can be obtained using the command `snmpwalk` with the parameter "crate". To get all parameters use:

**`snmpwalk -Cp -Oqv -v 2c -M $path -m +WIENER-CRATE-MIB -c public $ip  
crate`**

example:

*snmpwalk -v 2c -m +WIENER-CRATE-MIB -c public 192.168.2.25 crate*

Further it is possible obtain the array of names or values for a specific parameter. The following command provides a list of all existing output channels:

**`snmpwalk -Cp -Oqv -v 2c -M $path -m +WIENER-CRATE-MIB -c public $ip  
outputName`**

Example:

*snmpwalk -v 2c -m +WIENER-CRATE-MIB -c public 192.168.2.25 outputName*

returns for MPOD system with 2 ISEG EHS HV modules (8 channels each) in slot 2 and 3:

*WIENER-CRATE-MIB::outputName.u100 = STRING: U100  
WIENER-CRATE-MIB::outputName.u101 = STRING: U101  
WIENER-CRATE-MIB::outputName.u102 = STRING: U102  
WIENER-CRATE-MIB::outputName.u103 = STRING: U103  
WIENER-CRATE-MIB::outputName.u104 = STRING: U104  
WIENER-CRATE-MIB::outputName.u105 = STRING: U105  
WIENER-CRATE-MIB::outputName.u106 = STRING: U106  
WIENER-CRATE-MIB::outputName.u107 = STRING: U107  
WIENER-CRATE-MIB::outputName.u200 = STRING: U200  
WIENER-CRATE-MIB::outputName.u201 = STRING: U201  
WIENER-CRATE-MIB::outputName.u202 = STRING: U202  
WIENER-CRATE-MIB::outputName.u203 = STRING: U203  
WIENER-CRATE-MIB::outputName.u204 = STRING: U204  
WIENER-CRATE-MIB::outputName.u205 = STRING: U205  
WIENER-CRATE-MIB::outputName.u206 = STRING: U206  
WIENER-CRATE-MIB::outputName.u207 = STRING: U207*

This example returns 16 index numbers. Please note the following geographic module and channel number coding for the SNMP call indexes, where the first digit is defined by the slot number and the following two by the channel of the particular module in this slot:

Slot	Channel	Name	index
1	0 to 99	Uxx	.u00 to .u99
2	0 to 99	U1xx	.u100 to .u199
...	...	...	...
10	0 to 99	U9xx	.u901 to .u999

Please note that both the index as well as the name can be used!

```
snmpget -v 2c -m +WIENER-CRATE-MIB -c public 192.168.0.80 outputVoltage.u0  
WIENER-CRATE-MIB::outputVoltage.u0 = Opaque: Float: 123.000000 V
```

is identical to

```
snmpget -v 2c -m +WIENER-CRATE-MIB -c public 192.168.0.80 outputVoltage.1  
WIENER-CRATE-MIB::outputVoltage.u0 = Opaque: Float: 123.000000 V
```

In case of multi crate system there will be an additional digit for the crate number:

Name = 1000 \* crate + 100\*slot + channel  
index = 1000 \* crate + 100\*slot + channel

(crate: 0 .... 9, slot: 0 ... 9 , channel: 0 ... 99)

To see all Output channel set voltage values use snmpwalk with outputVoltage:

```
snmpwalk -Cp -Oqv -v 2c -M $path -m +WIENER-CRATE-MIB -c public $ip  
outputVoltage
```

Example:

```
snmpwalk -v 2c -m +WIENER-CRATE-MIB -c public 192.168.2.25 outputVoltage
```

returns for a MPOD system with one 8 channel ISEG EHS HV module in slot 3:

```
WIENER-CRATE-MIB::outputVoltage.u200 = Opaque: Float: 0.000000 V  
WIENER-CRATE-MIB::outputVoltage.u201 = Opaque: Float: 0.000000 V  
WIENER-CRATE-MIB::outputVoltage.u202 = Opaque: Float: 0.000000 V  
WIENER-CRATE-MIB::outputVoltage.u203 = Opaque: Float: 0.000000 V  
WIENER-CRATE-MIB::outputVoltage.u204 = Opaque: Float: 0.000000 V  
WIENER-CRATE-MIB::outputVoltage.u205 = Opaque: Float: 0.000000 V  
WIENER-CRATE-MIB::outputVoltage.u206 = Opaque: Float: 0.000000 V  
WIENER-CRATE-MIB::outputVoltage.u207 = Opaque: Float: 0.000000 V
```

After obtaining information about the power supplies or a list of channels and parameters, it is useful to be able to write or read information about it. This can be done using the **snmpget** and **snmpset** commands.

```
snmpget -Oqv -v 2c -M $path -m +WIENER-CRATE-MIB -c guru $ip  
name.index
```

```
snmpset -v 2c -M $path -m +WIENER-CRATE-MIB -c guru $ip name.index  
format value
```

The most common kind of call you will want is to get data from the power supply. This is easily done via the **snmpget** command. The example below retrieves information about whether the main power for the crate is on. If you wish to test this example on your own system replace "\$path" with the path to WIENER-CRATE-

MIB.txt (/usr/share/snmp/mibs by default and "\$ip" with the ip address of your MPOD (see following examples).

```
snmpget -v 2c -M $path -m +WIENER-CRATE-MIB -c public $ip sysMainSwitch.0  
WIENER-CRATE-MIB::sysMainSwitch.0 = INTEGER: OFF(0)
```

This indicates that the MPOD crate is currently off. To better understand the call above we will break it down by parameter:

**snmpget:** This command will retrieve a value about the MPOD crate or one of the channels it houses..

**-v 2c:** This parameters specifies which version of the SNMP to use. WIENER devices use SNMP 2C.

**-M \$path:** This parameter should be replaced with the path to the WIENER-CRATE-MIB.txt file.

**-m +WIENER-CRATE-MIB:** This parameter tells the command to look at the WIENER-CRATE-MIB to resolve the OID name.

**-c public:** This specifies which community of values can be accessed.

**\$ip:** This should be replaced with the IP address of the MPOD crate.

**sysMainSwitch.0:**

This is the register you wish to retrieve.

Since we we know from the call above that the crate is off, we may want to turn it on. (Software power cycling is only possible of the green mains switch on the MPOD is "ON", this is to prevent a remote user to override a local user and adds a level of safety to the unit.) To turn MPOD on, we can use the command:

```
snmpset -v 2c - path -m +WIENER-CRATE-MIB -c private $ip sysMainSwitch.0 i 1
```

Most of the parameters for snmpset are the same as snmpget, the new parameters are highlighted below.

**i:** Since sysMainSwitch.0 is an integer value, we specify the value to be an integer with.

**1:** This is the value we wish to write. In this case we write 'one' to set the main switch to on.

For most of the write commands (snmpset) the access type has to be changed from public to guru.

A complete list of value names that can be written or read via SNMP can be found in the WIENER-CRATE-MIB but commonly needed values are:

Value Name	Type	Access	Comments
<b>outputVoltage</b>	Float	R/W	The Channel set Voltage
<b>outputCurrent</b>	Float	R/W	The channel current limit
<b>outputMeasurementSenseVoltage</b>	Float	R	Actual channel Voltage



<b>outputMeasurementCurrent</b>	Float	R	Actual channel current
<b>outputSwitch</b>	Integer	R/W	Turns channel ON / OFF, emergency off, reset error flags
<b>outputVoltageRiseRate</b>	Float	R/W	Channel ramp rate
<b>outputStatus</b>	Bits	R	Channel Status information

For example, to read channel set voltage use:

**snmpget -Oqv -v 2c -M \$path -m +WIENER-CRATE-MIB -c guru \$ip outputVoltage.index**

Example:

```
snmpget -v 2c -m +WIENER-CRATE-MIB -c public 192.168.2.25 outputVoltage.u0
WIENER-CRATE-MIB::outputVoltage.u0 = Opaque: Float: 0.000000 V
```

Write and read individual set voltages, “guru” access needed to write!

```
snmpset -v 2c -m +WIENER-CRATE-MIB -c guru 192.168.2.25 outputVoltage.u101 F 200
WIENER-CRATE-MIB::outputVoltage.u101 = Opaque: Float: 200.000000 V
```

Note the “F” before the 200, this indicates that the value is a floating point number. This value can be read back via:

```
snmpget -v 2c -m +WIENER-CRATE-MIB -c public 192.168.2.25 outputVoltage.u101
WIENER-CRATE-MIB::outputVoltage.u101 = Opaque: Float: 200.000000 V
```

Turning Channels ON/OFF - The individual channels of an MPOD system low or high voltage module can be turned on or off using the snmpset command. To turn on channel Ux:

**snmpset -Oqv -v 2c -M \$path -m +WIENER-CRATE-MIB -c guru \$ip outputSwitch.index i 1**

The same channel can be turned off with:

**snmpset -Oqv -v 2c -M \$path -m +WIENER-CRATE-MIB -c guru \$ip outputSwitch.index i 0**

Example:

```
snmpset -v 2c -m +WIENER-CRATE-MIB -c guru 192.168.2.25 outputSwitch.u101 i 1
```

The outputSwitch can also be used for emergency-off and to reset error flags. The matching values are: { off(0), on(1), resetEmergencyOff(2), setEmergencyOff(3), clearEvents(10) }

MPOD low and high voltage modules have programmable voltage ramp speeds. The WIENER low voltage modules allow different ramp up and down values for each channel whereas for ISEG modules with common ramp the channel-ID can be any channel of the module! For write access “guru” is needed:

**snmpset -Oqv -v 2c -M \$path -m +WIENER-CRATE-MIB -c guru \$ip**

## outputVoltageRiseRate.index F value

Example:

```
snmpset -v 2c -m +WIENER-CRATE-MIB -c guru 192.168.2.25
```

```
outputVoltageRiseRate.u101 F 10
```

```
WIENER-CRATE-MIB::outputVoltageRiseRate.u101 = Opaque: Float: 10.000000 V/s
```

```
snmpget -v 2c -m +WIENER-CRATE-MIB -c public 192.168.2.25
```

```
outputVoltageRiseRate.u101
```

```
WIENER-CRATE-MIB::outputVoltageRiseRate.u101 = Opaque: Float: 10.000000 V/s
```

To access multiple units the groupsSwitch function provides access to all modules in the MPOD crate (index 0), all ISEG HV modules (index 64), or to all WIENER low voltage modules (index 128). In addition groups can be defined for low voltage modules.

Item	Type	Access	Switch functions
groupsSwitch	integer	write	Off (0), On (1), resetEmergencyOff (2), setEmergencyOff (3), disableKill (4), enableKill (5), clearEvents (10)

Examples:

switch all channels of all modules on:

```
snmpset -v 2c -m +WIENER-CRATE-MIB -c guru 192.168.0.80 groupsSwitch.0 i 1
```

```
WIENER-CRATE-MIB::groupsSwitch.0 = INTEGER: on(1)
```

switch all channels off:

```
snmpset -v 2c -m +WIENER-CRATE-MIB -c guru 192.168.0.80 groupsSwitch.0 i 0
```

```
WIENER-CRATE-MIB::groupsSwitch.0 = INTEGER: off(0)
```

switch all high voltage channels (ISEG modules) off:

```
snmpset -v 2c -m +WIENER-CRATE-MIB -c guru 192.168.0.80 groupsSwitch.64 i 0
```

```
WIENER-CRATE-MIB::groupsSwitch.64 = INTEGER: off(0)
```

RESET ISEG HV Modules after Safetyloop error:

```
snmpset -v 2c -m +WIENER-CRATE-MIB -c guru 192.168.0.80 groupsSwitch.64 i 10
```

```
WIENER-CRATE-MIB::groupsSwitch.64 = INTEGER: clearEvents(10)
```

## 6.4 ISEG High voltage module special commands

Item	Type	Access	Unit	Range
outputVoltageRiseRate	float value	read-write	[V/s]	2V/s - 20% Vnom 1% (KILL enabled)

ISEG high voltage modules have one common value for ramping up and down for all channels. This value can be set or read by using any channel number of the particular module as index. For ISEG high voltage modules with 2 PCB's each of the sub-groups of one PCB may have one ramp value. In this case one should set the ramp twice by using a low and high channel number. ISEG EHQ, EHS, EDS and EBS modules typically have a ramp rate range from 1V/s .... 20% of Vnom (max. nominal voltage). In case KILL is enabled the maximum ramp rate is reduced

to 1% in order to lower the risk of unwanted trips during voltage ramp cycles.

**snmpset -Oqv -v 2c -M \$path -m +WIENER-CRATE-MIB -c guru \$ip  
outputVoltageRiseRate.index F value**

Item	Type	Access	Unit	Range
outputCurrentRiseRate	float value	read-write	[A/s]	2 - 100% nom. Val.
outputCurrentFallRate	float value	read-write	[A/s]	2 - 100% nom. Val.
outputTripTimeMaxCurrent	integer	read-write	[ms]	16 – 4000 ms

#### DESCRIPTION

The outputTripTimeMaxCurrent defines a span for the time out function. The activity is depending from the programmed bit field outputFailureMaxCurrent of the item outputSupervisionBehavior. A write value of **0** is switching off the delayed trip function which was defined in the bit field outputFailureMaxCurrent of outputSupervisionBehavior before.

Item	Type	Access	Status bits / Switch functions
outputStatus	bits	read	outputEnableKill (13) outputEmergencyOff (14)
outputSwitch	integer	read-write	Off (0), On (1), resetEmergencyOff (2), setEmergencyOff (3), clearEvents (10)

#### DESCRIPTION

Read: An enumerated value which shows the current state of the output channel.

Write: Change the state of the channel.

If the channel is On, and the write value is Off, then the channel will switch off. If the channel is Off, and the write value is On, and if no other signals (mainInhibit, outputInhibit, outputEmergencyOff or outputFailureMaxCurrent) are active, then the channel will switch on.

If the write value is resetEmergencyOff, then the channel will leave the state EmergencyOff.

A write of clearEvents is necessary before the voltage can ramp up again. If the write value is setEmergencyOff, then the channel will have the state EmergencyOff, which means that the High Voltage will switch off without a ramp and reset of the outputVoltage to null volt.

If the write value is clearEvents, then all failure messages of the outputStatus will be reset (all channel events, all module events and the state EmergencyOff).

Item	Type	Access	Switch functions
groupsSwitch.64	integer	write	Off (0), On (1), resetEmergencyOff (2), setEmergencyOff (3), disableKill (4), enableKill (5), clearEvents (10)

#### DESCRIPTION

Read: This function is not defined with groups of output channels.  
Write: Switch the state of all channels of group 64 (all high voltage modules).

If any channel is On, and the write value is Off, then all channels will switch off.  
If any channel is Off, and the write value is On, and if no other signals (mainInhibit, outputInhibit, outputEmergencyOff or outputFailureMaxCurrent) are active, then all channels will switch on.

If the write value is resetEmergencyOff, then all channels will leave the state EmergencyOff.

A write of clearEvents is necessary before the voltage can ramp up again.  
If the write value is setEmergencyOff, then all channels will have the state EmergencyOff, which means that the High Voltage will switch off without a ramp and reset of the outputVoltage to null volt.

If the write value is disableKill, then all channels will switch to disableKill.  
If the write value is enableKill, then all channels will switch to enableKill.  
If the write value is clearEvents, then all failure messages of the outputStatus will be reset (all channel events, all module events and the state EmergencyOff).

Item	Type	Access
outputSupervisionBehavior	integer	read-write

#### DESCRIPTION

A bit field packed into an integer which define the behaviour of the output channel / power supply after failures.

For each supervision value, a two-bit field exists. The enumeration of this value ( $..L+..H*2$ ) is:

WIENER LV devices

0 ignore the failure

1 switch off this channel

2 switch off all channels with the same group number

3 switch off the complete crate.

iseg HV devices

0 ignore the failure

1 switch off this channel by ramp down the voltage

2 switch off this channel by set a internal EmergencyOff

3 switch off the whole board of the HV module by set EmergencyOff.

The position of the bit fields in the integer value are:

Bit 0, 1: outputFailureMinSenseVoltage

Bit 2, 3: outputFailureMaxSenseVoltage

Bit 4, 5: outputFailureMaxTerminalVoltage

Bit 6, 7: outputFailureMaxCurrent

Bit 8, 9: outputFailureMaxTemperature

Bit 10, 11: outputFailureMaxPower

Bit 12, 13: outputFailureInhibit

Bit 14, 15: outputFailureTimeout

The iseg HV devices can use the bit fields:

outputFailureMaxCurrent support of the function delayed trip

The programmed activity will start when the

value actual current exceeded permanently the  
of the item outputCurrent over the span of the  
programmed time out (set via the item  
outputTripTimeMaxCurrent).

outputFailureInhibit support of the optional hardware function  
EXTERNAL INHIBIT per channel  
The programmed activity will start when an  
external channel inhibit occurs

The channel state have to be in disableKill for a proper work of the  
configuration of the behaviour for the functions above.

Settings for outputSupervisionBehavior:

Action	outputFailureMaxCurrent	outputFailureInhibit
ignore the failure	0	0
switch off this channel by ramp down the voltage	64	4096
switch off this channel by set a internal EmergencyOff	128	8192
switch off the whole board of the HV module by set EmergencyOff	192	12288

Attention!!! In order to use delayed software trips please make sure to have a firmware  
on the ISEG high voltage modules which supports this feature. Please see the following  
table of supported firmware releases. In case of older firmware the software trip will  
not act, i.e. the error will be detected but no action (ram down of channel) will happen.

Name of firmware	Release	Date	Description	Device class
E16D0	4.25	05/08/09	EDS 16/32 channel distributor module, with $V_{max}$ from $V_{O_{max}}$ to $(V_{O_{max}} - 1kV)$	1
E16D1	4.25	05/08/09	EDS 16/32 distributor module	21
E08C0	2.22	02/23/09	EHS 4/8/16 channel, common GND module	24
E08F0	2.27	12/18/08	EHS 4/8/16 channel, floating GND module	25
E08F2	4.06	06/23/09	EHS 4/8/16 channel, floating GND module, 2 ranges for measurement of current	26
E08B0	1.02	07/10/09	EBS 8/16 bipolar channels, distributor module	28

Example of necessary SNMP commands for the delayed trip function:  
snmpset -Oqv -v 2c -m +WIENER-CRATE-MIB -c guru 192.168.2.25  
groupsSwitch.64 i 4  
disableKill

```

snmpset -Oqv -v 2c -m +WIENER-CRATE-MIB -c guru 192.168.2.25
outputVoltage.u100 F 60
60.000000 V
snmpset -Oqv -v 2c -m +WIENER-CRATE-MIB -c guru 192.168.2.25
outputSwitch.u100 i 1
On
snmpget -Oqv -v 2c -m +WIENER-CRATE-MIB -c public 192.168.2.25
outputVoltage.u100
60.000000 V
snmpget -Oqv -v 2c -m +WIENER-CRATE-MIB -c public 192.168.2.25
outputMeasurementSenseVoltage.u100
60.104588 V
snmpget -Oqv -v 2c -m +WIENER-CRATE-MIB -c public 192.168.2.25
outputMeasurementCurrent.u100
0.000001 A
snmpgetx -Oqv -v 2c -m +WIENER-CRATE-MIB -c public 192.168.2.25
outputMeasurementCurrent.u100
0.000000735 A
snmpget -Oqv -v 2c -m +WIENER-CRATE-MIB -c public 192.168.2.25
outputSupervisionBehavior.u100
0
snmpset -Oqv -v 2c -m +WIENER-CRATE-MIB -c guru 192.168.2.25
outputSupervisionBehavior.u100 i 64
64
snmpget -Oqv -v 2c -m +WIENER-CRATE-MIB -c public 192.168.2.25
outputSupervisionBehavior.u100
64
snmpget -Oqv -v 2c -m +WIENER-CRATE-MIB -c public 192.168.2.25
outputTripTimeMaxCurrent.u100
0 ms
snmpset -Oqv -v 2c -m +WIENER-CRATE-MIB -c guru 192.168.2.25
outputTripTimeMaxCurrent.u100 i 3000
3000 ms /* delay of 3 sconds */
snmpget -Oqv -v 2c -m +WIENER-CRATE-MIB -c public 192.168.2.25
outputStatus.u100
"80 " /* outputOn */
snmpgetx -Oqv -v 2c -m +WIENER-CRATE-MIB -c public 192.168.2.25
outputMeasurementCurrent.u100
0.000000735 A
snmpsetx -Oqv -v 2c -m +WIENER-CRATE-MIB -c guru 192.168.2.25
outputCurrent.u100 F 0.0000007
0.000000700 A
snmpget -Oqv -v 2c -m +WIENER-CRATE-MIB -c public 192.168.2.25
outputStatus.u100
"04 08 " /*outputFailureMaxCurrent, outputRampDown */
snmpget -Oqv -v 2c -m +WIENER-CRATE-MIB -c public 192.168.2.25
outputStatus.u100
"04 " /* outputFailureMaxCurrent */
snmpset -Oqv -v 2c -m +WIENER-CRATE-MIB -c guru 192.168.2.25
outputSwitch.u100 i 10
clearEvents
snmpsetx -Oqv -v 2c -m +WIENER-CRATE-MIB -c guru 192.168.2.25
outputCurrent.u100 F 0.00001

```

```

0.000010000 A
snmpset -Oqv -v 2c -m +WIENER-CRATE-MIB -c guru 192.168.2.25
outputSwitch.u100 i 1
On
snmpget -Oqv -v 2c -m +WIENER-CRATE-MIB -c public 192.168.2.25
outputStatus.u100
"80 10 " /* outputOn, outputRampUp */
/* a load has been switched on channel 0 to bring them in state CC current
limited */
snmpget -Oqv -v 2c -m +WIENER-CRATE-MIB -c public 192.168.2.25
outputStatus.u100
"80 20 " /* outputOn, outputCurrentLimited */
.
snmpget -Oqv -v 2c -m +WIENER-CRATE-MIB -c public 192.168.2.25
outputStatus.u100
"80 20 " /* outputOn, outputCurrentLimited */
/* the delayed trip fuction ramps the voltage after 3 seconds to zero */
snmpget -Oqv -v 2c -m +WIENER-CRATE-MIB -c public 192.168.2.25
outputStatus.u100
"04 08 " /* outputFailureMaxCurrent, outputRampDown */

```

## 6.5 Change of community names / setting of passwords

For the communication with MPOD modules 4 types of SNMP communities are used, "public", "private", "admin" and "guru". By default the community names are equal to the community types.

```
snmpwalk -v 2c -m +WIENER-CRATE-MIB -c guru 192.168.0.80
```

```
snmpCommunityName
```

```
WIENER-CRATE-MIB::snmpCommunityName.public = STRING: "public"
```

```
WIENER-CRATE-MIB::snmpCommunityName.private = STRING: "private"
```

```
WIENER-CRATE-MIB::snmpCommunityName.admin = STRING: "admin"
```

```
WIENER-CRATE-MIB::snmpCommunityName.guru = STRING: "guru"
```

```
snmpwalk -v 2c -m +WIENER-CRATE-MIB -c private 192.168.0.80
```

```
snmpCommunityName
```

```
WIENER-CRATE-MIB::snmpCommunityName.public = STRING: "public"
```

```
WIENER-CRATE-MIB::snmpCommunityName.private = STRING: "private"
```

In order to secure the MPOD system communication the community names can be used as passwords and be changed accordingly. The following example shows how the change and test the community names. Using a wrong community name will result in a time out error. Please note, that especially the communities with write access (private, admin, guru) should be protected.

```
snmpset -v 2c -m +WIENER-CRATE-MIB -c guru 192.168.0.80
```

```
snmpCommunityName.guru s seCrET
```

```
WIENER-CRATE-MIB::snmpCommunityName.guru = STRING: "seCrET"
```

```
snmpwalk -v 2c -m +WIENER-CRATE-MIB -c guru 192.168.0.80
```

```
snmpCommunityName
```

```
Timeout: No Response from 192.168.0.80
```

*snmpwalk -v 2c -m +WIENER-CRATE-MIB -c seCrET 192.168.0.80*

*snmpCommunityName*

*WIENER-CRATE-MIB::snmpCommunityName.public = STRING: "public"*

*WIENER-CRATE-MIB::snmpCommunityName.private = STRING: "private"*

*WIENER-CRATE-MIB::snmpCommunityName.admin = STRING: "admin"*

*WIENER-CRATE-MIB::snmpCommunityName.guru = STRING: "seCrET"*

## 6.6 MIB Browser

There are several commercial or open source MIB-Browser programs available which can be used for SNMP communication. These provide often a simple GUI and allow SNMP calls. Following is a list of some free or open source MIB – browsers:

<http://www.ireasoning.com/mibbrowser.shtml>

[http://www.serverscheck.com/mib\\_browser/](http://www.serverscheck.com/mib_browser/)

<http://www.mibble.org/>

<http://www.ks-soft.net/hostmon.eng/mibbrowser/index.htm>

<http://www.tembria.com/products/snmpbrowser/index.html>

Name/OID	Value	Type
outputIndex.4	u3	Integer
outputIndex.5	u4	Integer
outputIndex.6	u5	Integer
outputIndex.7	u6	Integer
outputIndex.8	u7	Integer
outputIndex.9	u8	Integer
outputIndex.10	u9	Integer
outputIndex.11	u10	Integer
outputIndex.12	u11	Integer
outputIndex.13	u12	Integer
outputIndex.14	u13	Integer
outputIndex.15	u14	Integer
outputIndex.16	u15	Integer
outputName.1	U0	OctetString
outputName.2	U1	OctetString
outputName.3	U2	OctetString
outputName.4	U3	OctetString
outputName.5	U4	OctetString
outputName.6	U5	OctetString
outputName.7	U6	OctetString
outputName.8	U7	OctetString
outputName.9	U8	OctetString
outputName.10	U9	OctetString
outputName.11	U10	OctetString
outputName.12	U11	OctetString
outputName.13	U12	OctetString
outputName.14	U13	OctetString
outputName.15	U14	OctetString
outputName.16	U15	OctetString
outputGroup.1	0	Integer
outputGroup.2	0	Integer
outputGroup.3	0	Integer
outputGroup.4	0	Integer
outputGroup.5	0	Integer
outputGroup.6	0	Integer
outputGroup.7	0	Integer
outputGroup.8	0	Integer
outputGroup.9	1	Integer



## 6.7 A BASH Simple Script for SNMP

All of the commands above could be combined into scripts to set and monitor a predefined set of channels. For example a Bash script to read all channels and set the voltages and current limit to the same value for each channel could look like:

```
#!/bin/bash
# Simple Bash Script that will read and set all channels in a MPOD crate

ip=192.168.2.25
path=/usr/share/snmp/mibs
setVoltage=5
setCurrent=.100
setStatus=1
setRamp=100

channelCount=$(snmpget -Oqv -v 2c -M $path -m +WIENER-CRATE-MIB -c guru $ip
outputNumber.0)
indices=$(snmpwalk -Oqv -v 2c -M $path -m +WIENER-CRATE-MIB -c guru $ip
outputIndex)
x=(`echo $indices | tr ' '`)

COUNTER=0
while [ $COUNTER -lt $channelCount ]; do
  index=$(echo ${x[$COUNTER]})

  voltage=$(snmpset -OqvU -v 2c -M $path -m +WIENER-CRATE-MIB -c guru $ip
outputVoltage.$index F $setVoltage)
  iLimit=$(snmpset -OqvU -v 2c -M $path -m +WIENER-CRATE-MIB -c guru $ip
outputCurrent.$index F $setCurrent)
  rampspeed=$(snmpset -OqvU -v 2c -M $path -m +WIENER-CRATE-MIB -c guru $ip
outputVoltageRiseRate.$index F $setRamp)
  status=$(snmpset -OqvU -v 2c -M $path -m +WIENER-CRATE-MIB -c guru $ip
outputSwitch.$index i $setStatus)

  voltage=$(snmpget -OqvU -v 2c -M $path -m +WIENER-CRATE-MIB -c guru $ip
outputVoltage.$index)
  iLimit=$(snmpget -OqvU -v 2c -M $path -m +WIENER-CRATE-MIB -c guru $ip
outputCurrent.$index)
  sense=$(snmpget -OqvU -v 2c -M $path -m +WIENER-CRATE-MIB -c guru $ip
outputMeasurementSenseVoltage.$index)
  current=$(snmpget -OqvU -v 2c -M $path -m +WIENER-CRATE-MIB -c guru $ip
outputMeasurementCurrent.$index)
  rampspeed=$(snmpget -OqvU -v 2c -M $path -m +WIENER-CRATE-MIB -c guru $ip
outputVoltageRiseRate.$index)
  status=$(snmpget -OqvU -v 2c -M $path -m +WIENER-CRATE-MIB -c guru $ip
outputSwitch.$index)

  echo "$voltage $iLimit $sense $current $rampspeed $status"

  let COUNTER=COUNTER+1
done
```

## 6.8 Mpod SNMP Parameter List (most common)

Parameter	Multi	Access	Type
sysMainSwitch	1	R/W	i
sysStatus	1	R/W	i
sysVmeSysReset	1	R/W	i
outputNumber	1	R	i
groupsNumber	1	R	i
outputName	320	R	string
outputGroup	320	R	i
outputStatus	320	R	i
outputMeasurementSenseVoltage	320	R	F
outputMeasurementTerminalVoltage	320	R	F
outputMeasurementCurrent	320	R	F
outputMeasurementTemperature	320	R	i
outputSwitch	320	R/W	i
outputVoltage	320	R/W	F
outputCurrent	320	R/W	F
outputVoltageRiseRate	320	R/W	F
outputVoltageFallRate	320	R/W	F
outputSupervisionBehavior	320	R/W	i
outputSupervisionMinSenseVoltage	320	R/W	F
outputSupervisionMaxSenseVoltage	320	R/W	F
outputSupervisionMaxTerminalVoltage	320	R/W	F
outputSupervisionMaxCurrent	320	R/W	F
outputSupervisionMaxTemperature	320	R/W	i
outputConfigMaxSenseVoltage	320	R	F
outputConfigMaxTerminalVoltage	320	R	F
outputConfigMaxCurrent	320	R	F
outputConfigMaxPower	320	R	F
sensorNumber	1	R	i
sensorTemperature	12	R	i
sensorWarningThreshold	12	R/W	i
sensorFailureThreshold	12	R/W	i
snmpCommunityName	4	R/W	string
psFirmwareVersion	1	R	string
psSerialNumber	1	R	string
psOperatingTime	1	R	i
psDirectAccess	1	R/W	string
fanFirmwareVersion	1	R	string
fanSerialNumber	1	R	string
fanOperatingTime	1	R	i
fanAirTemperature	1	R	i
fanSwicthOffDelay	1	R/W	i
fanNominalSpeed	1	R/W	i
fanNumberOfFans	1	R	i
fanSpeed	6	R	i

(see SNMP tree structure at end of manual for full structure)

## 6.9 LabView Control Program (NETSNMP)

All LabView MPOD function VI's are using SNMP calls from the WIENER\_SNMP\_LV.DLL. This DLL requires the installation of NETSNMP and the WIENER -CRATE-MIB.txt file as described in Chapter 6.3!

The supplied LabView Mini programs allow controlling both low and high voltage channels for small configurations of up to 4 Mpod modules. The programs can run in parallel to web monitoring. The programs are provided as executable which will require the NI LV Run-time-engine. All source code is available on the CD-ROM. Please run these VI's with either LabView 8.5 or higher .

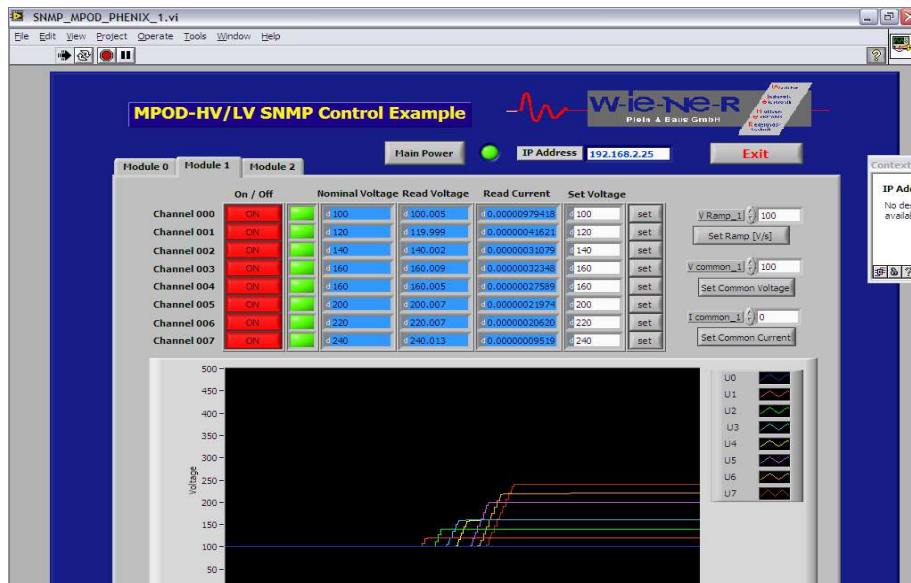

Example for LabView VI for 8 channel high voltage module

## 6.10 C++ programming (NetSNMP)

Using NetSNMP C++ programs can be easily written for monitoring and control of Mpod low / high voltage modules. For Windows all needed functions are provided by a dynamically loadable library WIENER\_SNMP.DLL. This DLL requires NETSNMP and the WIENER -CRATE-MIB.txt file as described in chapter 6.3!

The following functions are provided in this library (for details see source code):

```
Snmplnit  
Snmplcleanup  
Snmplopen  
Snmplclose  
  
getMainSwitch  
setMainSwitch  
getMainStatus  
getVmeReset  
setVmeReset  
  
getOutputNumber
```

*getOutputGroups*  
*getOutputGroup*  
*getChannelStatus*  
*getOutputSenseMeasurement*  
*getOutputTerminalMeasurement*  
*getCurrentMeasurement*  
*getTemperatureMeasurement*  
*setChannelSwitch*  
*getChannelSwitch*  
*getOutputVoltage*  
*setOutputVoltage*  
*getOutputCurrent*  
*setOutputCurrent*  
*getOutputRiseRate*  
*setOutputRiseRate*  
*getOutputFallRate*  
*setOutputFallRate*  
*getOutputSupervisionBehavior*  
*setOutputSupervisionBehavior*  
*getOutputSupervisionMinSenseVoltage*  
*setOutputSupervisionMinSenseVoltage*  
*getOutputSupervisionMaxSenseVoltage*  
*setOutputSupervisionMaxSenseVoltage*  
*getOutputSupervisionMaxTerminalVoltage*  
*setOutputSupervisionMaxTerminalVoltage*  
*getOutputSupervisionMaxCurrent*  
*setOutputSupervisionMaxCurrent*  
*getOutputSupervisionMaxTemperature*  
*getOutputConfigMaxSenseVoltage*  
*getOutputConfigMaxTerminalVoltage*  
*getOutputConfigMaxCurrent*  
*getOutputConfigMaxPower*

*getSensorNumber*  
*getSensorTemp*  
*getSensorWarningTemperature*  
*setSensorWarningTemperature*  
*getSensorFailureTemperature*  
*setSensorFailureTemperature*

*getPsOperatingTime*

*getFanOperatingTime*  
*getFanAirTemperature*  
*getFanSwitchOffDelay*  
*setFanSwitchOffDelay*  
*getFanNominalSpeed*  
*setFanNominalSpeed*  
*setFanNominalSpeed*  
*getFanNumberOfFans*  
*getFanSpeed*

*snmpSetDouble*

*snmpGetDouble*  
*snmpSetInt*  
*snmpGetInt*

## 7 Mpod Crate

Powered chassis for multichannel low and high voltage modules

<b>Construction</b>	<b>8 or 9U x 19" crate</b>	max.10 modules, up to3 kW output power / 3,6kW input power
	<b>Slots:</b>	10 + ½ (MPOD controller)
	<b>Dimensions (w, h, d)</b>	483 mm x 460 mm x 355 mm
	<b>Weight:</b>	31,5 kg

## 8 Primary Power Supply

The power supply provides all necessary supply voltages for the LV- and HV-Modules. It is connected to the mains (World wide input 100..240V AC, 50..60 Hz).

- World wide input: 100..240V AC, 50..60 Hz, single phase
- Sinusoidal current input, up to 16A, depending on the used modules

### 8.1 Power Box Data Sheet

3U box with max. 6 power modules.

#### Mains Input

<b>Rated Input Voltage:</b>	106 – 230 V AC, +/- 15% variation allowed
<b>Rated Input Current:</b>	16 A
<b>Sinusoidal:</b>	<b>CE</b> CE EN 60555, IEC 555 pow. fact. 0,98 (230VAC)
<b>Inrush current:</b>	16 A, cold unit
<b>Input protection:</b>	An external fuse or circuit breaker has to be installed (16A max.)
<b>RF rejection:</b>	EN 55 022 Class B, Input and Output
<b>Output protection overload:</b>	current limiting for booster circuits, 90°C cut off temperature
<b>Dimensions:</b>	4U x 14 PU width acc. to IEC 60297, 450 mm deep
<b>Weight:</b>	4,7 kg
<b>Operation temperature:</b>	0...45°C without derating, storage: -30°C ... + 85°C
<b>M T B F</b>	electronics: 40°C ambient: ca. 100 000 h
	integrated fan: 40°C ambient: ca. 65 000 h, 25° ambient >85000h

## 9 Mpod Low Voltage module MPV 8xx data sheet

- 8 channel low voltage module with floating outputs with individual return lines and sense lines
- Polarity configurable, outputs are insulated from each other and the chassis mainframe earth with 125V DC working voltage (Test voltage = 500VDC)
- 0.2% / 10K output voltage stability
- Voltage set / monitor: 15 bit resolution, +/-0.1% of full scale or better accuracy, measurement of both sense and terminal voltage
- Current limit set / monitor: 15 bit resolution, +/-0.05% of full scale or better accuracy
- Ramp-up / down programmable from 1 V/s to 500 V/s in 1 V/s steps.
- Output Voltage Ripple: < 10mV<sub>pp</sub>; 1mV<sub>Rms</sub> with 350MHz Bandwidth  
< 5mV<sub>pp</sub>; 0.5mV<sub>Rms</sub> with 100MHz Bandwidth  
< 3mV<sub>pp</sub>; 0.5mV<sub>Rms</sub> with 20MHz Bandwidth
- Low conducted disturbance current (Funkstörstrom TÜV)
- Static Regulation: < 10mV
- Dynamic Regulation: <100mV with I = +/- 25% change and 70A/s  
recovery time < 5mS
- Dimensions: 6U x 40.64mm x 220mm
- Front Panel Indicators: tri-color LED's with on / off / failure for every channel
- Output Channels Connectors:
  - a) 2x 37-pin D-sub (outputs, returns, sense lines, chassis and interlock loop pair)
  - b) 2 x 8 pin high current sub-D and 37-pin sense/control connector
- Interlock Loop – optional
- Safety Loop – in connector PIN 18 and 37

Type	Channel	Voltage	I Max	Peak Power	V-Res	I-Res	Ripple
<b>MPV 8008D</b>	8	0 to 8V	10A	50W / ch.	0.5mV	0.5mA	<30mVpp
<b>MPV 8008I</b>	8	0 to 8V	10A	50W / ch.	0.5mV	0.5mA	<30mVpp
<b>MPV 8008LD</b>	8	0 to 8V	5A	40W / ch.	0.5mV	0.25mA	<10mVpp
<b>MPV 8008LI</b>	8	0 to 8V	5A	40W / ch.	0.5mV	0.25mA	<10mVpp
<b>MPV 8016D</b>	8	0 to 15V	5A	50W / ch.	1mV	0.25mA	<10mVpp
<b>MPV 8016I</b>	8	0 to 15V	5A	50W / ch.	1mV	0.25mA	<10mVpp
<b>MPV 8030D</b>	8	0 to 30V	2.5A	50W / ch.	2mV	0.12mA	<10mVpp
<b>MPV 8030I</b>	8	0 to 30V	2.5A	50W / ch.	2mV	0.12mA	<10mVpp
<b>MPV 8060D</b>	8	0 to 60V	1A	50W / ch.	4mV	0.06mA	<10mVpp
<b>MPV 8060I</b>	8	0 to 60V	1A	50W / ch.	4mV	0.06mA	<10mVpp
<b>MPV 8120D</b>	8	0 to 120V	100mA	50W / ch.	4mV	4 μA	<10mVpp
<b>MPV 8120I</b>	8	0 to 120V	100mA	50W / ch.	4mV	4 μA	<10mVpp

**Regulation fast remote sense circuit (short sensed distance, sense connected to output at the MPOD module):**

Static:	MVP 2-8 V	< 15 mV	(+/-100% load, +/- full mains range)
	MVP other voltages	< 0.05 %	(+/-100% load, +/- full DC input range)
Dynamic (0.5 m wire):	MVP 2-8 V	< 100 mV	(50 % - 75 % load change)
	other	< 0.7 %	(50 % - 75 % load change)
Recovery Time:	MVP 2-8V	1%: 0.2 ms 0.1%: 0.5 ms	(50 % - 75 % load change)
	MVP 5-16V, 7-24V	1%: 0.0 ms 0.1%: 1.0 ms	(50 % - 75 % load change)
	MVP 30-60V	1%: 0.5 ms 0.1%: 1.0 ms	(50 % - 75 % load change)
Conditions	Current slope <1000A/ms, 200uF per 1A parallel to load, fast regulation mode selected.		

**Regulation slow remote sense circuit (long sensed distance):**

Static:	MVP 2-8V/ 30-60V	< 15 mV	(+/-100% load, +/- full mains range)
	Other	< 0.05 %	(+/-100% load, +/- full mains range)
Dynamic:	Dynamic deviation depends on current slope resp. filter capacitors at load side only 30m cable to load, 0,3mF capacitance at load side, 1V drop at nominal load, 10% - 90 % load change with 3ms slope (50A output= 13,33A/ms) leads to less than 10% temporary output voltage deviation		
Recovery Time (40m wire, 5V at load side, $U_{drop} < 2$ V):	MVP 2-7V, 2-8V	10%: <15 ms 1%: <25 ms	(50 % - 75 % load change)
	Other	10%: <15 ms 1%: < 33 ms	(50 % - 75 % load change)





## 10 SNMP examples for MPOD and high voltage EHS/EDS module

```
/******  
/*  
/* SNMP example for control of iseg Multi-Channel High Voltage Power Supply Modules in  
/* a W-IE-NE-R MPOD crate  
/*  
/* snmpget -Oqv -v 2c -M $path -m +WIENER-CRATE-MIB -c public 192.168.16.222 outputVoltage.u100 */  
/* This command will request the value from datapoint set voltage.  
/* snmpget: starts a SNMP request  
/* -v 2c: This parameter specifies which version of the SNMP to use. WIENER devices use SNMP 2C. */  
/* -M $path: This parameter should be replaced with the path to the WIENERCRATE-MIB.txt file. */  
/* It is not needed in case the default path is used.  
/* -m +WIENER-CRATE-MIB: This parameter tells the command to look at the WIENER-CRATE-MIB */  
/* to resolve the OID name.  
/* -c public: This specifies which community of values can be accessed  
/* 192.168.16.222: The IP address of the MPOD crate.  
/* outputVoltage.u100: The SNMP item to the data point set voltage of a module in the second */  
/* slot of the MPOD crate HV channel 0.  
/*  
/* snmpset -Oqv -v 2c -m +WIENER-CRATE-MIB -c public 192.168.16.222 outputVoltage.u100 F 60 */  
/* This command writes a floating point value to the datapoint set voltage.  
/* snmpset: starts a SNMP write instruction  
/* -c guru: This specifies the community for write accesses  
/* F 60: The F specifies the write value as a floating point formatted value.  
/* The 60 is the write value 60 Volt.  
/*  
/* snmpset -Oqv -v 2c -m +WIENER-CRATE-MIB -c guru 192.168.16.222 outputSwitch.u100 i 1 */  
/* This command write a switch on of the HV for one channel.  
/* outputSwitch.u100 i 1: Write of an integer formatted value to the item outputSwitch. */  
/* With that item it is possible to switch differnt functions for instance */  
/* set On(1).  
/******
```

```
snmpget -Oqv -v 2c -m +WIENER-CRATE-MIB -c public 192.168.16.222 outputVoltage.u100  
200.000000 V
```

```
snmpset -Oqv -v 2c -m +WIENER-CRATE-MIB -c guru 192.168.16.222 outputVoltage.u100 F 60  
60.000000 V
```

```
snmpset -Oqv -v 2c -m +WIENER-CRATE-MIB -c guru 192.168.16.222 outputSwitch.u100 i 1  
On
```

```
snmpget -Oqv -v 2c -m +WIENER-CRATE-MIB -c public 192.168.16.222 outputVoltage.u100  
60.000000 V
```

```
snmpget -Oqv -v 2c -m +WIENER-CRATE-MIB -c public 192.168.16.222 outputMeasurementSenseVoltage.u100  
60.104588 V
```

```
snmpget -Oqv -v 2c -m +WIENER-CRATE-MIB -c public 192.168.16.222 outputMeasurementSenseVoltage.u100  
60.104713 V
```

```
snmpget -Oqv -v 2c -m +WIENER-CRATE-MIB -c public 192.168.16.222 outputMeasurementCurrent.u100  
0.000001 A
```

```
snmpgetx -Oqv -v 2c -m +WIENER-CRATE-MIB -c public 192.168.16.222 outputMeasurementCurrent.u100  
0.000000735 A
```

```
snmpget -Oqv -v 2c -m +WIENER-CRATE-MIB -c public 192.168.16.222 outputSupervisionBehavior.u100  
0
```

```
snmpset -Oqv -v 2c -m +WIENER-CRATE-MIB -c guru 192.168.16.222 outputSupervisionBehavior.u100 i 64  
64
```

```

snmpget -Oqv -v 2c -m +WIENER-CRATE-MIB -c public 192.168.16.222 outputSupervisionBehavior.u100
64

snmpget -Oqv -v 2c -m +WIENER-CRATE-MIB -c public 192.168.16.222 outputTripTimeMaxCurrent.u100
0 ms

snmpset -Oqv -v 2c -m +WIENER-CRATE-MIB -c guru 192.168.16.222 outputTripTimeMaxCurrent.u100 i 3000
3000 ms /* delay of 3 sconds */

snmpget -Oqv -v 2c -m +WIENER-CRATE-MIB -c public 192.168.16.222 outputStatus.u100
"80 " /* outputOn */

snmpgetx -Oqv -v 2c -m +WIENER-CRATE-MIB -c public 192.168.16.222 outputMeasurementCurrent.u100
0.000000735 A

snmpsetx -Oqv -v 2c -m +WIENER-CRATE-MIB -c guru 192.168.16.222 outputCurrent.u100 F 0.0000007
0.000000700 A

snmpget -Oqv -v 2c -m +WIENER-CRATE-MIB -c public 192.168.16.222 outputStatus.u100
"04 08 " /*outputFailureMaxCurrent, outputRampDown */

snmpget -Oqv -v 2c -m +WIENER-CRATE-MIB -c public 192.168.16.222 outputStatus.u100
"04 " /* outputFailureMaxCurrent */

snmpset -Oqv -v 2c -m +WIENER-CRATE-MIB -c guru 192.168.16.222 outputSwitch.u100 i 10
clearEvents

snmpsetx -Oqv -v 2c -m +WIENER-CRATE-MIB -c guru 192.168.16.222 outputCurrent.u100 F 0.00001
0.000010000 A

snmpset -Oqv -v 2c -m +WIENER-CRATE-MIB -c guru 192.168.16.222 outputSwitch.u100 i 1
On

snmpget -Oqv -v 2c -m +WIENER-CRATE-MIB -c public 192.168.16.222 outputStatus.u100
"80 10 " /* outputOn, outputRampUp */

/* a load has been switched on channel 0 to bring them in state CC current limited */
snmpget -Oqv -v 2c -m +WIENER-CRATE-MIB -c public 192.168.16.222 outputStatus.u100
"80 20 " /* outputOn, outputCurrentLimited */

snmpget -Oqv -v 2c -m +WIENER-CRATE-MIB -c public 192.168.16.222 outputStatus.u100
"80 20 " /* outputOn, outputCurrentLimited */

snmpget -Oqv -v 2c -m +WIENER-CRATE-MIB -c public 192.168.16.222 outputStatus.u100
"80 20 " /* outputOn, outputCurrentLimited */

snmpget -Oqv -v 2c -m +WIENER-CRATE-MIB -c public 192.168.16.222 outputStatus.u100
"80 20 " /* outputOn, outputCurrentLimited */

/* the delayed trip fuction pamps the voltage after 3 seconds to zero */
snmpget -Oqv -v 2c -m +WIENER-CRATE-MIB -c public 192.168.16.222 outputStatus.u100
"04 08 " /* outputFailureMaxCurrent, outputRampDown */

snmpget -Oqv -v 2c -m +WIENER-CRATE-MIB -c public 192.168.16.222 outputStatus.u100
"04 08 " /* outputFailureMaxCurrent, outputRampDown */

```

## 11 WIENER SNMP Parameter structure

```
// GENERATED WITH
// snmptranslate -w 120 -Tp WIENER-CRATE-MIB::crate > SnmpTree.txt
//

+--crate(1)
  +--system(1)
    | +-- -RW- EnumVal sysMainSwitch(1)
    | | Values: off(0), on(1)
    | +-- -R-- BitString sysStatus(2)
    | | Values: mainOn(0), mainInhibit(1), localControlOnly(2), inputFailure(3), outputFailure(4),
    | | fantrayFailure(5), sensorFailure(6), vmeSysfail(7), plugAndPlayIncompatible(8)
    | +-- -RW- EnumVal sysVmeSysReset(3)
    | | Values: trigger(1)
    | +-- -RW- INTEGER sysHardwareReset(4)
    | +-- -RW- BitString sysConfigDoMeasurementCurrent(10)
    | | Values: ch0(0), ch1(1), ch2(2), ch3(3), ch4(4), ch5(5), ch6(6), ch7(7)
    | +-- -RW- Integer32 sysOperatingTime(11)
    | +-- -RW- String sysMemoryAccess(127)
    | | Size: 516
    | +-- -RW- Integer32 sysDebugMemory8(1024)
    | | Range: 0..255
    | +-- -RW- Integer32 sysDebugMemory16(1025)
    | | Range: 0..65535
    | +-- -RW- Integer32 sysDebugMemory32(1026)
    | | Range: -2147483648..2147483647
    |
    +--input(2)
    +--output(3)
      | +-- -R-- Integer32 outputNumber(1)
      | | Range: 0..1999
      |
      +--outputTable(2)
        | |
        | +--outputEntry(1)
        | | Index: outputIndex
        | |
        | +-- ---- EnumVal outputIndex(1)
        | | Values: u0(1), u1(2), u2(3), u3(4), u4(5), u5(6), u6(7), u7(8), u8(9), u9(10), u10(11), u11(12),
        | | u12(13), u13(14), u14(15), u15(16), u16(17), u17(18), u18(19), u19(20), u20(21), u21(22),
        | | u22(23), u23(24), u24(25), u25(26), u26(27), u27(28), u28(29), u29(30), u30(31), u31(32),
        | | u32(33), u33(34), u34(35), u35(36), u36(37), u37(38), u38(39), u39(40), u40(41), u41(42),
        | | u42(43), u43(44), u44(45), u45(46), u46(47), u47(48), u48(49), u49(50), u50(51), u51(52),
        | | u52(53), u53(54), u54(55), u55(56), u56(57), u57(58), u58(59), u59(60), u60(61), u61(62),
        | | u62(63), u63(64), u64(65), u65(66), u66(67), u67(68), u68(69), u69(70), u70(71), u71(72),
        | | u72(73), u73(74), u74(75), u75(76), u76(77), u77(78), u78(79), u79(80), u80(81), u81(82),
        | | u82(83), u83(84), u84(85), u85(86), u86(87), u87(88), u88(89), u89(90), u90(91), u91(92),
        | | u92(93), u93(94), u94(95), u95(96), u96(97), u97(98), u98(99), u99(100), u100(101),
        | | u101(102), u102(103), u103(104), u104(105), u105(106), u106(107), u107(108), u108(109),
        | | u109(110), u110(111), u111(112), u112(113), u113(114), u114(115), u115(116), u116(117),
        | | u117(118), u118(119), u119(120), u120(121), u121(122), u122(123), u123(124), u124(125),
        | | u125(126), u126(127), u127(128), u128(129), u129(130), u130(131), u131(132), u132(133),
        | | u133(134), u134(135), u135(136), u136(137), u137(138), u138(139), u139(140), u140(141),
        | | u141(142), u142(143), u143(144), u144(145), u145(146), u146(147), u147(148), u148(149),
        | | u149(150), u150(151), u151(152), u152(153), u153(154), u154(155), u155(156), u156(157),
        | | u157(158), u158(159), u159(160), u160(161), u161(162), u162(163), u163(164), u164(165),
        | | u165(166), u166(167), u167(168), u168(169), u169(170), u170(171), u171(172), u172(173),
        | | u173(174), u174(175), u175(176), u176(177), u177(178), u178(179), u179(180), u180(181),
        | | u181(182), u182(183), u183(184), u184(185), u185(186), u186(187), u187(188), u188(189),
        | | u189(190), u190(191), u191(192), u192(193), u193(194), u194(195), u195(196), u196(197),
        | | u197(198), u198(199), u199(200), u200(201), u201(202), u202(203), u203(204), u204(205),
        | | u205(206), u206(207), u207(208), u208(209), u209(210), u210(211), u211(212), u212(213),
```

u213(214), u214(215), u215(216), u216(217), u217(218), u218(219), u219(220), u220(221),  
u221(222), u222(223), u223(224), u224(225), u225(226), u226(227), u227(228), u228(229),  
u229(230), u230(231), u231(232), u232(233), u233(234), u234(235), u235(236), u236(237),  
u237(238), u238(239), u239(240), u240(241), u241(242), u242(243), u243(244), u244(245),  
u245(246), u246(247), u247(248), u248(249), u249(250), u250(251), u251(252), u252(253),  
u253(254), u254(255), u255(256), u256(257), u257(258), u258(259), u259(260), u260(261),  
u261(262), u262(263), u263(264), u264(265), u265(266), u266(267), u267(268), u268(269),  
u269(270), u270(271), u271(272), u272(273), u273(274), u274(275), u275(276), u276(277),  
u277(278), u278(279), u279(280), u280(281), u281(282), u282(283), u283(284), u284(285),  
u285(286), u286(287), u287(288), u288(289), u289(290), u290(291), u291(292), u292(293),  
u293(294), u294(295), u295(296), u296(297), u297(298), u298(299), u299(300), u300(301),  
u301(302), u302(303), u303(304), u304(305), u305(306), u306(307), u307(308), u308(309),  
u309(310), u310(311), u311(312), u312(313), u313(314), u314(315), u315(316), u316(317),  
u317(318), u318(319), u319(320), u320(321), u321(322), u322(323), u323(324), u324(325),  
u325(326), u326(327), u327(328), u328(329), u329(330), u330(331), u331(332), u332(333),  
u333(334), u334(335), u335(336), u336(337), u337(338), u338(339), u339(340), u340(341),  
u341(342), u342(343), u343(344), u344(345), u345(346), u346(347), u347(348), u348(349),  
u349(350), u350(351), u351(352), u352(353), u353(354), u354(355), u355(356), u356(357),  
u357(358), u358(359), u359(360), u360(361), u361(362), u362(363), u363(364), u364(365),  
u365(366), u366(367), u367(368), u368(369), u369(370), u370(371), u371(372), u372(373),  
u373(374), u374(375), u375(376), u376(377), u377(378), u378(379), u379(380), u380(381),  
u381(382), u382(383), u383(384), u384(385), u385(386), u386(387), u387(388), u388(389),  
u389(390), u390(391), u391(392), u392(393), u393(394), u394(395), u395(396), u396(397),  
u397(398), u398(399), u399(400), u400(401), u401(402), u402(403), u403(404), u404(405),  
u405(406), u406(407), u407(408), u408(409), u409(410), u410(411), u411(412), u412(413),  
u413(414), u414(415), u415(416), u416(417), u417(418), u418(419), u419(420), u420(421),  
u421(422), u422(423), u423(424), u424(425), u425(426), u426(427), u427(428), u428(429),  
u429(430), u430(431), u431(432), u432(433), u433(434), u434(435), u435(436), u436(437),  
u437(438), u438(439), u439(440), u440(441), u441(442), u442(443), u443(444), u444(445),  
u445(446), u446(447), u447(448), u448(449), u449(450), u450(451), u451(452), u452(453),  
u453(454), u454(455), u455(456), u456(457), u457(458), u458(459), u459(460), u460(461),  
u461(462), u462(463), u463(464), u464(465), u465(466), u466(467), u467(468), u468(469),  
u469(470), u470(471), u471(472), u472(473), u473(474), u474(475), u475(476), u476(477),  
u477(478), u478(479), u479(480), u480(481), u481(482), u482(483), u483(484), u484(485),  
u485(486), u486(487), u487(488), u488(489), u489(490), u490(491), u491(492), u492(493),  
u493(494), u494(495), u495(496), u496(497), u497(498), u498(499), u499(500), u500(501),  
u501(502), u502(503), u503(504), u504(505), u505(506), u506(507), u507(508), u508(509),  
u509(510), u510(511), u511(512), u512(513), u513(514), u514(515), u515(516), u516(517),  
u517(518), u518(519), u519(520), u520(521), u521(522), u522(523), u523(524), u524(525),  
u525(526), u526(527), u527(528), u528(529), u529(530), u530(531), u531(532), u532(533),  
u533(534), u534(535), u535(536), u536(537), u537(538), u538(539), u539(540), u540(541),  
u541(542), u542(543), u543(544), u544(545), u545(546), u546(547), u547(548), u548(549),  
u549(550), u550(551), u551(552), u552(553), u553(554), u554(555), u555(556), u556(557),  
u557(558), u558(559), u559(560), u560(561), u561(562), u562(563), u563(564), u564(565),  
u565(566), u566(567), u567(568), u568(569), u569(570), u570(571), u571(572), u572(573),  
u573(574), u574(575), u575(576), u576(577), u577(578), u578(579), u579(580), u580(581),  
u581(582), u582(583), u583(584), u584(585), u585(586), u586(587), u587(588), u588(589),  
u589(590), u590(591), u591(592), u592(593), u593(594), u594(595), u595(596), u596(597),  
u597(598), u598(599), u599(600), u600(601), u601(602), u602(603), u603(604), u604(605),  
u605(606), u606(607), u607(608), u608(609), u609(610), u610(611), u611(612), u612(613),  
u613(614), u614(615), u615(616), u616(617), u617(618), u618(619), u619(620), u620(621),  
u621(622), u622(623), u623(624), u624(625), u625(626), u626(627), u627(628), u628(629),  
u629(630), u630(631), u631(632), u632(633), u633(634), u634(635), u635(636), u636(637),  
u637(638), u638(639), u639(640), u640(641), u641(642), u642(643), u643(644), u644(645),  
u645(646), u646(647), u647(648), u648(649), u649(650), u650(651), u651(652), u652(653),  
u653(654), u654(655), u655(656), u656(657), u657(658), u658(659), u659(660), u660(661),  
u661(662), u662(663), u663(664), u664(665), u665(666), u666(667), u667(668), u668(669),  
u669(670), u670(671), u671(672), u672(673), u673(674), u674(675), u675(676), u676(677),  
u677(678), u678(679), u679(680), u680(681), u681(682), u682(683), u683(684), u684(685),  
u685(686), u686(687), u687(688), u688(689), u689(690), u690(691), u691(692), u692(693),  
u693(694), u694(695), u695(696), u696(697), u697(698), u698(699), u699(700), u700(701),  
u701(702), u702(703), u703(704), u704(705), u705(706), u706(707), u707(708), u708(709),  
u709(710), u710(711), u711(712), u712(713), u713(714), u714(715), u715(716), u716(717),  
u717(718), u718(719), u719(720), u720(721), u721(722), u722(723), u723(724), u724(725),

u725(726), u726(727), u727(728), u728(729), u729(730), u730(731), u731(732), u732(733),  
u733(734), u734(735), u735(736), u736(737), u737(738), u738(739), u739(740), u740(741),  
u741(742), u742(743), u743(744), u744(745), u745(746), u746(747), u747(748), u748(749),  
u749(750), u750(751), u751(752), u752(753), u753(754), u754(755), u755(756), u756(757),  
u757(758), u758(759), u759(760), u760(761), u761(762), u762(763), u763(764), u764(765),  
u765(766), u766(767), u767(768), u768(769), u769(770), u770(771), u771(772), u772(773),  
u773(774), u774(775), u775(776), u776(777), u777(778), u778(779), u779(780), u780(781),  
u781(782), u782(783), u783(784), u784(785), u785(786), u786(787), u787(788), u788(789),  
u789(790), u790(791), u791(792), u792(793), u793(794), u794(795), u795(796), u796(797),  
u797(798), u798(799), u799(800), u800(801), u801(802), u802(803), u803(804), u804(805),  
u805(806), u806(807), u807(808), u808(809), u809(810), u810(811), u811(812), u812(813),  
u813(814), u814(815), u815(816), u816(817), u817(818), u818(819), u819(820), u820(821),  
u821(822), u822(823), u823(824), u824(825), u825(826), u826(827), u827(828), u828(829),  
u829(830), u830(831), u831(832), u832(833), u833(834), u834(835), u835(836), u836(837),  
u837(838), u838(839), u839(840), u840(841), u841(842), u842(843), u843(844), u844(845),  
u845(846), u846(847), u847(848), u848(849), u849(850), u850(851), u851(852), u852(853),  
u853(854), u854(855), u855(856), u856(857), u857(858), u858(859), u859(860), u860(861),  
u861(862), u862(863), u863(864), u864(865), u865(866), u866(867), u867(868), u868(869),  
u869(870), u870(871), u871(872), u872(873), u873(874), u874(875), u875(876), u876(877),  
u877(878), u878(879), u879(880), u880(881), u881(882), u882(883), u883(884), u884(885),  
u885(886), u886(887), u887(888), u888(889), u889(890), u890(891), u891(892), u892(893),  
u893(894), u894(895), u895(896), u896(897), u897(898), u898(899), u899(900), u900(901),  
u901(902), u902(903), u903(904), u904(905), u905(906), u906(907), u907(908), u908(909),  
u909(910), u910(911), u911(912), u912(913), u913(914), u914(915), u915(916), u916(917),  
u917(918), u918(919), u919(920), u920(921), u921(922), u922(923), u923(924), u924(925),  
u925(926), u926(927), u927(928), u928(929), u929(930), u930(931), u931(932), u932(933),  
u933(934), u934(935), u935(936), u936(937), u937(938), u938(939), u939(940), u940(941),  
u941(942), u942(943), u943(944), u944(945), u945(946), u946(947), u947(948), u948(949),  
u949(950), u950(951), u951(952), u952(953), u953(954), u954(955), u955(956), u956(957),  
u957(958), u958(959), u959(960), u960(961), u961(962), u962(963), u963(964), u964(965),  
u965(966), u966(967), u967(968), u968(969), u969(970), u970(971), u971(972), u972(973),  
u973(974), u974(975), u975(976), u976(977), u977(978), u978(979), u979(980), u980(981),  
u981(982), u982(983), u983(984), u984(985), u985(986), u986(987), u987(988), u988(989),  
u989(990), u990(991), u991(992), u992(993), u993(994), u994(995), u995(996), u996(997),  
u997(998), u998(999), u999(1000), u1000(1001), u1001(1002), u1002(1003), u1003(1004),  
u1004(1005), u1005(1006), u1006(1007), u1007(1008), u1008(1009), u1009(1010),  
u1010(1011), u1011(1012), u1012(1013), u1013(1014), u1014(1015), u1015(1016),  
u1016(1017), u1017(1018), u1018(1019), u1019(1020), u1020(1021), u1021(1022),  
u1022(1023), u1023(1024), u1024(1025), u1025(1026), u1026(1027), u1027(1028),  
u1028(1029), u1029(1030), u1030(1031), u1031(1032), u1032(1033), u1033(1034),  
u1034(1035), u1035(1036), u1036(1037), u1037(1038), u1038(1039), u1039(1040),  
u1040(1041), u1041(1042), u1042(1043), u1043(1044), u1044(1045), u1045(1046),  
u1046(1047), u1047(1048), u1048(1049), u1049(1050), u1050(1051), u1051(1052),  
u1052(1053), u1053(1054), u1054(1055), u1055(1056), u1056(1057), u1057(1058),  
u1058(1059), u1059(1060), u1060(1061), u1061(1062), u1062(1063), u1063(1064),  
u1064(1065), u1065(1066), u1066(1067), u1067(1068), u1068(1069), u1069(1070),  
u1070(1071), u1071(1072), u1072(1073), u1073(1074), u1074(1075), u1075(1076),  
u1076(1077), u1077(1078), u1078(1079), u1079(1080), u1080(1081), u1081(1082),  
u1082(1083), u1083(1084), u1084(1085), u1085(1086), u1086(1087), u1087(1088),  
u1088(1089), u1089(1090), u1090(1091), u1091(1092), u1092(1093), u1093(1094),  
u1094(1095), u1095(1096), u1096(1097), u1097(1098), u1098(1099), u1099(1100),  
u1100(1101), u1101(1102), u1102(1103), u1103(1104), u1104(1105), u1105(1106),  
u1106(1107), u1107(1108), u1108(1109), u1109(1110), u1110(1111), u1111(1112),  
u1112(1113), u1113(1114), u1114(1115), u1115(1116), u1116(1117), u1117(1118),  
u1118(1119), u1119(1120), u1120(1121), u1121(1122), u1122(1123), u1123(1124),  
u1124(1125), u1125(1126), u1126(1127), u1127(1128), u1128(1129), u1129(1130),  
u1130(1131), u1131(1132), u1132(1133), u1133(1134), u1134(1135), u1135(1136),  
u1136(1137), u1137(1138), u1138(1139), u1139(1140), u1140(1141), u1141(1142),  
u1142(1143), u1143(1144), u1144(1145), u1145(1146), u1146(1147), u1147(1148),  
u1148(1149), u1149(1150), u1150(1151), u1151(1152), u1152(1153), u1153(1154),  
u1154(1155), u1155(1156), u1156(1157), u1157(1158), u1158(1159), u1159(1160),  
u1160(1161), u1161(1162), u1162(1163), u1163(1164), u1164(1165), u1165(1166),  
u1166(1167), u1167(1168), u1168(1169), u1169(1170), u1170(1171), u1171(1172),  
u1172(1173), u1173(1174), u1174(1175), u1175(1176), u1176(1177), u1177(1178),

u1178(1179), u1179(1180), u1180(1181), u1181(1182), u1182(1183), u1183(1184),  
u1184(1185), u1185(1186), u1186(1187), u1187(1188), u1188(1189), u1189(1190),  
u1190(1191), u1191(1192), u1192(1193), u1193(1194), u1194(1195), u1195(1196),  
u1196(1197), u1197(1198), u1198(1199), u1199(1200), u1200(1201), u1201(1202),  
u1202(1203), u1203(1204), u1204(1205), u1205(1206), u1206(1207), u1207(1208),  
u1208(1209), u1209(1210), u1210(1211), u1211(1212), u1212(1213), u1213(1214),  
u1214(1215), u1215(1216), u1216(1217), u1217(1218), u1218(1219), u1219(1220),  
u1220(1221), u1221(1222), u1222(1223), u1223(1224), u1224(1225), u1225(1226),  
u1226(1227), u1227(1228), u1228(1229), u1229(1230), u1230(1231), u1231(1232),  
u1232(1233), u1233(1234), u1234(1235), u1235(1236), u1236(1237), u1237(1238),  
u1238(1239), u1239(1240), u1240(1241), u1241(1242), u1242(1243), u1243(1244),  
u1244(1245), u1245(1246), u1246(1247), u1247(1248), u1248(1249), u1249(1250),  
u1250(1251), u1251(1252), u1252(1253), u1253(1254), u1254(1255), u1255(1256),  
u1256(1257), u1257(1258), u1258(1259), u1259(1260), u1260(1261), u1261(1262),  
u1262(1263), u1263(1264), u1264(1265), u1265(1266), u1266(1267), u1267(1268),  
u1268(1269), u1269(1270), u1270(1271), u1271(1272), u1272(1273), u1273(1274),  
u1274(1275), u1275(1276), u1276(1277), u1277(1278), u1278(1279), u1279(1280),  
u1280(1281), u1281(1282), u1282(1283), u1283(1284), u1284(1285), u1285(1286),  
u1286(1287), u1287(1288), u1288(1289), u1289(1290), u1290(1291), u1291(1292),  
u1292(1293), u1293(1294), u1294(1295), u1295(1296), u1296(1297), u1297(1298),  
u1298(1299), u1299(1300), u1300(1301), u1301(1302), u1302(1303), u1303(1304),  
u1304(1305), u1305(1306), u1306(1307), u1307(1308), u1308(1309), u1309(1310),  
u1310(1311), u1311(1312), u1312(1313), u1313(1314), u1314(1315), u1315(1316),  
u1316(1317), u1317(1318), u1318(1319), u1319(1320), u1320(1321), u1321(1322),  
u1322(1323), u1323(1324), u1324(1325), u1325(1326), u1326(1327), u1327(1328),  
u1328(1329), u1329(1330), u1330(1331), u1331(1332), u1332(1333), u1333(1334),  
u1334(1335), u1335(1336), u1336(1337), u1337(1338), u1338(1339), u1339(1340),  
u1340(1341), u1341(1342), u1342(1343), u1343(1344), u1344(1345), u1345(1346),  
u1346(1347), u1347(1348), u1348(1349), u1349(1350), u1350(1351), u1351(1352),  
u1352(1353), u1353(1354), u1354(1355), u1355(1356), u1356(1357), u1357(1358),  
u1358(1359), u1359(1360), u1360(1361), u1361(1362), u1362(1363), u1363(1364),  
u1364(1365), u1365(1366), u1366(1367), u1367(1368), u1368(1369), u1369(1370),  
u1370(1371), u1371(1372), u1372(1373), u1373(1374), u1374(1375), u1375(1376),  
u1376(1377), u1377(1378), u1378(1379), u1379(1380), u1380(1381), u1381(1382),  
u1382(1383), u1383(1384), u1384(1385), u1385(1386), u1386(1387), u1387(1388),  
u1388(1389), u1389(1390), u1390(1391), u1391(1392), u1392(1393), u1393(1394),  
u1394(1395), u1395(1396), u1396(1397), u1397(1398), u1398(1399), u1399(1400),  
u1400(1401), u1401(1402), u1402(1403), u1403(1404), u1404(1405), u1405(1406),  
u1406(1407), u1407(1408), u1408(1409), u1409(1410), u1410(1411), u1411(1412),  
u1412(1413), u1413(1414), u1414(1415), u1415(1416), u1416(1417), u1417(1418),  
u1418(1419), u1419(1420), u1420(1421), u1421(1422), u1422(1423), u1423(1424),  
u1424(1425), u1425(1426), u1426(1427), u1427(1428), u1428(1429), u1429(1430),  
u1430(1431), u1431(1432), u1432(1433), u1433(1434), u1434(1435), u1435(1436),  
u1436(1437), u1437(1438), u1438(1439), u1439(1440), u1440(1441), u1441(1442),  
u1442(1443), u1443(1444), u1444(1445), u1445(1446), u1446(1447), u1447(1448),  
u1448(1449), u1449(1450), u1450(1451), u1451(1452), u1452(1453), u1453(1454),  
u1454(1455), u1455(1456), u1456(1457), u1457(1458), u1458(1459), u1459(1460),  
u1460(1461), u1461(1462), u1462(1463), u1463(1464), u1464(1465), u1465(1466),  
u1466(1467), u1467(1468), u1468(1469), u1469(1470), u1470(1471), u1471(1472),  
u1472(1473), u1473(1474), u1474(1475), u1475(1476), u1476(1477), u1477(1478),  
u1478(1479), u1479(1480), u1480(1481), u1481(1482), u1482(1483), u1483(1484),  
u1484(1485), u1485(1486), u1486(1487), u1487(1488), u1488(1489), u1489(1490),  
u1490(1491), u1491(1492), u1492(1493), u1493(1494), u1494(1495), u1495(1496),  
u1496(1497), u1497(1498), u1498(1499), u1499(1500), u1500(1501), u1501(1502),  
u1502(1503), u1503(1504), u1504(1505), u1505(1506), u1506(1507), u1507(1508),  
u1508(1509), u1509(1510), u1510(1511), u1511(1512), u1512(1513), u1513(1514),  
u1514(1515), u1515(1516), u1516(1517), u1517(1518), u1518(1519), u1519(1520),  
u1520(1521), u1521(1522), u1522(1523), u1523(1524), u1524(1525), u1525(1526),  
u1526(1527), u1527(1528), u1528(1529), u1529(1530), u1530(1531), u1531(1532),  
u1532(1533), u1533(1534), u1534(1535), u1535(1536), u1536(1537), u1537(1538),  
u1538(1539), u1539(1540), u1540(1541), u1541(1542), u1542(1543), u1543(1544),  
u1544(1545), u1545(1546), u1546(1547), u1547(1548), u1548(1549), u1549(1550),  
u1550(1551), u1551(1552), u1552(1553), u1553(1554), u1554(1555), u1555(1556),  
u1556(1557), u1557(1558), u1558(1559), u1559(1560), u1560(1561), u1561(1562),

u1562(1563), u1563(1564), u1564(1565), u1565(1566), u1566(1567), u1567(1568),  
u1568(1569), u1569(1570), u1570(1571), u1571(1572), u1572(1573), u1573(1574),  
u1574(1575), u1575(1576), u1576(1577), u1577(1578), u1578(1579), u1579(1580),  
u1580(1581), u1581(1582), u1582(1583), u1583(1584), u1584(1585), u1585(1586),  
u1586(1587), u1587(1588), u1588(1589), u1589(1590), u1590(1591), u1591(1592),  
u1592(1593), u1593(1594), u1594(1595), u1595(1596), u1596(1597), u1597(1598),  
u1598(1599), u1599(1600), u1600(1601), u1601(1602), u1602(1603), u1603(1604),  
u1604(1605), u1605(1606), u1606(1607), u1607(1608), u1608(1609), u1609(1610),  
u1610(1611), u1611(1612), u1612(1613), u1613(1614), u1614(1615), u1615(1616),  
u1616(1617), u1617(1618), u1618(1619), u1619(1620), u1620(1621), u1621(1622),  
u1622(1623), u1623(1624), u1624(1625), u1625(1626), u1626(1627), u1627(1628),  
u1628(1629), u1629(1630), u1630(1631), u1631(1632), u1632(1633), u1633(1634),  
u1634(1635), u1635(1636), u1636(1637), u1637(1638), u1638(1639), u1639(1640),  
u1640(1641), u1641(1642), u1642(1643), u1643(1644), u1644(1645), u1645(1646),  
u1646(1647), u1647(1648), u1648(1649), u1649(1650), u1650(1651), u1651(1652),  
u1652(1653), u1653(1654), u1654(1655), u1655(1656), u1656(1657), u1657(1658),  
u1658(1659), u1659(1660), u1660(1661), u1661(1662), u1662(1663), u1663(1664),  
u1664(1665), u1665(1666), u1666(1667), u1667(1668), u1668(1669), u1669(1670),  
u1670(1671), u1671(1672), u1672(1673), u1673(1674), u1674(1675), u1675(1676),  
u1676(1677), u1677(1678), u1678(1679), u1679(1680), u1680(1681), u1681(1682),  
u1682(1683), u1683(1684), u1684(1685), u1685(1686), u1686(1687), u1687(1688),  
u1688(1689), u1689(1690), u1690(1691), u1691(1692), u1692(1693), u1693(1694),  
u1694(1695), u1695(1696), u1696(1697), u1697(1698), u1698(1699), u1699(1700),  
u1700(1701), u1701(1702), u1702(1703), u1703(1704), u1704(1705), u1705(1706),  
u1706(1707), u1707(1708), u1708(1709), u1709(1710), u1710(1711), u1711(1712),  
u1712(1713), u1713(1714), u1714(1715), u1715(1716), u1716(1717), u1717(1718),  
u1718(1719), u1719(1720), u1720(1721), u1721(1722), u1722(1723), u1723(1724),  
u1724(1725), u1725(1726), u1726(1727), u1727(1728), u1728(1729), u1729(1730),  
u1730(1731), u1731(1732), u1732(1733), u1733(1734), u1734(1735), u1735(1736),  
u1736(1737), u1737(1738), u1738(1739), u1739(1740), u1740(1741), u1741(1742),  
u1742(1743), u1743(1744), u1744(1745), u1745(1746), u1746(1747), u1747(1748),  
u1748(1749), u1749(1750), u1750(1751), u1751(1752), u1752(1753), u1753(1754),  
u1754(1755), u1755(1756), u1756(1757), u1757(1758), u1758(1759), u1759(1760),  
u1760(1761), u1761(1762), u1762(1763), u1763(1764), u1764(1765), u1765(1766),  
u1766(1767), u1767(1768), u1768(1769), u1769(1770), u1770(1771), u1771(1772),  
u1772(1773), u1773(1774), u1774(1775), u1775(1776), u1776(1777), u1777(1778),  
u1778(1779), u1779(1780), u1780(1781), u1781(1782), u1782(1783), u1783(1784),  
u1784(1785), u1785(1786), u1786(1787), u1787(1788), u1788(1789), u1789(1790),  
u1790(1791), u1791(1792), u1792(1793), u1793(1794), u1794(1795), u1795(1796),  
u1796(1797), u1797(1798), u1798(1799), u1799(1800), u1800(1801), u1801(1802),  
u1802(1803), u1803(1804), u1804(1805), u1805(1806), u1806(1807), u1807(1808),  
u1808(1809), u1809(1810), u1810(1811), u1811(1812), u1812(1813), u1813(1814),  
u1814(1815), u1815(1816), u1816(1817), u1817(1818), u1818(1819), u1819(1820),  
u1820(1821), u1821(1822), u1822(1823), u1823(1824), u1824(1825), u1825(1826),  
u1826(1827), u1827(1828), u1828(1829), u1829(1830), u1830(1831), u1831(1832),  
u1832(1833), u1833(1834), u1834(1835), u1835(1836), u1836(1837), u1837(1838),  
u1838(1839), u1839(1840), u1840(1841), u1841(1842), u1842(1843), u1843(1844),  
u1844(1845), u1845(1846), u1846(1847), u1847(1848), u1848(1849), u1849(1850),  
u1850(1851), u1851(1852), u1852(1853), u1853(1854), u1854(1855), u1855(1856),  
u1856(1857), u1857(1858), u1858(1859), u1859(1860), u1860(1861), u1861(1862),  
u1862(1863), u1863(1864), u1864(1865), u1865(1866), u1866(1867), u1867(1868),  
u1868(1869), u1869(1870), u1870(1871), u1871(1872), u1872(1873), u1873(1874),  
u1874(1875), u1875(1876), u1876(1877), u1877(1878), u1878(1879), u1879(1880),  
u1880(1881), u1881(1882), u1882(1883), u1883(1884), u1884(1885), u1885(1886),  
u1886(1887), u1887(1888), u1888(1889), u1889(1890), u1890(1891), u1891(1892),  
u1892(1893), u1893(1894), u1894(1895), u1895(1896), u1896(1897), u1897(1898),  
u1898(1899), u1899(1900), u1900(1901), u1901(1902), u1902(1903), u1903(1904),  
u1904(1905), u1905(1906), u1906(1907), u1907(1908), u1908(1909), u1909(1910),  
u1910(1911), u1911(1912), u1912(1913), u1913(1914), u1914(1915), u1915(1916),  
u1916(1917), u1917(1918), u1918(1919), u1919(1920), u1920(1921), u1921(1922),  
u1922(1923), u1923(1924), u1924(1925), u1925(1926), u1926(1927), u1927(1928),  
u1928(1929), u1929(1930), u1930(1931), u1931(1932), u1932(1933), u1933(1934),  
u1934(1935), u1935(1936), u1936(1937), u1937(1938), u1938(1939), u1939(1940),  
u1940(1941), u1941(1942), u1942(1943), u1943(1944), u1944(1945), u1945(1946),



```

| | | u1946(1947), u1947(1948), u1948(1949), u1949(1950), u1950(1951), u1951(1952),
| | | u1952(1953), u1953(1954), u1954(1955), u1955(1956), u1956(1957), u1957(1958),
| | | u1958(1959), u1959(1960), u1960(1961), u1961(1962), u1962(1963), u1963(1964),
| | | u1964(1965), u1965(1966), u1966(1967), u1967(1968), u1968(1969), u1969(1970),
| | | u1970(1971), u1971(1972), u1972(1973), u1973(1974), u1974(1975), u1975(1976),
| | | u1976(1977), u1977(1978), u1978(1979), u1979(1980), u1980(1981), u1981(1982),
| | | u1982(1983), u1983(1984), u1984(1985), u1985(1986), u1986(1987), u1987(1988),
| | | u1988(1989), u1989(1990), u1990(1991), u1991(1992), u1992(1993), u1993(1994),
| | | u1994(1995), u1995(1996), u1996(1997), u1997(1998), u1998(1999), u1999(2000)
| | |
| | | +-- -R-- String outputName(2)
| | | | Textual Convention: DisplayString
| | | | Size: 1..4
| | | +-- -RW- Integer32 outputGroup(3)
| | | | Range: 1..63
| | | +-- -R-- BitString outputStatus(4)
| | | | Values: outputOn(0), outputInhibit(1), outputFailureMinSenseVoltage(2),
| | | | outputFailureMaxSenseVoltage(3), outputFailureMaxTerminalVoltage(4),
| | | | outputFailureMaxCurrent(5), outputFailureMaxTemperature(6), outputFailureMaxPower(7),
| | | | outputFailureTimeout(9), outputCurrentLimited(10), outputRampUp(11), outputRampDown(12),
| | | | outputEnableKill(13), outputEmergencyOff(14)
| | | +-- -R-- Opaque outputMeasurementSenseVoltage(5)
| | | | Textual Convention: Float
| | | | Size: 7
| | | +-- -R-- Opaque outputMeasurementTerminalVoltage(6)
| | | | Textual Convention: Float
| | | | Size: 7
| | | +-- -R-- Opaque outputMeasurementCurrent(7)
| | | | Textual Convention: Float
| | | | Size: 7
| | | +-- -R-- EnumVal outputMeasurementTemperature(8)
| | | | Values: ok(-128), failure(127)
| | | +-- -RW- EnumVal outputSwitch(9)
| | | | Values: off(0), on(1), resetEmergencyOff(2), setEmergencyOff(3), clearEvents(10)
| | | +-- -RW- Opaque outputVoltage(10)
| | | | Textual Convention: Float
| | | | Size: 7
| | | +-- -RW- Integer32 outputAdjustVoltage(11)
| | | | Range: -128..127
| | | +-- -RW- Opaque outputCurrent(12)
| | | | Textual Convention: Float
| | | | Size: 7
| | | +-- -RW- Opaque outputVoltageRiseRate(13)
| | | | Textual Convention: Float
| | | | Size: 7
| | | +-- -RW- Opaque outputVoltageFallRate(14)
| | | | Textual Convention: Float
| | | | Size: 7
| | | +-- -RW- Integer32 outputSupervisionBehavior(15)
| | | | Range: 0..65535
| | | +-- -RW- Opaque outputSupervisionMinSenseVoltage(16)
| | | | Textual Convention: Float
| | | | Size: 7
| | | +-- -RW- Opaque outputSupervisionMaxSenseVoltage(17)
| | | | Textual Convention: Float
| | | | Size: 7
| | | +-- -RW- Opaque outputSupervisionMaxTerminalVoltage(18)
| | | | Textual Convention: Float
| | | | Size: 7
| | | +-- -RW- Opaque outputSupervisionMaxCurrent(19)
| | | | Textual Convention: Float
| | | | Size: 7
| | | +-- -RW- Opaque outputConfigMaxSenseVoltage(21)
| | | | Textual Convention: Float
| | | | Size: 7

```

```

| | +-- -RW- Opaque outputConfigMaxTerminalVoltage(22)
| | | Textual Convention: Float
| | | Size: 7
| | +-- -RW- Opaque outputConfigMaxCurrent(23)
| | | Textual Convention: Float
| | | Size: 7
| | +-- -RW- Opaque outputSupervisionMaxPower(24)
| | | Textual Convention: Float
| | | Size: 7
| | +-- -RW- Opaque outputCurrentRiseRate(25)
| | | Textual Convention: Float
| | | Size: 7
| | +-- -RW- Opaque outputCurrentFallRate(26)
| | | Textual Convention: Float
| | | Size: 7
| | +-- -RW- INTEGER outputTripTimeMaxCurrent(27)
| | | Range: 0..4000
| | +-- -R-- Opaque outputHardwareLimitVoltage(28)
| | | Textual Convention: Float
| | | Size: 7
| | +-- -R-- Opaque outputHardwareLimitCurrent(29)
| | | Textual Convention: Float
| | | Size: 7
| | +-- -RW- Opaque outputConfigGainSenseVoltage(30)
| | | Textual Convention: Float
| | | Size: 7
| | +-- -RW- Opaque outputConfigOffsetSenseVoltage(31)
| | | Textual Convention: Float
| | | Size: 7
| | +-- -RW- Opaque outputConfigGainTerminalVoltage(32)
| | | Textual Convention: Float
| | | Size: 7
| | +-- -RW- Opaque outputConfigOffsetTerminalVoltage(33)
| | | Textual Convention: Float
| | | Size: 7
| | +-- -RW- Opaque outputConfigGainCurrent(34)
| | | Textual Convention: Float
| | | Size: 7
| | +-- -RW- Opaque outputConfigOffsetCurrent(35)
| | | Textual Convention: Float
| | | Size: 7
| | +-- -RW- EnumVal outputRegulationMode(38)
| | | Values: fast(0), moderate(1), slow(2)
| | +-- -RW- Integer32 outputConfigMaxTemperature(39)
| |
| +-- -R-- Integer32 groupsNumber(3)
| | Range: 1..1999
| |
| +--groupsTable(4)
| |
| | +--groupsEntry(1)
| | | Index: groupsIndex
| | |
| | +-- ---- Integer32 groupsIndex(1)
| | | Range: 0..1999
| | +-- -RW- EnumVal groupsSwitch(9)
| | | Values: undefined(-1), off(0), on(1), resetEmergencyOff(2), setEmergencyOff(3), disableKill(4),
| | | enableKill(5), clearEvents(10)
| |
| +--sensor(4)
| | +-- -R-- Integer32 sensorNumber(1)
| | | Range: 0..8
| | |
| | +--sensorTable(2)

```

```

|
| +--sensorEntry(1)
| | Index: sensorIndex
| |
| | +-- ---- EnumVal sensorIndex(1)
| | | Values: temp1(1), temp2(2), temp3(3), temp4(4), temp5(5), temp6(6), temp7(7), temp8(8)
| | +-- -R-- Integer32 sensorTemperature(2)
| | | Range: -128..127
| | +-- -RW- Integer32 sensorWarningThreshold(3)
| | | Range: 0..127
| | +-- -RW- Integer32 sensorFailureThreshold(4)
| | | Range: 0..127
| | +-- -RW- Integer32 sensorAlarmThreshold(6)
| | | Range: 0..127
|
+--communication(5)
| +--snmp(1)
| |
| | +--snmpCommunityTable(1)
| | |
| | | +--snmpCommunityEntry(1)
| | | | Index: snmpAccessRight
| | | |
| | | | +-- ---- EnumVal snmpAccessRight(1)
| | | | | Values: public(1), private(2), admin(3), guru(4)
| | | | +-- -RW- String snmpCommunityName(2)
| | | | | Size: 0..14
| | |
| | | +-- -RW- Integer32 snmpPort(2)
| | | +-- -RW- String firmwareUpdate(10)
| | | | Size: 0..30
| | | +-- -R-- IpAddr ipDynamicAddress(11)
| | | +-- -RW- IpAddr ipStaticAddress(12)
| | | +-- -RW- String macAddress(13)
| | | | Size: 6
| |
+--can(2)
| +-- -RW- Integer32 canBitRate(1)
| +-- -R-- String canReceive(2)
| | Size: 14
| +-- -RW- String canTransmit(3)
| | Size: 14
|
+--powersupply(6)
| +-- -R-- String psSerialNumber(2)
| | Textual Convention: DisplayString
| | Size: 0..255
| +-- -RW- Integer32 psOperatingTime(3)
| +-- -R-- Integer32 psAuxiliaryNumber(4)
| | Range: 0..8
|
+--psAuxiliaryTable(5)
| |
| | +--psAuxiliaryEntry(1)
| | | Index: psAuxiliaryIndex
| | |
| | | +-- ---- EnumVal psAuxiliaryIndex(1)
| | | | Values: u0(1), u1(2), u2(3), u3(4), u4(5), u5(6), u6(7), u7(8)
| | | +-- -R-- Opaque psAuxiliaryMeasurementVoltage(3)
| | | | Textual Convention: Float
| | | | Size: 7
| | | +-- -R-- Opaque psAuxiliaryMeasurementCurrent(4)
| | | | Textual Convention: Float
| | | | Size: 7

```

```

| |
| +-- -RW- String  psDirectAccess(1024)
|     Size: 1..14
|
+--fantray(7)
| +-- -RW- String  fanSerialNumber(2)
|     Textual Convention: DisplayString
|     Size: 0..14
| +-- -RW- Integer32 fanOperatingTime(3)
| +-- -R-- Integer32 fanAirTemperature(4)
| +-- -RW- Integer32 fanSwitchOffDelay(5)
|     Range: 0..900
| +-- -RW- Integer32 fanNominalSpeed(6)
| +-- -RW- Integer32 fanNumberOfFans(7)
|     Range: 0..12
|
+--fanSpeedTable(8)
| |
| | +--fanSpeedEntry(1)
| | | Index: fanNumber
| | |
| | | +-- ---- Integer32 fanNumber(1)
| | | | Range: 1..12
| | | +-- -R-- Integer32 fanSpeed(2)
| | |
| | +-- -RW- INTEGER  fanMaxSpeed(9)
| | +-- -RW- INTEGER  fanMinSpeed(10)
| | +-- -RW- Integer32 outputConfigFanMaxSpeed(11)
| | +-- -RW- Integer32 outputConfigFanMinSpeed(12)
| |
+--rack(8)
+--signal(9)
+-- -R-- Integer32 numberOfAnalogInputs(1)
|     Range: 0..8
|
+--analogInputTable(2)
| |
| | +--analogInputEntry(1)
| | | Index: analogInputIndex
| | |
| | | +-- ---- Integer32 analogInputIndex(1)
| | | | Range: 1..8
| | | +-- -R-- Opaque  analogMeasurementVoltage(2)
| | | | Textual Convention: Float
| | | | Size: 7
| | | +-- -R-- Opaque  analogMeasurementCurrent(3)
| | | | Textual Convention: Float
| | | | Size: 7
| | |
| | +-- -R-- BitString digitalInput(5)
| | | Values: d0(0), d1(1), d2(2), d3(3), d4(4), d5(5), d6(6), d7(7)
| | +-- -R-- BitString digitalOutput(6)
| | | Values: d0(0), d1(1), d2(2), d3(3), d4(4), d5(5), d6(6), d7(7)

```

## 12 MPOD Controller Firmware Update

(for Bootloader from revision 1.5 and Firmware from revision 2.\*.0.15)

1) You need the muhse control program form revision 2.0.910.0. You can download it from the wiener web site “[www.wiener-d.com](http://www.wiener-d.com)” or via the direct link “<http://www.wienerd.com/Support/MUSEcontrol/MUSEcontrolInstall-2.0.910.0.exe>”. Start the muhse control program and select the tab “system”. In the opened pull down menu select the item “Firmware Update” to update the device via USB.

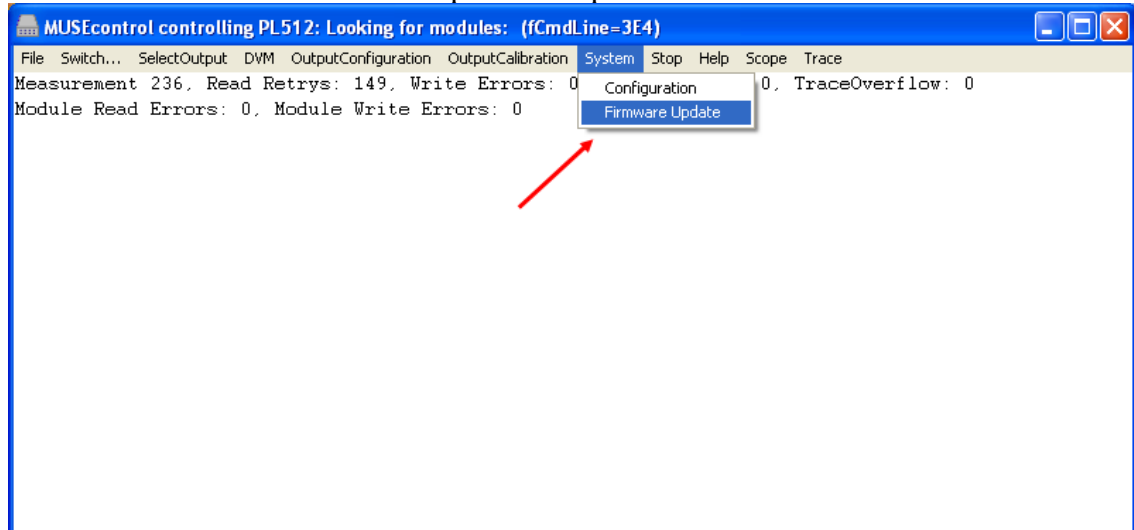

2) Hit the button “browse” to scan the device for current version of bootloader and firmware.

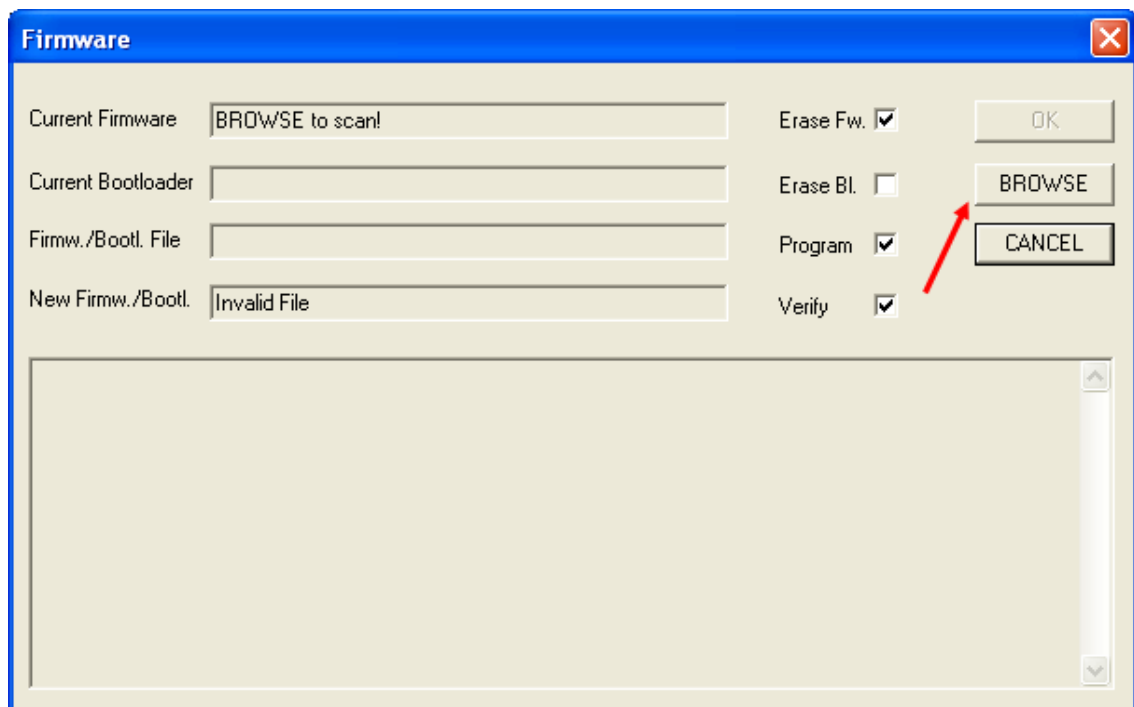

3) Check the version of the current firmware or bootloader. There are three options:

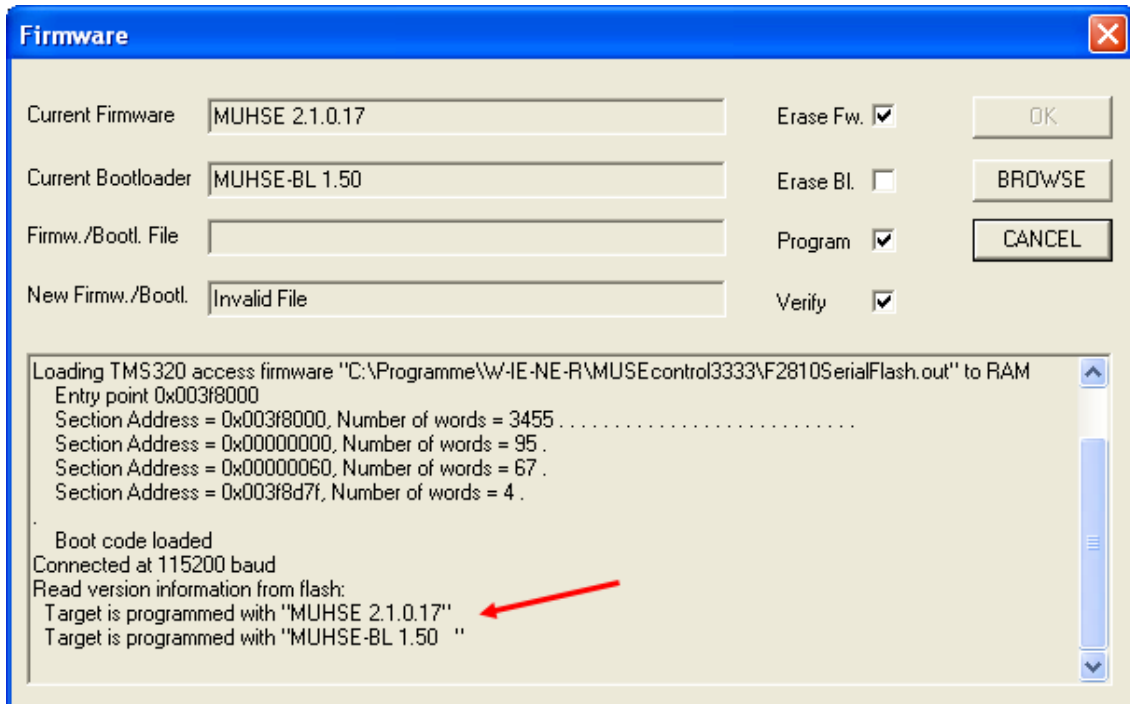

Option 1) Check “Erase Fw.” (erase firmware) and “Erase Bl.” (erase bootloader) if the current firmware is older than 2.\*.0.15 or it is a firmware without bootloader. After that push the button “browse” to scan the flash. In some minutes select the new bootloader file in the automatically opened file menu. Press the button “Ok”. Now the whole flash will be erased and the new bootloader will be installed.

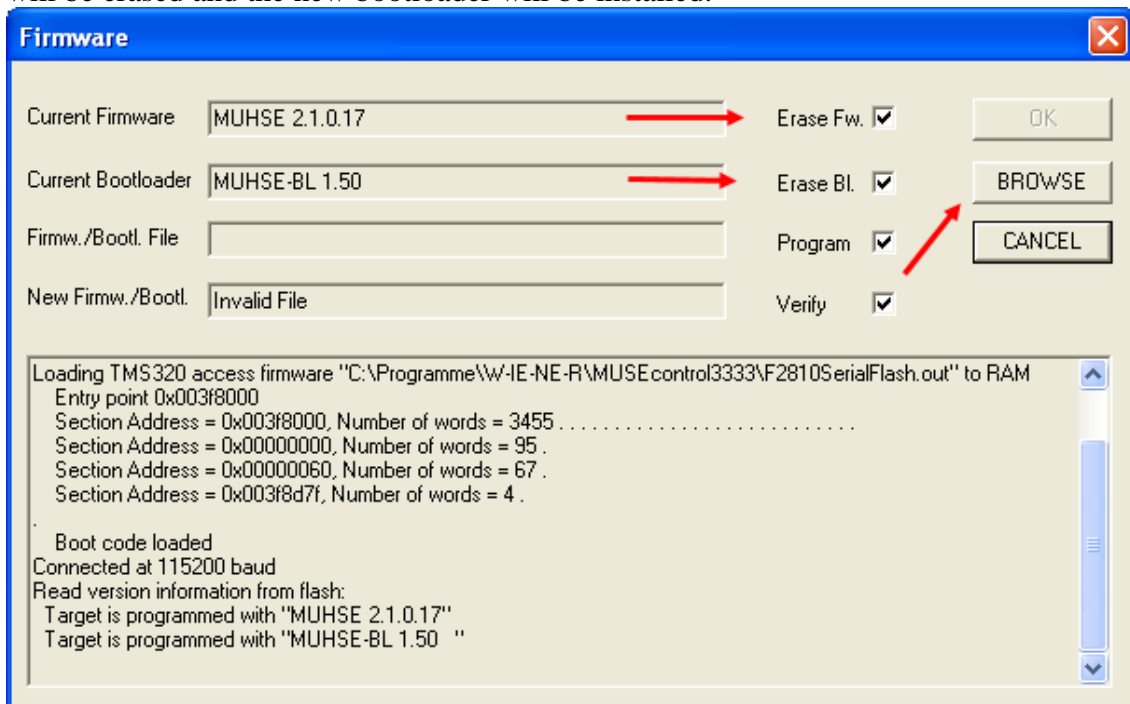

When the install process is done hit the button “cancel” to restart the system. It is recommended to close the muhse control program before restarting. A window which indicates a communication problem appears. The reason for this is that only the bootloader without firmware is installed. Ignore this message by pushing the button “cancel”.

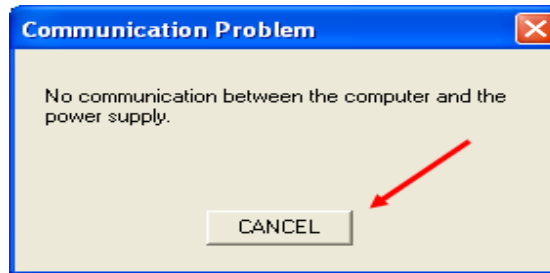

Also ignore the no modules message to hit the button “Ignorieren”.



Follow the step 1 and 2. Execute the instructions of option 2.

Option 2) Check “Erase Fw.” (erase firmware) if there no current, legal firmware is available or a newer one should be installed. After that push the button “browse” to scan the flash. In some minutes select the new firmware file in the automatically opened file menu. Press the button“Ok”. Now the firmware partition in the flash will be formatted and the new firmware will be installed.

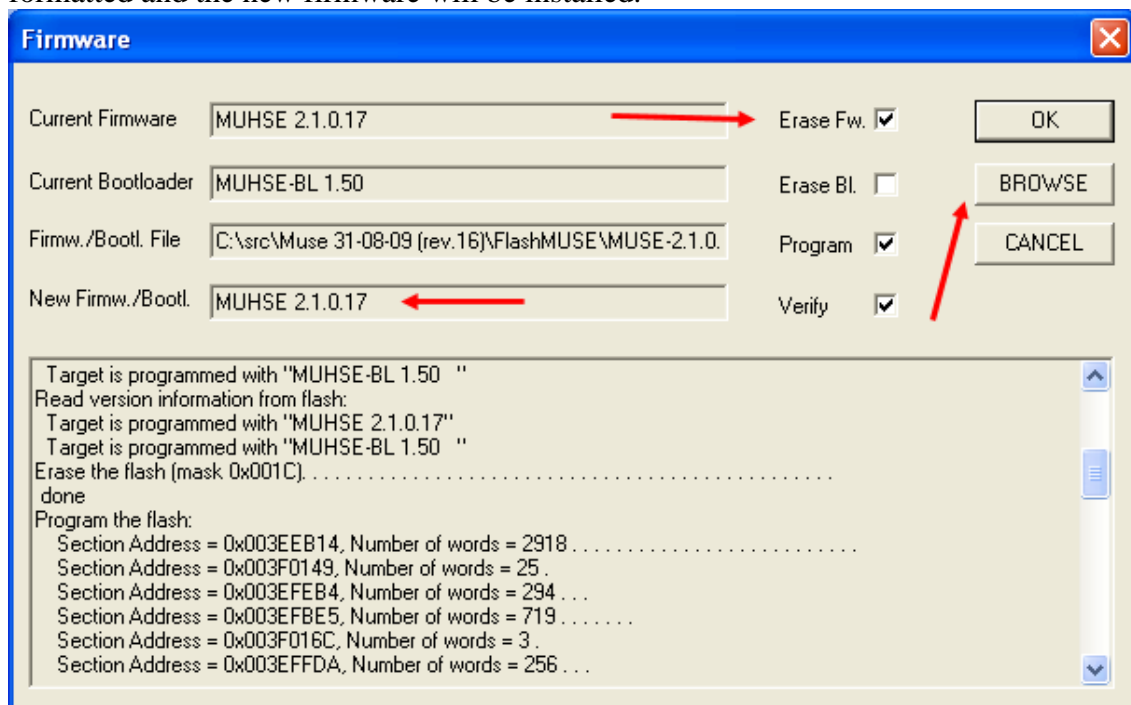

When the install process is done hit the button “cancel” to restart the system. It is recommended to close the muhse control program before restarting.

Option 3) Check “Erase Bl.” (erase bootloader) if there an older bootloader (from version 1.5) and a newer one should be installed. If no bootloader is available chose option 1. After that push the button “browse” to scan the flash. In some minutes select the new bootloader file in the automatically opened file menu. Press the button“Ok”. Now the bootloader partition in the flash will be formatted and the new bootloader will be installed.

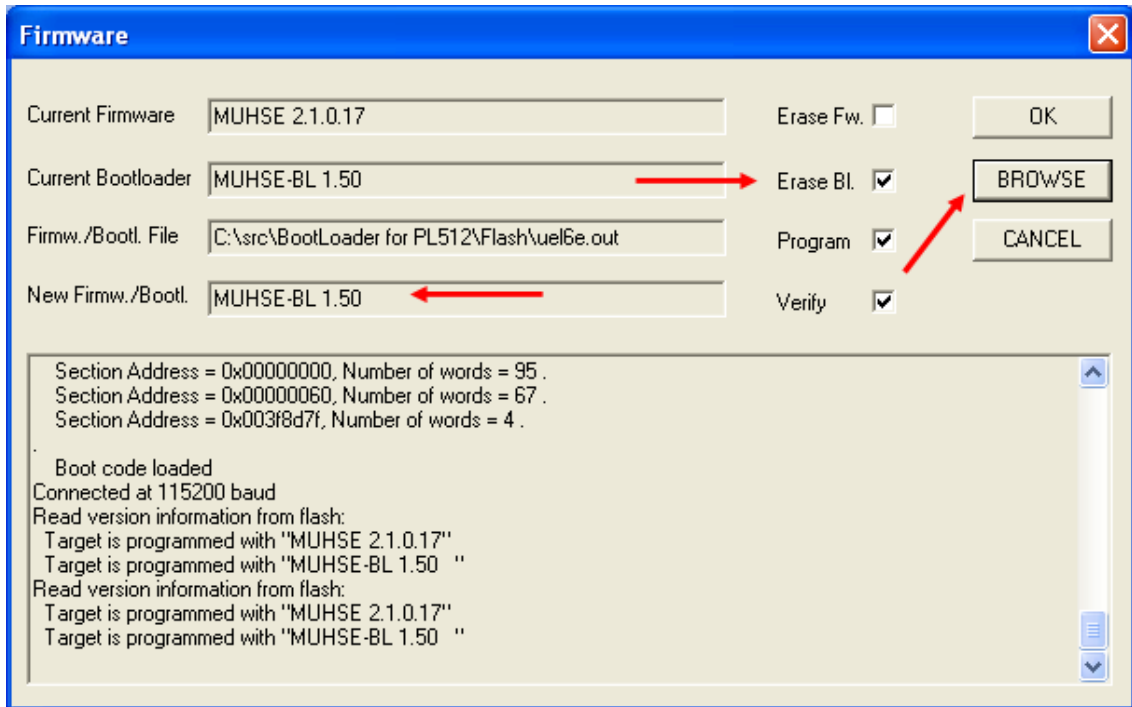

When the install process is done hit the button “cancel” to restart the system. It is recommended to close the muhse control program before restarting.



## 13 MPOD Display Firmware Update

Display firmware update is possible with all displays using firmware Doom 1.0.1344.0 or above (see <http://file.wiener-d.com/firmware/MPOD-Display>)

The update is done via Ethernet connected to the MPOD controller with the special utility PIC32PL.exe (<http://file.wiener-d.com/software/PIC32BL>)

Please install the software on your Windows PC and start the program.

**PIC32 Flash Programmer**

File Device Extras

Device Type ?  
Version ?  
Mfg ID ?  
Boot Loader ?  
Firmware ?

0%

Message

**Preferences**

Connection via IP/SNMP Search IP

Device IP Address 192.168.91.222

SNMP Timeout 400 ms

SNMP Retries 2

OK  
Cancel

Enter your IP address, and be sure the checkbox „Connect via IP/SNMP“ is checked. Then click „OK“.

Select „Extras → Preferences“

**PIC32 Flash Programmer**

File Device Extras

Device Type PIC32MX460F512L  
Version 0x509  
Mfg ID 0x053  
Boot Loader DOOM-BL 1.0.1344.0  
Firmware DOOM 1.1.2021.0

0%

Device found.

Click „Device → Connect“. The connection to the display firmware is established, and the icon changed to „Disconnect“

**PIC32 Flash Programmer**

File Device Extras

Device Type PIC32MX460F512L  
Version 0x509  
Mfg ID 0x053  
Boot Loader DOOM-BL 1.0.1344.0  
Firmware DOOM 1.1.2021.0

0%

Device found.

Now click the „Execute Boot Loader“ icon at the right. Normal operation of the display is resumed, and boot loader operation is started.

**Open HEX File**

Suchen in: output

DoomCard-2.0.2075.0.hex  
DoomCard-2.0.2072.0.hex  
DoomCard-1.1.2067. Typ: HEX-Datei  
DoomCard-1.1.2061. Geändert am: 10.12.2012 10:30  
DoomCard-2054.hex Größe: 519 KB  
DoomCard-1.1.2021.bmhex  
DoomCard.1.1.2019.0.hex  
DoomCard-1.1.1954.0.hex  
Doom-1.1.1911.0.hex

Dateiname: DoomCard-2.0.2075.0.hex Öffnen  
Dateityp: HEX files (\*.hex) Abbrechen

Now use „File → Open“

**PIC32BL**

File "C:/src/DoomCard/output/DoomCard-2.0.2075.0.hex" imported with 0 errors and 2 warnings  
min. address: 0x1d000010  
max. address: 0x1d02ff7f  
188840 bytes imported  
32 bytes ignored:  
0x1FC00000: 16 byte  
0x1FC00380: 16 byte

OK

The the new firmware is read from disk. The 2 warnings (ignored data) are correct.



Click the „Erase“ icon to erase the previous firmware.

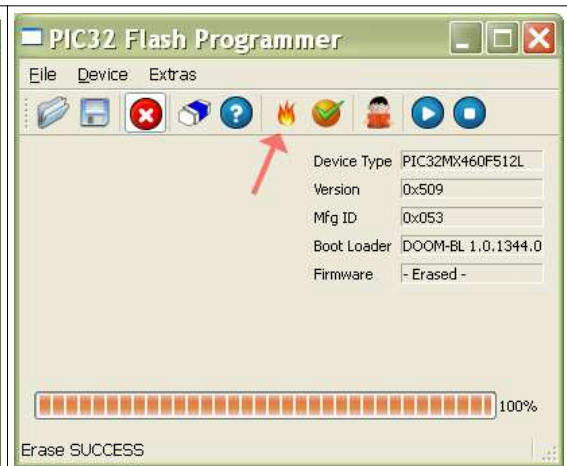

Click „Program“ to program the new firmware.

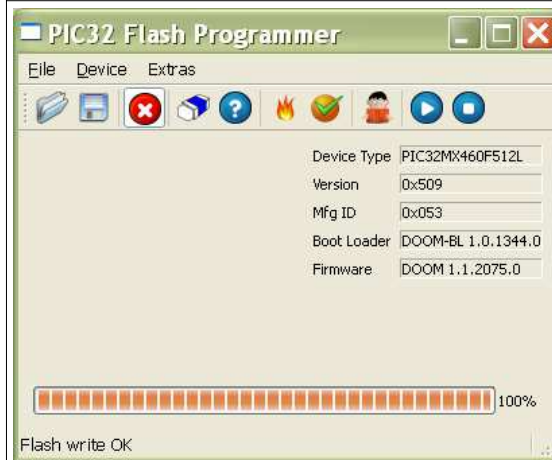

A verify is done automatically.

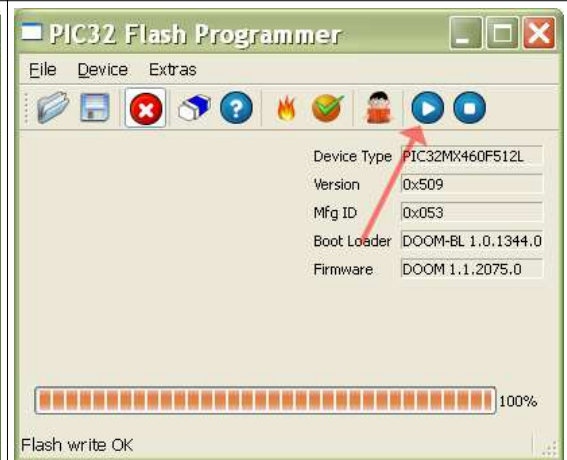

Now click the „Run new firmware“ icon to leave the boot loader and execute the new firmware.