

Tsi148™ PCI/X-to-VME Bus Bridge User Manual

Final

March 2009

80A3020_MA001_12



Trademarks

TUNDRA is a registered trademark of Tundra Semiconductor Corporation (Canada, U.S., and U.K.). TUNDRA, the Tundra logo, Tsi148, and Silicon Behind the Network, are trademarks of Tundra Semiconductor Corporation. All other registered and unregistered marks (including trademarks, service marks and logos) are the property of their respective owners. The absence of a mark identifier is not a representation that a particular product name is not a mark.

Copyright

Copyright © March 2009 Tundra Semiconductor Corporation. All rights reserved.
Published in Canada

This document contains information that is proprietary to Tundra and may be used for non-commercial purposes within your organization in support of Tundra products. No other use or transmission of all or any part of this document is permitted without written permission from Tundra, and must include all copyright and other proprietary notices. Use or transmission of all or any part of this document in violation of any applicable Canadian or other legislation is hereby expressly prohibited.

User obtains no rights in the information or in any product, process, technology or trademark which it includes or describes, and is expressly prohibited from modifying the information or creating derivative works without the express written consent of Tundra.

Disclaimer

Tundra assumes no responsibility for the accuracy or completeness of the information presented, which is subject to change without notice. Tundra products may contain design defects or errors known as errata which may cause the product to deviate from published specifications. Current characterized errata are available on request. In no event will Tundra be liable for any direct, indirect, special, incidental or consequential damages, including lost profits, lost business or lost data, resulting from the use of or reliance upon the information, whether or not Tundra has been advised of the possibility of such damages. The information contained in this document does not affect or change Tundra's product warranties.

Mention of non-Tundra products or services is for information purposes only and constitutes neither an endorsement nor a recommendation.

As this information will change over time, please ensure you have the most recent version by contacting a member of the Tundra technical support team, or by checking the Support section of www.tundra.com.

Corporate Profile

About Tundra

Tundra Semiconductor Corporation (TSX:TUN) supplies the world's leading communications, computing and storage companies with smart System Interconnect products, intellectual property (IP) and design services backed by world-class customer service and technical support. Tundra's track record of product leadership includes over a decade of bridges and switches enabling key industry standards: RapidIO®, PCI, PCI-X, PCI Express®, PowerPC®, VME, HyperTransport™, Interlaken, and SPI4.2. Tundra's products deliver high functional quality and simplified board design and layout, with specific focus on system level signal integrity. Tundra's design services division, Silicon Logic Engineering, Inc., offers industry-leading ASIC and FPGA design services, semiconductor intellectual property and product development consulting. Tundra's smart technology connects critical components in high performance embedded systems around the world.

Tundra System Interconnect

Tundra uses the term *System Interconnect* to refer to the technology used to connect all the components and sub-systems in almost any embedded system. This concept applies to the interfacing of functional elements (CPU, memory, I/O complexes) within a single-board system, and the interconnection of multiple boards in a larger system.

Advanced communications networks need advanced System Interconnect. It is a vital enabling technology for the networked world. Tundra System Interconnect provides the latest interface and throughput features, which enable communications infrastructure vendors to design and build more powerful, faster equipment in shorter timeframes.

Tundra System Interconnect — vital to building the communications systems of the future:

- Tundra System Interconnect products enable customers to get the performance, scalability, and reliability from their systems to meet today's and tomorrow's bandwidth demands.
- Tundra System Interconnect products are standards-based, off-the-shelf products that help customers speed their time to market.
- Tundra System Interconnect products meet the growing customer demand for outsourced standards-based interconnect products.

Partnerships

Fundamental to the success of Tundra is its partnerships with leading technology companies, including IBM, Intel, and Freescale. As a result of these alliances, Tundra devices complement our partners' products, and greatly influence the design of customers' architecture. Customers are changing their designs to incorporate Tundra products. This is evidence of our commitment to be a significant part of its customers' success.

Customers

Tundra Semiconductor products are used by the world's leading communications infrastructure and storage vendors, including Cisco Systems, Freescale, Siemens, Nortel Networks, Lucent Technologies, Nokia, Ericsson, Alcatel, and Hewlett-Packard.

The Tundra design philosophy is one in which a number of strategic customers are invited to participate in the definition, design, test, and early silicon phases of product development. Close working relationships with customers and clear product roadmaps ensure that Tundra can anticipate and meet the future directions and needs of communications systems designers and manufacturers.

Support

Tundra is respected throughout the industry for its outstanding commitment to customer support. Tundra ensures that its customers can take immediate advantage of the company's products through its in-house Applications Engineering Group, unmatched design support tools, and full documentation accessible through the Web.

Design. Connect. Go.[™]

Contact Information

Tundra is dedicated to providing superior technical documentation and design support to its customers. The following support options are available:

Web

Product information

The Tundra website at www.tundra.com contains the features, benefits, typical applications, and block diagram for the Tsi148. This website also allows you to register in order to receive the full suite of product information.

Technical support resources

The Support section of the Tundra website contains an extensive list of technical resources to assist with your design needs. Some of the key support resources include:

- Technical support FAQ
- User documentation
- Schematic design checklists and debug guidelines

You can also opt to receive email notification when a support resource is added or changed.

Technical support request

To contact Tundra support personnel about a technical question, fill out the Technical Support Request Form in the Support section of the website.

Sales support

The sales section of the Tundra website contains information that will help you locate a Tundra sales representative nearest you.

Mail

Tundra Semiconductor Corporation
603 March Road
Ottawa, ON, Canada
K2K 2M5

Fax

613-592-1320

Contents

Corporate Profile	3
Contact Information	5
About this Document	23
Document Conventions	23
Revision History	26
Related Information	28
1. Functional Overview	29
1.1 Overview of Tsi148	30
1.1.1 VME Renaissance	31
1.1.2 Tsi148 Features	31
1.1.3 Tsi148 Benefits	32
1.1.4 Typical Applications	32
1.2 VMEbus Interface	34
1.2.1 2eVME Protocol	34
1.2.2 2eSST Protocol	34
1.2.3 VME Slave	35
1.2.4 VME Master	36
1.2.5 Tsi148 as a VMEbus System Controller	37
1.3 PCI/X Interface	39
1.3.1 PCI/X Target	39
1.3.2 PCI/X Master	40
1.4 Linkage Module	41
1.5 Register Overview	42
1.5.1 Control and Status Registers	43
1.6 DMA Controllers	44
1.6.1 Data Movement	45

1.7	Interrupter and Interrupt Handler	45
1.8	JTAG	46
2.	VME Interface	47
2.1	Overview of the VME Interface	48
2.2	VME Slave	48
2.2.1	VME Slave Buffers.....	48
2.3	VME Master	59
2.3.1	Addressing Capabilities	59
2.3.2	VME Master Buffers	60
2.3.3	VME Master Read-Modify Write (RMW) Cycles	60
2.3.4	VME Master Bandwidth Control	62
2.3.5	VMEbus Exception Handling.....	64
2.3.6	Utility Functions.....	64
2.3.7	Tsi148 as a VMEbus System Controller.....	69
3.	PCI/X Interface	71
3.1	Overview of the PCI/X Interface	72
3.2	PCI Mode	72
3.2.1	PCI Target.....	72
3.2.2	PCI Master	83
3.2.3	PCI Bus Exception Handling	84
3.3	PCI-X Mode	86
3.3.1	PCI-X Target.....	86
3.3.2	PCI-X Master	96
3.3.3	PCI-X Bus Exception Handling	97
4.	DMA Interface	99
4.1	Overview DMA Controller	100
4.2	Architecture.....	100
4.3	DMA Buffers.....	100
4.4	Operating Modes.....	101
4.4.1	Linked-List Descriptors	102

4.5	Direction of Data Movement	104
4.5.1	PCI/X-to-VME	104
4.5.2	VME-to-PCI/X	107
4.5.3	PCI/X-to-PCI/X	110
4.5.4	VME-to-VME	113
4.5.5	Data Patterns	116
4.5.6	DMA Transaction Termination	118
4.5.7	DMA Interrupts	119
4.5.8	Transfer Throttling	119
5.	Resets, Clocks, and Power-up Options	121
5.1	Overview of Resets, Clocks, and Power-up Options	122
5.2	Resets	122
5.2.1	Reset Inputs and Outputs	123
5.2.2	Reset Timing	126
5.3	Clocks	127
5.4	Power-up Options	128
5.4.1	PCI/X Power-up Options	128
5.4.2	VMEbus Power-up Options	130
5.4.3	System Controller (SCON)	135
6.	Interrupt Controller	137
6.1	Overview of the Interrupt Controller	138
6.2	VMEbus Interrupter	138
6.3	Local Interrupter	138
6.4	VMEbus Interrupt Handler	139
7.	JTAG Module	141
7.1	Overview of JTAG	142
7.2	Instructions	142
8.	Signals and Pins	145
8.1	Overview of Signals	145
8.2	Signal Grouping	146
8.3	Signal Summary	147
8.4	Detailed Signal Descriptions	160
8.4.1	PCI/X Signal Descriptions	160
8.4.2	VMEbus Signal Descriptions	161
8.4.3	Miscellaneous Signal Descriptions	168

8.5	Pinout	171
8.5.1	Sorted by Pin Assignment	172
9.	Electrical Characteristics	185
9.1	Overview of Electrical Characteristics	186
9.1.1	PCI/X Electrical Characteristics	186
9.1.2	Non-PCI Electrical Characteristics	187
9.2	Operating Conditions	188
9.2.1	Absolute Maximum Operating Conditions	188
9.2.2	Recommended Operating Conditions	189
9.2.3	Power Supply Sequencing	189
9.3	Power Consumption	189
9.4	Thermal Characteristics	190
9.4.1	Junction-to-Ambient Thermal Characteristics (Theta ja)	190
9.4.2	Junction-to-Board and Junction-to-Case Characteristics	191
9.5	Electrostatic Discharge (ESD)	192
9.5.1	ESD Precautions	192
10.	Registers	195
10.1	Overview of Registers	196
10.2	Register Groupings	196
10.2.1	Combined Register Group (CRG)	196
10.2.2	PCI/X Configuration Space Registers (PCFS)	197
10.2.3	Local Control and Status Registers (LCSR)	197
10.2.4	Global Control and Status Registers (GCSR)	197
10.2.5	Control and Status Registers (CSR)	197
10.2.6	CR/CSR Register Access	198
10.3	Register Endian Mapping	199
10.4	Register Map	201
10.4.1	Conventions	201
10.4.2	PCFS Register Group Overview	202
10.4.3	LCSR Register Group Overview	204
10.4.4	GCSR Register Group Overview	215
10.4.5	CR/CSR Register Group Overview	216
10.4.6	PCFS Register Group Description	217
10.4.7	Vendor ID/ Device ID Registers	217
10.4.8	Command/Status Registers	218
10.4.9	Revision ID / Class Code Registers	221

10.4.10	Cache Line Size / Master Latency Timer / Header Type Registers	222
10.4.11	Memory Base Address Lower Register	224
10.4.12	Memory Base Address Upper Register	225
10.4.13	Subsystem Vendor ID/ Subsystem ID Registers	226
10.4.14	Capabilities Pointer Register	227
10.4.15	Interrupt Line/interrupt PIn/Minimum Grant/Maximum Latency Registers	228
10.4.16	PCI-X Capabilities Register	231
10.4.17	PCI-X Status Register	233
10.4.18	LCSR Register Group Description	236
10.4.19	Outbound Translation Starting Address Upper (0-7) Registers	236
10.4.20	Outbound Translation Starting Address Lower (0-7) Registers	237
10.4.21	Outbound Translation Ending Address Upper (0-7) Registers	238
10.4.22	Outbound Translation Ending Address Lower (0-7) Registers	239
10.4.23	Outbound Translation Offset Upper (0-7) Registers	240
10.4.24	Outbound Translation Offset Lower (0-7) Registers	241
10.4.25	Outbound Translation 2eSST Broadcast Select (0-7) Registers	242
10.4.26	Outbound Translation Attribute (0-7) Registers	243
10.4.27	VMEbus IACK (1-7) Registers	247
10.4.28	VMEbus Read-Modify-Write (RMW) Address Upper Register	248
10.4.29	VMEbus RMW Address Lower Register	249
10.4.30	VMEbus RMW Enable Register	250
10.4.31	VMEbus RMW Compare Register	251
10.4.32	VMEbus RMW Swap Register	252
10.4.33	VME Master Control Register	253
10.4.34	VMEbus Control Register	257
10.4.35	VMEbus Status Register	261
10.4.36	PCI/X Control / Status Register	263
10.4.37	VMEbus Filter Register	267
10.4.38	VMEbus Exception Address Upper Register	269
10.4.39	VMEbus Exception Address Lower Register	270
10.4.40	VMEbus Exception Attributes Register	271
10.4.41	Error Diagnostic PCI/X Address Upper Register	274
10.4.42	Error Diagnostic PCI/X Address Lower Register	275
10.4.43	Error Diagnostic PCI-X Attribute Register	276
10.4.44	Error Diagnostic PCI-X Split Completion Message Register	277
10.4.45	Error Diagnostic PCI/X Attributes Register	278
10.4.46	Inbound Translation Starting Address Upper (0-7) Registers	281

10.4.47	Inbound Translation Starting Address Lower (0-7) Registers	282
10.4.48	Inbound Translation Ending Address Upper (0-7) Registers	283
10.4.49	Inbound Translation Ending Address Lower (0-7) Registers	284
10.4.50	Inbound Translation Offset Upper (0-7) Registers	285
10.4.51	Inbound Translation Offset Lower (0-7) Registers	286
10.4.52	Inbound Translation Attribute (0-7) Registers	287
10.4.53	GCSR Base Address Upper Register	291
10.4.54	GCSR Base Address Lower Register	292
10.4.55	GCSR Attribute Register	293
10.4.56	CRG Base Address Upper Register	295
10.4.57	CRG Base Address Lower Register	296
10.4.58	CRG Attribute Register	297
10.4.59	CR/CSR Offset Upper Register	299
10.4.60	CR/CSR Offset Lower Register	300
10.4.61	CR/CSR Attribute Register	301
10.4.62	Location Monitor Base Address Upper Register	302
10.4.63	Location Monitor Base Address Lower Register	303
10.4.64	Location Monitor Attribute Register	304
10.4.65	64-bit Counter Upper	306
10.4.66	64-bit Counter Lower	307
10.4.67	Broadcast Pulse Generator Timer Register	308
10.4.68	Broadcast Programmable Clock Timer Register	309
10.4.69	VMEbus Interrupt Control Register	310
10.4.70	Interrupt Enable Register	313
10.4.71	Interrupt Enable Out Register	318
10.4.72	Interrupt Status Register	321
10.4.73	Interrupt Clear Register	324
10.4.74	Interrupt Map 1 Register	327
10.4.75	Interrupt Map 2 Register	329
10.4.76	DMA Control (0-1) Registers	331
10.4.77	DMA Status (0-1) Registers	336
10.4.78	DMA Current Source Address Upper (0-1) Registers	339
10.4.79	DMA Current Source Address Lower (0-1) Registers	340
10.4.80	DMA Current Destination Address Upper (0-1) Registers	341
10.4.81	DMA Current Destination Address Lower (0-1) Registers	342
10.4.82	DMA Current Link Address Upper (0-1) Registers	343
10.4.83	DMA Current Link Address Lower (0-1) Registers	344

10.4.84	DMA Source Address Upper (0-1) Registers	345
10.4.85	DMA Source Address Lower (0-1) Registers	346
10.4.86	DMA Destination Address Upper (0-1) Registers	347
10.4.87	DMA Destination Address Lower (0-1) Registers	348
10.4.88	DMA Source Attribute (0-1) Registers	349
10.4.89	DMA Destination Attribute (0-1) Registers	353
10.4.90	DMA Next Link Address Upper (0-1) Registers	357
10.4.91	DMA Next Link Address Lower (0-1) Registers	358
10.4.92	DMA Count (0-1) Registers	359
10.4.93	DMA Destination Broadcast Select (0-1) Registers	360
10.4.94	GCSR Register Group	361
10.4.95	Vendor ID / Device ID Registers	361
10.4.96	Control and Status Register	362
10.4.97	Semaphore Registers (0-3)	365
10.4.98	Semaphore Registers (4-7)	366
10.4.99	Mail Box Registers (0-3)	367
10.4.100	CR/CSR Register Group Description	368
10.4.101	CR/CSR Bit Clear Register	368
10.4.102	CR/CSR Bit Set Register	370
10.4.103	CR/CSR Base Address Register	372
A.	Typical Applications	373
A.1	Overview	373
A.2	Tsi148 Connection Schematics	374
B.	Hardware Implementation	385
B.1	Tsi148 PLL Filtering	385
B.2	Capacitance Decoupling Recommendations	386
B.3	Recommended Board Layout Guidelines	387
B.3.1	Trace Length Recommendations	387
B.3.2	Recommended Stackup	388
C.	Package Information	389
C.1	Package Characteristics	389
C.1.1	Package Notes	390
D.	Ordering Information	391
D.1	Ordering Information	391
D.2	Part Numbering	392

Bit Index	395
Index	401

List of Figures

Figure 1: Tsi148 Block Diagram	30
Figure 2: Typical Application — Tsi148 In Single Board Computer Application.	33
Figure 3: Divisions of the CRG Register Space	42
Figure 4: CR/CSR Register Space	43
Figure 5: Slave Image Programmable Address Offset	51
Figure 6: VMEbus to PCI/X Read Request	53
Figure 7: VMEbus to PCI/X Read Completion	55
Figure 8: VMEbus to PCI/X Write	57
Figure 9: Steps Used to Perform RMW Cycles on the VMEbus	62
Figure 10: PCI Target Image Programmable Address Offset.	74
Figure 11: PCI-VME Delayed Read Request	77
Figure 12: PCI-to-VME Delayed Read Completion.	79
Figure 13: PCI-to-VME Posted Write	81
Figure 14: Target Image Programmable Address Offset	88
Figure 15: PCI-X-to-VME Delayed Read Request.	90
Figure 16: PCI-X-to-VME Delayed Read Completion.	92
Figure 17: PCI-X-to-VME Posted Write	94
Figure 18: Direct Mode.	101
Figure 19: Linked-list Mode	102
Figure 20: DMA Transaction: PCI/X-to-VME Request.	105
Figure 21: DMA Transaction: PCI/X-to-VME Completion.	106
Figure 22: DMA Transaction: VME-to-PCI/X Request.	108
Figure 23: DMA Transaction: VME-to-PCI/X Completion.	109
Figure 24: DMA Transaction: PCI/X-to-PCI/X Request	111
Figure 25: DMA Transaction: PCI/X-to-PCI/X Completion	112

Figure 26: DMA Transaction: VME-to-VME Request	114
Figure 27: DMA Transaction: VME-to-VME Completion	115
Figure 28: 8-bit Pattern Writes	116
Figure 29: 32-bit Pattern Writes	117
Figure 30: Tsi148 Reset Structure	122
Figure 31: Timing for Power-up Reset	126
Figure 32: JTAG Functional Diagram	142
Figure 33: Signal Grouping	146
Figure 34: Pinout — Bottom View	171
Figure 35: Combined Register Group (CRG)	196
Figure 36: CR/CSR Address Space	198
Figure 37: Big to Little Endian Data Swap	199
Figure 38: Tsi148 Schematic (Page 38) - Tsi148 Device	375
Figure 39: Tsi148 Schematic (Page 39) - Power Pins	376
Figure 40: Tsi148 Schematic (Page 40) - Pull-up and Pull-down Requirements	377
Figure 41: Tsi148 Schematic (Page 41) - VME Data Buffers	378
Figure 42: Tsi148 Schematic (Page 42) - VME Address Buffers	379
Figure 43: Tsi148 Schematic (Page 43) - VME Control Buffers	380
Figure 44: Tsi148 Schematic (Page 44) - VME Transceivers	381
Figure 45: Tsi148 Schematic (Page 45) - VME Transceivers	382
Figure 46: Tsi148 Schematic (Page 56) - PCI Bus 0.0 and 1.0 Pull-ups	383
Figure 47: Tsi148 Schematic (Page 58) - PCI Bus 0.0 Configuration Header	384
Figure 48: Recommended PLL Filter	385
Figure 49: Tsi148 PBGA Orientation	387
Figure 50: 456-Pin PBGA Package Diagram — Bottom and Side Views	390
Figure 51: 456-Pin PBGA Package Diagram — Top and Side View	390

List of Tables

Table 1:	VMEbus Address Mode Codes	59
Table 2:	Location Monitor Interrupt Addresses	66
Table 3:	PCI Read Data Size	76
Table 4:	DMA Controller Linked-List Descriptors	102
Table 5:	PCI Bus Configuration	127
Table 6:	PCI/X Bus Configuration	129
Table 7:	VMEbus Power-up Options	130
Table 8:	ASIDEN and GSIDEN Definition.	131
Table 9:	CR/CSR Base Address Configuration.	131
Table 10:	VMEbus System Controller Configuration.	135
Table 11:	Signal Conventions - I/O Type.	147
Table 12:	Signal Conventions - I/O Level.	147
Table 13:	Signal Conventions - I/O Drive.	148
Table 14:	Pin List.	148
Table 15:	VMEbus Signal Descriptions	161
Table 16:	Miscellaneous Signal Descriptions	168
Table 17:	Pinout — Sorted by Pin Assignment.	172
Table 18:	VSS (Ground) — Sorted by Pin Assignment	179
Table 19:	Core Power (1.8 V) — Sorted by Pin Assignment	182
Table 20:	I/O Power (3.3 V) — Sorted by Pin Assignment	183
Table 21:	PCI/X Electrical Characteristics	186
Table 22:	3.3 V LVTTTL DC Electrical Characteristics.	187
Table 23:	5.0 V LVTTTL DC Electrical Characteristics.	187
Table 24:	Common Receiver DC Electrical Characteristics.	187
Table 25:	LVTTTL Driver DC Electrical Characteristics	187

Table 26: 1.8 V CMOS Driver DC Electrical Characteristics	188
Table 27: Absolute Maximum Ratings	188
Table 28: Recommended Operating Conditions	189
Table 29: Tsi148 Total Power Dissipation (Core + IO).	189
Table 30: Tsi148 Power Dissipation Division	190
Table 31: 456 EPBGA Package Thermal Performance for an 8 layer PCB	191
Table 32: 456 EPBGA Package Thermal Performance for a 4 layer PCB	191
Table 33: Thermal Characteristics of Tsi148.	191
Table 34: Tsi148 ESD Classification.	192
Table 35: Endian Register Views.	200
Table 36: PCFS Register Group.	202
Table 37: LCSR Register Group	204
Table 38: GCSR Register Group	215
Table 39: CR/CSR Register Group	216
Table 40: Vendor ID/ Device ID Registers	217
Table 41: Command/Status Register	218
Table 42: Revision ID / Class Code Register.	221
Table 43: Cache Line Size / Master Latency Timer / Header Type Register	222
Table 44: Memory Base Address Lower Register	224
Table 45: Memory Base Address Upper Register	225
Table 46: Subsystem Vendor ID/ Subsystem ID Register.	226
Table 47: Capabilities Pointer Register	227
Table 48: Interrupt Line/Interrupt PIn/Minimum Grant/Maximum Latency Register	228
Table 49: CRG Space Type	229
Table 50: INTP INTx Encoding.	229
Table 51: PCI-X Capabilities Register.	231
Table 52: MOST Encoding	232
Table 53: MMRBC Encoding	232
Table 54: PCI-X Status Register	233
Table 55: DMCRS Encoding	234
Table 56: Outbound Translation Starting Address Upper (0-7) Register	236
Table 57: Outbound Translation Starting Address Lower (0-7) Register	237
Table 58: Outbound Translation Ending Address Upper (0-7) Register	238

Table 59: Outbound Translation Ending Address Lower (0-7) Register	239
Table 60: Outbound Translation Offset Upper (0-7) Register.	240
Table 61: Outbound Translation Offset Lower (0-7) Register	241
Table 62: Outbound Translation 2eSST Broadcast Select (0-7) Register	242
Table 63: Outbound Translation Attribute (0-7) Register	243
Table 64: Prefetch Size	244
Table 65: 2eSST Transfer Rate	245
Table 66: VMEbus Transfer Mode	245
Table 67: VMEbus Data Bus Width	245
Table 68: VMEbus Address Mode	246
Table 69: VMEbus IACK (1-7) Register.	247
Table 70: VMEbus RMW Address Upper Register	248
Table 71: VMEbus RMW Address Lower Register	249
Table 72: VMEbus RMW Enable Register	250
Table 73: VMEbus RMW Compare Register	251
Table 74: VMEbus RMW Swap Register	252
Table 75: VME Master Control Register.	253
Table 76: VME Master Time Off	255
Table 77: VME Master Time On.	255
Table 78: VME Master Release Mode	256
Table 79: VMEbus Control Register.	257
Table 80: Deadlock Timer	258
Table 81: VMEbus Global Time-out.	259
Table 82: VMEbus Status Register	261
Table 83: PCI/X Control / Status Register	263
Table 84: PCI-X Split Read Time-out.	264
Table 85: PCI/X Control / Status Register	267
Table 86: Acknowledge Delay Time.	268
Table 87: VMEbus Exception Address Upper Register	269
Table 88: VMEbus Exception Address Lower Register	270
Table 89: VMEbus Exception Attributes Register	271
Table 90: Error Diagnostic PCI/X Address Upper Register	274
Table 91: Error Diagnostic PCI/X Address Lower Register	275

Table 92: Error Diagnostic PCI-X Attribute Register	276
Table 93: Error Diagnostic PCI-X Split Completion Message Register	277
Table 94: Error Diagnostic PCI/X Attributes Register	278
Table 95: Inbound Translation Starting Address Upper (0-7) Register	281
Table 96: Inbound Translation Starting Address Upper (0-7) Register	282
Table 97: Inbound Translation Ending Address Upper (0-7) Register	283
Table 98: Inbound Translation Ending Address Lower (0-7) Register	284
Table 99: Inbound Translation Offset Upper (0-7) Register	285
Table 100: Inbound Translation Offset Lower (0-7) Register	286
Table 101: Inbound Translation Attribute (0-7) Register	287
Table 102: Virtual FIFO Size	288
Table 103: 2eSST Mode	289
Table 104: VMEbus Address Space	289
Table 105: GCSR Base Address Upper Register	291
Table 106: GCSR Base Address Lower (0-7) Register	292
Table 107: GCSR Attribute Register	293
Table 108: VMEbus Address Space	294
Table 109: CRG Base Address Upper Register	295
Table 110: CRG Base Address Lower Register	296
Table 111: CRG Attribute Register	297
Table 112: VMEbus Address Space	298
Table 113: CR/CSR Offset Upper Register	299
Table 114: CR/CSR Offset Lower Register	300
Table 115: CRG Attribute Register	301
Table 116: Location Monitor Base Address Upper Register	302
Table 117: Location Monitor Base Address Lower Register	303
Table 118: Location Monitor Register	304
Table 119: VMEbus Address Space	305
Table 120: 64-bit Counter Upper Register	306
Table 121: 64-bit Counter Lower Register	307
Table 122: Broadcast Pulse Generator Timer Register	308
Table 123: Broadcast Programmable Clock Timer Register	309
Table 124: VMEbus Interrupt Control Register	310

Table 125: Counter Source	311
Table 126: Edge Interrupt Source	311
Table 127: VMEbus IRQ[1]O Function	311
Table 128: VMEbus IRQ[2]O Function	312
Table 129: Interrupt Enable Register	313
Table 130: Interrupt Enable Out Register	318
Table 131: Interrupt Status Register	321
Table 132: Interrupt Clear Register	324
Table 133: Interrupt Map 1 Register	327
Table 134: Interrupt Map 2 Register	329
Table 135: DMA Control (0-1) Register	331
Table 136: DCTL BKS Encoding	333
Table 137: DCTL VBOT Encoding	334
Table 138: DCTL PBKS Encoding	334
Table 139: DCTL PBOT Encoding	335
Table 140: DMA Status (0-1) Register	336
Table 141: DSTA ERT Encoding	338
Table 142: DMA Current Source Address Upper (0-1) Register	339
Table 143: DMA Current Source Address Lower (0-1) Register	340
Table 144: DMA Current Destination Address Upper (0-1) Register	341
Table 145: DMA Current Destination Address Lower (0-1) Register	342
Table 146: DMA Current Link Address Upper (0-1) Register	343
Table 147: DMA Current Link Address Lower (0-1) Register	344
Table 148: DMA Source Address Upper (0-1) Register	345
Table 149: DMA Source Address Lower (0-1) Register	346
Table 150: DMA Destination Address Upper (0-1) Register	347
Table 151: DMA Destination Address Lower (0-1) Register	348
Table 152: DMA Source Attribute (0-1) Register	349
Table 153: DSAT TYP Encoding	350
Table 154: 2eSST Transfer Rate	351
Table 155: VMEbus Transfer Mode	351
Table 156: VMEbus Data Bus Width	351
Table 157: VMEbus Address Mode	352

Table 158: DMA Destination Attribute (0-1) Register	353
Table 159: DDAT TYP Encoding	354
Table 160: 2eSST Transfer Rate	354
Table 161: VMEbus Transfer Mode	355
Table 162: VMEbus Data Bus Width	355
Table 163: VMEbus Address Mode	356
Table 164: DMA Next Link Address Upper (0-1) Register	357
Table 165: DMA Next Link Address Lower (0-1) Register	358
Table 166: DMA Count (0-1) Register	359
Table 167: DMA Destination Broadcast Select (0-1) Register	360
Table 168: Vendor ID / Device ID Register	361
Table 169: Control and Status Register	362
Table 170: Semaphore Register (0-3)	365
Table 171: Semaphore Registers (0-4)	366
Table 172: Mail Box Registers (0-3)	367
Table 173: CR/CSR Bit Clear Register	368
Table 174: CR/CSR Bit Set Register	370
Table 175: CR/CSR Base Address Register	372
Table 176: Package Characteristics	389
Table 177: Ordering Information	391

About this Document

This chapter discusses general document information about the Tsi148 PCI/X-to-VME Bus Bridge User Manual. The following topics are described:

- “Document Conventions” on page 23
- “Revision History” on page 26
- “Related Information” on page 28

Document Conventions

This section explains the document conventions used in this manual.

Non-differential Signal Notation

Non-differential signals, such as those used by the PCI/X standard, are either active high or active low. Active low signals are defined as true (asserted) when they are at a logic low. Similarly, active high signals are defined as true at a logic high. Non-differential signals are considered asserted when active and negated when inactive, irrespective of voltage levels. For voltage levels, the use of 0 indicates a low voltage while a 1 indicates a high voltage.

Non-differential signals that assume a logic low state when asserted are followed by an underscore sign as the last non-numerical character, “_”. For example, SIGNAL_[0] is asserted low to indicate an active low signal. Non-differential signals not followed by an underscore are asserted when they assume the logic high state. For example, SIGNAL[0] is asserted high to indicate an active high signal.

Bit Ordering Notation

When referring to PCI/X transactions, this document assumes the most significant bit is the largest number (also known as *little-endian* bit ordering). For example, the PCI address/data bus consists of AD[31:0], where AD[31] is the most significant bit and AD[0] is the least-significant bit of the field.

Both bits and bytes have an ordering convention. The bit ordering convention for the PCI bus interface is little-endian bit ordering in which bit 0 is the least significant bit. The byte ordering convention of the PCI bus is little-endian. Byte 0 represents the least significant data bits of the word. This corresponds to the bit and byte ordering convention of the PCI bus. PCI is consistent in the bit and byte ordering.

The bit ordering convention for the VMEbus interface is little-endian bit ordering in which bit 0 is the least significant bit. The byte ordering convention is big-endian. Byte 0 represents the most significant bits of the word. This corresponds to the bit and byte ordering convention of the VMEbus. The VMEbus is not consistent in the bit and byte ordering.

Object Size Notation

The following object size conventions are used for PCI/X transactions:

- A *byte* is an 8-bit object.
- A *word* is a 16-bit (2-byte) object.
- A *doubleword* (dword) is a 32-bit (4-byte) object.
- A *quadword* is a 64-bit (8-byte) object.

Numeric Notation

The following numeric conventions are used:

- Hexadecimal numbers are denoted by the prefix *0x*. For example, 0x04.
- Binary numbers are denoted by the suffix *b*. For example, 10b.

Typographic Notation

The following italic typographic conventions are used in this manual:

- Book titles: For example, *PCI Local Bus Specification (Revision 2.2)*.
- Important terms: For example, when a device is granted access to the PCI bus it is called the *bus master*.
- Undefined values: For example, the device supports four channels depending on the setting of the PCI_Dx register.

Terminology

The following terms are used in this manual:

- **PCI/X**: Refers to both the PCI and PCI-X bus. The PCI/X interface can be configured for either PCI or PCI-X operation.

Symbols Used

The following symbols are used in this manual:



This symbol indicates important configuration information or suggestions.



This symbol indicates procedures or operating levels that may result in misuse or damage to the device.



This symbol indicates a basic design concept or information considered helpful.

Revision History

80A3020_MA001_12, Final, January

This revision of the Tsi148 PCI/X-to-VME Bus Bridge User Manual has the following change:

- The functionality of the SRESET bit was clarified in “Reset Inputs and Outputs” on page 123 and “VMEbus Control Register” on page 257
- “Power Supply Sequencing” on page 189 was updated

80A3020_MA001_11, Final, August 2008

This revision of the Tsi148 PCI/X-to-VME Bus Bridge User Manual has the following change:

- The “Junction-to-Board and Junction-to-Case Characteristics” on page 191 information was added

80A3020_MA001_10, Final, April 2008

This revision of the Tsi148 PCI/X-to-VME Bus Bridge User Manual has the following change:

- Clarifications have been made to “Resets, Clocks, and Power-up Options” on page 121
- The TRST_ signal information was updated in “Resets, Clocks, and Power-up Options” on page 121 and “Detailed Signal Descriptions” on page 160

80A3020_MA001_09, Final, January 2008

This revision of the Tsi148 PCI/X-to-VME Bus Bridge User Manual has the following changes:

- Clarifications have been made to “Resets, Clocks, and Power-up Options” on page 121.
- “Ordering Information” on page 391 was updated to include industrial variants.

80A3020_MA001_08, Final, September 2006

This revision of the Tsi148 PCI/X-to-VME Bus Bridge User Manual had the following changes:

- The reset value for the SELTIM0 bit in the “Command/Status Registers” on page 218 was changed from 0 to 1.
- The mechanical outline drawing in the “Package Information” on page 389 chapter was updated.

80A3020_MA001_07, Final, March 2006

This revision of the Tsi148 PCI/X-to-VME Bus Bridge User Manual had the following changes:

- The PERRM field in the Interrupt Map 2 Register had the function description corrected from DMA0 Interrupt Map to the PCI/X Bus Error Interrupt Map (see Section 10.4.75 on page 329).
- The naming NIP bit in the DMA Source Attribute (0-1) Registers was corrected. It was previously called the NIN bit (see Section 10.4.88 on page 349). Table 153 on page 350 was also corrected to reflect the correct NIP data pattern.
- The lead free commercial part number was added to the Ordering Information chapter (see Section D. on page 391).

Related Information

The following information is useful for reference purposes when using this manual:

<i>American National Standard for VME64</i>	This specification defines the VME64 hardware system including the protocol, electrical, mechanical and configuration specification for the VMEbus components and expansion boards.
<i>American National Standard for VME64 Extensions (ANSI/VITA 6.1 1996 (R2003))</i>	This specification defines extensions to the VME64 standard including the protocol, electrical, mechanical and configuration specification for the VMEbus components and expansion boards.
<i>Source Synchronous Transfer (2eSST) Standard (VITA 1.5 2003)</i>	This specification defines the 2eSST including the protocol, electrical, and configuration specifications.
<i>PCI Local Bus Specification (Revision 2.2)</i>	This specification defines the PCI hardware system including the protocol, electrical, mechanical and configuration specification for the PCI local bus components and expansion boards. For more information, see www.pcisig.com .
<i>PCI-X Addendum to PCI Local Bus Specification (Revision 1.0b)</i>	This specification addresses the need for increased bandwidth of PCI Devices. PCI-X enables the design of systems and devices that can operate at speeds significantly higher than today's specification allows. For more information, see www.pcisig.com .

1. Functional Overview

This chapter describes the main features and functions of the Tsi148™. The following topics are discussed:

- “Overview of Tsi148” on page 30
- “Tsi148 Features” on page 31
- “Tsi148 Benefits” on page 32
- “Typical Applications” on page 32
- “VMEbus Interface” on page 34
- “PCI/X Interface” on page 39
- “Linkage Module” on page 41
- “Register Overview” on page 42
- “DMA Controllers” on page 44
- “Interrupter and Interrupt Handler” on page 45
- “JTAG” on page 46

1.1 Overview of Tsi148

The Tundra Tsi148 device is the next generation component in our industry leading, high performance VMEbus system interconnect product family. Tsi148 is fully compliant with the 2eSST and VME64 Extension standards. This enables you to take advantage of the higher performance VME protocols, while preserving your existing investment in VME boards that implement legacy protocols.

Tsi148 increases a system’s usable bus bandwidth because its local bus interface is designed for the next generation PCI/X processors and peripherals that support either a 66 MHz PCI bus or a 133 MHz PCI-X bus interface.

Tsi148 eases design constraints of VME Single Board Computers (SBCs) by requiring less board real estate and power than the previous generation of VME-to-PCI/X bridge components.

These capabilities make Tsi148 a key building block of the VME Renaissance and the development of next generation VME single board computers.

Figure 1: Tsi148 Block Diagram

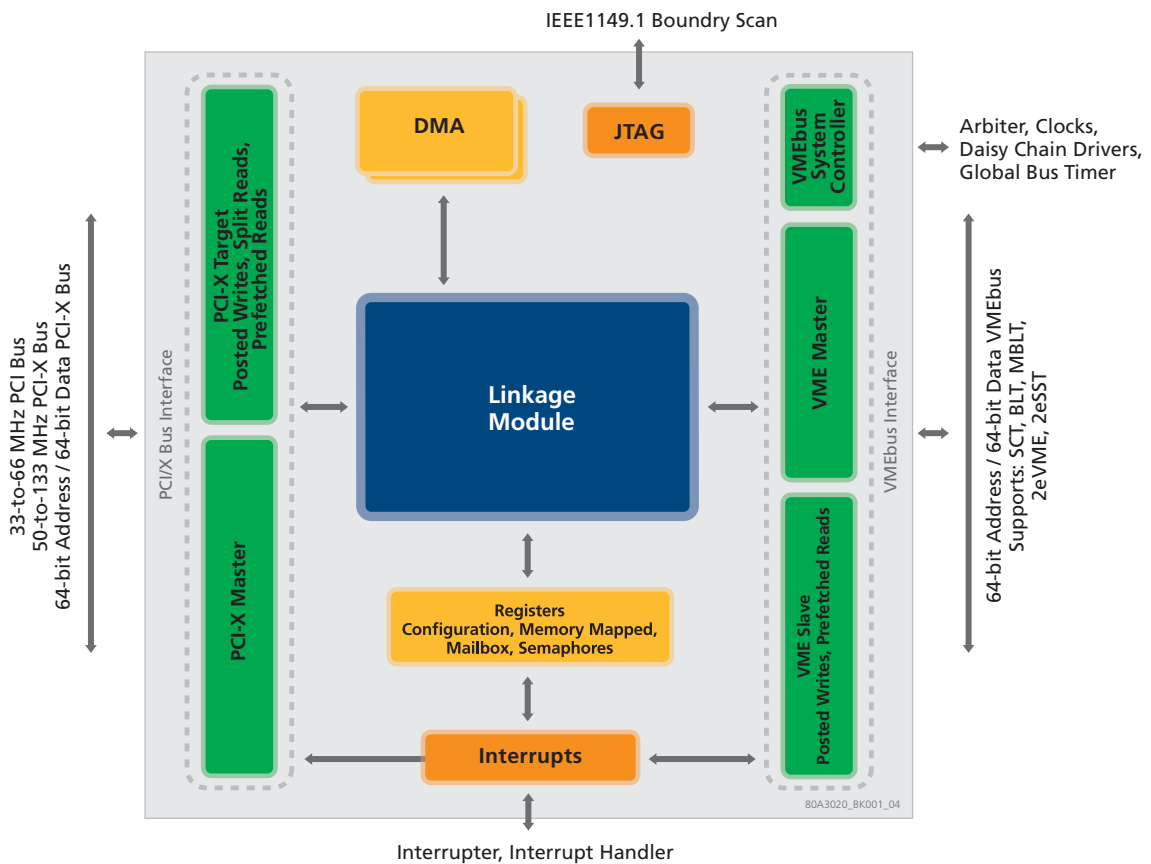

1.1.1 VME Renaissance

VME Renaissance is a term defined by Motorola™ that describes an intense period of intellectual activity and technology infusion focused on the VMEbus. The renaissance is a period of innovation and performance improvement which maintains backwards compatibility to legacy VMEbus standards. This compatibility requirement protects existing customer investments.

The VME Renaissance gives VME a faster parallel backplane interconnect, a switched serial interconnect on the backplane coincident with the traditional parallel interconnect, point-to-point mezzanines on the cards and many other significant innovations.

1.1.2 Tsi148 Features

Tsi148 has the following key features:

VMEbus Interface

- Standards supported:
 - Legacy protocols to protect existing VME investment
 - VME64 Extensions
 - 2eVME and 2eSST protocols to bring support for higher bandwidth
- Full VMEbus system controller functionality

PCI/X Interface

- Fully compliant, programmable PCI or PCI-X bus interface
- Multiple modes of bus operation
 - Interface can be configured as PCI-X or PCI
 - PCI-X interface operates from 50-to-133 MHz
 - PCI interface operates from 33-to-66 MHz
- 32-bit or 64-bit addressing and data in PCI and PCI-X modes

Other Features

- Two, programmable DMA controllers with Direct mode and Linked-List mode support
- Interrupt and interrupt handling capability
- Flexible register set; programmable from both PCI/X and VMEbus
- IEEE 1149.1 Interface
- 456 PBGA package, 1.0 mm ball pitch

1.1.3 Tsi148 Benefits

Tsi148 offers the following benefits to designers:

- Increased bandwidth
 - 8x increase in usable system bus bandwidth over current solutions
- Less power required than existing devices due to reduced voltages
 - 3.3V I/O supply
 - 1.8V Core supply
- Small device footprint
 - 40% less space required than existing products
- Reliable customer support with experience supporting the VME community for the past decade.

1.1.4 Typical Applications

Tsi148 is intended for VME Single Board Computers and VME I/O peripheral cards that serve the following markets:

- Telecommunications
- Industrial automation
- Medical
- Military
- Aerospace

1.1.4.1 Typical Application — Single Board Computers

The Tsi148 can be used on VME-based Single Board Computers (SBC) that employ PCI/X as their local bus and VME as the backplane bus, as shown in the accompanying diagram. These SBC cards support a variety of applications including telecommunications, datacommunications, medical, industrial automation, and military equipment.

The Tsi148 high performance architecture seamlessly bridges the PCI/X and VME busses, and is the VME industry's standard for single board computer interconnect device.

Figure 2: Typical Application — Tsi148 In Single Board Computer Application

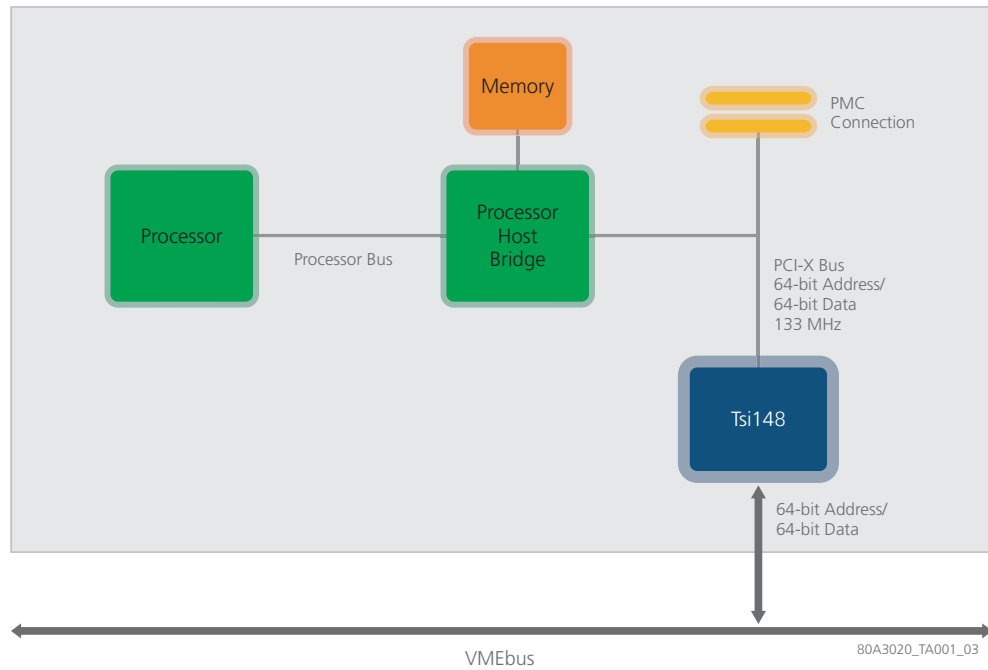

1.2 VMEbus Interface

The Tsi148 VMEbus Interface is compliant with the following standards:

- *American National Standard for VME64 (ANSI/VITA 1.0 - 1994 (R2002))*
- *American National Standard for VME64 Extensions (ANSI/VITA 1.1 - 1997)*
- *Source Synchronous Transfer (2eSST) Standard*

For more information on the VME Interface refer to [Section 2. on page 47](#).

1.2.1 2eVME Protocol

The 2eVME protocol doubles the VME64 peak block data rate to 160 Mbytes/s by utilizing both edges of the DS* signal and the DTACK signal to validate data. The addressing phase of the transaction also differs from VME64 transactions because the address broadcast is split into three phases. The three phase address broadcast transmits extended AM codes (programmable limit of 256 codes), VME master information, and the transaction beat count.

The 2eVME protocol doubles peak block data rate and has flexibility in transaction terminations. The following terminations of transactions are allowed in 2eVME:

- Master termination: Before the beat count expires
- Slave terminated transactions: Using the RETRY* and BERR* signals
- Slave suspended terminations: Using the RETRY* and DTACK* signals

Refer to the *American National Standard for VME64 Extensions* for more information on the 2eVME protocol.

1.2.2 2eSST Protocol

The 2eSST protocol further increases VME transaction bandwidth with programmable transfer rates of 160, 267, and 320 Mbytes/s.

Although the 2eSST protocol is similar to the 2eVME protocol there are a number of differences and specific requirements for 2eSST protocol. Transactions are source synchronous in 2eSST; there is no acknowledgement from receiver of the data. This lack of acknowledgement enables transactions to happen at a faster rate; there are no delays caused by multiple acknowledgments as in the original VME standard.

Performance enhancements delivered by 2eSST require careful management of system-wide skew. 2eSST protocol implementation is possible on standard VME64x five row backplanes with Texas Instrument's high performance bus transceivers

Refer to the *Source Synchronous Transfer (2eSST) Standard* for more information on the 2eSST protocol.

1.2.3 VME Slave

The Tsi148 VME Slave accepts most of the addressing and data transfer modes documented in the *VME64 Specification*, the *VME64x Specification*, and *Source Synchronous Transfer (2eSST) Standard* specification. The supported transactions include:

- Address: A16, A24, A32, and A64
- Data: D8, D16, and D32 Single Cycle Transaction (SCT)
- Data: D8, D16, D32 Block Transaction (BLT)
- Data: D64 Multiple Block Transaction (MBLT)
- Data: D64 2eVME
- Data: D64 2eSST

Incoming write transactions from the VMEbus are posted. With posted write transactions, data is written to a VME Slave write buffer. The VME Slave write buffer is a 4 Kbyte buffer. When the Tsi148 VME Slave accepts a write request, the initiating VMEbus master receives a data acknowledgment from Tsi148. Write data is transferred from the VME Slave write buffer, through the internal Linkage Module, to the PCI/X Master write buffer without involving the initiating VMEbus master. Refer to [Section 2.2.1 on page 48](#) for a detailed description of transaction flow and buffer usage in Tsi148.

The VME Slave read operations depend on whether the transfer is a SCT or BLT transfer. If the transfer is a SCT transfer, the VME Slave requests a single beat transfer from the Linkage Module (see [Section 1.4 on page 41](#)). A PCI/X prefetched read is initiated when a VMEbus master initiates a block read (BLT, MBLT, 2eVME, or 2eSST) transaction on the VMEbus. When the Tsi148 PCI/X Master receives a read request (after the VME Slave sends the read request requirements through the Linkage Module), the PCI/X Master fills its read buffer by issuing burst requests to the PCI/X bus target.

The VME Slave read buffer is a 2 Kbyte read buffer with a programmable size and refill threshold. The design enables the initiating VMEbus master to acquire its block read data from the VME Slave (after the PCI/X Master has transferred the data through the Linkage Module to the VME Slave) instead of directly from the PCI/X resources. Refer to [Section 2.5 on page 79](#) for a detailed description of transaction flow and buffer usage in Tsi148.

1.2.3.1 Features Not Supported

The following features are not supported by the Tsi148 VME Slave:

- A40 address modes
- D32 MBLT transfers
- VMEbus Lock commands
- RMW cycles are not guaranteed indivisible on the PCI bus

1.2.4 VME Master

The Tsi148 is VME Master when the VME Master is internally requested by the Linkage Module to service the PCI/X Target, DMA, or Interrupts. The internal Linkage Module arbitrates requests for each interface. Refer to [Section 1.4 on page 41](#) for more information on the Linkage Module.

The Tsi148's VME Master can generate the following addressing and data transfer modes:

- Address: A16, A24, A32, and A64
- Data: D8, D16, and D32 Single Cycle Transaction (SCT)
- Data: D16, D32 Block Transaction (BLT)
- Data: D64 Multiple Block Transaction (MBLT)
- Data: D64 2eVME
- Data: D64 2eSST

As VME Master, Tsi148 supports Read-Modify-Write (RMW) generation, and RETRY* as a termination from the external VMEbus slave.



Refer to the *American National Standard for VME64 Extensions* for more information on the RETRY* signal.

The VME Master has two 4 Kbyte posted write buffers and two 4 Kbyte prefetch read buffers. These buffers enable the VME Master to buffer two read or write transactions simultaneously.

Tsi148 provides several mechanisms to control VMEbus usage, including: time-on timer, time-off timer, and additional release mode control (see [Section 2. on page 47](#)).

1.2.4.1 Features Not Supported

The following features are not supported by the Tsi148 VME Master:

- A40 address modes
- D32 MBLT transfers

- VMEbus lock commands

1.2.5 Tsi148 as a VMEbus System Controller

The Tsi148 supports the following VMEbus system controller functions:

- VMEbus Arbiter with three modes of programmable arbitration:
 - Priority (PRI)
 - Round-Robin-Select (RRS)
 - Single Level (SGL)
- IACK Daisy-Chain Driver
- SYSRESET Driver: Provides a global system reset
- Global VMEbus Timer: Monitors the VMEbus and generates a BERR_ when there is no VMEbus activity for the programmed value
- System Clock Driver: Generates a 16 MHz system clock

1.2.5.1 Arbiter

The Tsi148 VMEbus arbiter is programmable. All three of the following arbitration modes defined by the VMEbus standard are supported:

- Priority (PRI)
- Round-Robin-Select (RRS)
- Single Level (SGL)

A 16 us arbitration timer is included in the Tsi148 to prevent a bus lock-up from occurring when no requester assumes mastership of the bus after the arbiter has issued a grant. This timer can be enabled or disabled in the VMEbus Control and Status Register (see [Section 10.4.34 on page 257](#)).

1.2.5.2 IACK Daisy-Chain Driver

An IACK Daisy-Chain driver is included in the Tsi148 as part of the system controller functionality. This feature ensures that the timing requirements for starting the IACK Daisy-Chain are satisfied.

1.2.5.3 **SYSRESET Driver**

A SYSRESET driver is included in the Tsi148 to provide a global system reset. The SRSTO signal is asserted in the following cases: the LSRSTI_ pin is asserted, the SRESET bit is asserted in the VMEbus Control Status Register, or the PURSTI_ pin is asserted. The SRSTO signal is always asserted for at least 200 ms. SRSTO is normally connected to the VMEbus SYSRESET_ signal through an inverting open collector buffer.

1.2.5.4 **Global VMEbus Timer**

The Tsi148 has a VMEbus global timer that monitors VMEbus cycles and generates a BERR signal when there is no VMEbus slave response for the programmed time period. The global timer only monitors VMEbus cycles when the system controller function is enabled. The global timer is compatible with SCT, BLT, MBLT, 2eVME, and 2eSST transfers. The global time-out period can be programmed for 8, 16, 32, 64, 128, 256, 512 μ s. This timer can be enabled or disabled in the VMEbus Control and Status Register (see [Section 10.4.34 on page 257](#)).

1.2.5.5 **System Clock Driver**

Tsi148 generates the system clock (SYSCLK) signal when it is configured as the system controller. The SYSCLK signal is in spec for the following PCI/X clock frequencies: 33.3, 66.6, 100, or 133 MHz. The SYSCLK pin is connected through an external driver to the VMEbus. SYSCLK operates at 16 MHz. The external driver is enabled through the SCON pin (see [Section 8.4.2 on page 161](#)).

1.2.5.6 **Configuration**

The system controller functions can be configured at power-up. The system controller functionality can be enabled or disabled, or the auto system controller (SCON) function can be used. The auto SCON function automatically enables the system controller functions when the board is installed in slot 1. [Table 10 on page 135](#) shows the different signal combinations that enable or disable the SCON functionality.

1.3 PCI/X Interface

The Tsi148 PCI/X Interface can operate either in PCI mode or PCI-X mode. The PCI interface is compliant with the *PCI Local Bus Specification (Revision 2.2)*, while the PCI-X interface is compliant with the *PCI-X Addendum to PCI Local Bus Specification (Revision 1.0b)*



The term *PCI/X* refers to functionality that applies to both PCI and PCI-X operating modes.

The PCI mode can operate at 33 to 66 MHz and has 32-bit/64-bit addressing and data capability. The PCI-X mode can operate at 50 to 133 MHz and has 32-bit/64-bit addressing and data capability.

For more information on the PCI/X Interface refer to [Section 3. on page 71](#).

1.3.1 PCI/X Target

The PCI and PCI-X targets are described separately in the following sections because they respond differently to read requests and use different buffering techniques for read transactions.

1.3.1.1 PCI Target

Read transactions from the PCI bus are always processed as delayed transactions. The PCI Target has a 4 Kbyte read buffer, however, in conventional PCI mode a maximum of 512 bytes are used for storing prefetched data. When processing a read request the requesting PCI bus master is issued a retry from the Tsi148 PCI Target. The read request is then forwarded to the Linkage Module and then to the Tsi148 VME Master to be serviced. One delayed read is supported by the PCI Target.

During write transactions, the PCI Target posts write data in its write buffer. The write buffer consists of a 40 entry command queue and a 4 Kbyte data queue. Tsi148 issues the initiating PCI bus master immediate acknowledgement upon the write completing. Once the posted write completes on PCI, Tsi148 obtains the VMEbus and writes the data to the VMEbus resource independent of the initiating PCI master.

For more information on buffer structure and data flow in Tsi148 refer to [Section 3. on page 71](#).

1.3.1.2 Features Not Supported

The following features are not supported by the Tsi148 PCI Target:

- No response to PCI I/O transfers
- PCI/X LOCK_ signal

- Message signalled interrupts

1.3.1.3 PCI-X Target

Read transactions from the PCI-X bus are always processed as split transactions. The PCI-X Target has a 4 Kbyte read buffer used for storing prefetched data. The requesting external PCI-X master is issued a split response from the Tsi148 PCI-X Target. The PCI-X Target supports up to six split read transactions.



Prefetching is based on the byte count received by the Tsi148 PCI-X Target.

When the read data has been retrieved from the VMEbus and sent to the PCI-X Target's read buffer, Tsi148 issues a split completion on the PCI-X bus and transfers the data from the PCI-X Target's read data buffer to the original master.

During write transactions, the PCI-X Target posts write data in its write buffer. The write buffer consists of a 40 entry command queue and a 4 Kbyte data queue. Tsi148 issues the initiating PCI bus master immediate acknowledgement upon the write completing. Once the posted write completes on PCI-X, Tsi148 obtains the VMEbus and writes the data to the VMEbus resource independent of the initiating PCI-X master.

1.3.1.4 Features Not Supported

The following features are not supported by the Tsi148 PCI-X Target:

- No response to PCI-X I/O transfers
- PCI/X LOCK_ signal
- Message signalled interrupts

1.3.2 PCI/X Master

Tsi148 requests PCI/X ownership when the PCI/X Master is internally requested by Linkage Module to service the VME Slave or the DMA controllers.

The PCI/X Master has a 4 Kbyte read buffer and 4 Kbyte write buffer.



The size of the read buffer is dependent on what PCI/X mode (PCI or PCI-X) is used in the system (see [Section 1.3.1.1 on page 39](#)).

1.3.2.1 Features Not Supported

The following features are not supported in Tsi148:

- PCI/X LOCK_ signal

— Message signalled interrupts

1.4 Linkage Module

The Tsi148 Linkage Module interconnects all the different modules that comprise Tsi148. The following modules are directly-connected to, and serviced by, the Linkage Module:

- VMEbus: Master and Slave
- PCI/X: Master and Target
- DMA Controllers
- Registers

The Linkage Module is used to arbitrate access to each interface. It controls the flow of data and data requests through the device. Every transaction processed through Tsi148 passes through the Linkage Module.

1.5 Register Overview

Tsi148's 4 Kbyte register space is called the Combined Register Group (CRG). The CRG is divided into the following groups:

- PCI Configuration Space registers (PCFS)
- Local control and status registers (LCSR)
- Global control and status registers (GCSR)
- Control and Status Registers (CSR)

For more information on Tsi148's registers, refer to [Section 10.2 on page 196](#).

Tsi148's registers can only be accessed through the Linkage Module. The interfaces that can access registers are the PCI/X Interface and the VMEbus Interface.

Figure 3: Divisions of the CRG Register Space

4 Kbyte CRG	1024 bytes	CSR
	1504 bytes	Reserved
	32 bytes	GCSR
	1280 bytes	LCSR
	256 bytes	PCFS

1.5.1 Control and Status Registers

The 512 Kbyte CR/CSR space, shown in [Figure 4](#), can be accessed from the VMEbus using the special A24 CR/CSR AM code (see [Section 2.3.1 on page 59](#)).

The Base Address is defined by either Geographical Address Implementation or Auto Slot ID. Tsi148's VME Slave can be configured at power-up to use one of the two methods (see [Section 5.4 on page 128](#)). The CR/CSR offset registers consist of an enable and a translation offset (located at offsets 0x418 – 0x420).

The address space is separated into the following areas:

- The upper 4 Kbytes defines the Tsi148 CRG
- The remaining 508 Kbytes maps to the PCI/X bus.
 - When an access is initiated on the VMEbus using A24 CR/CSR AM code, Tsi148 initiates an access on the PCI/X bus when the CR/CSR offset register is enabled.

Figure 4: CR/CSR Register Space

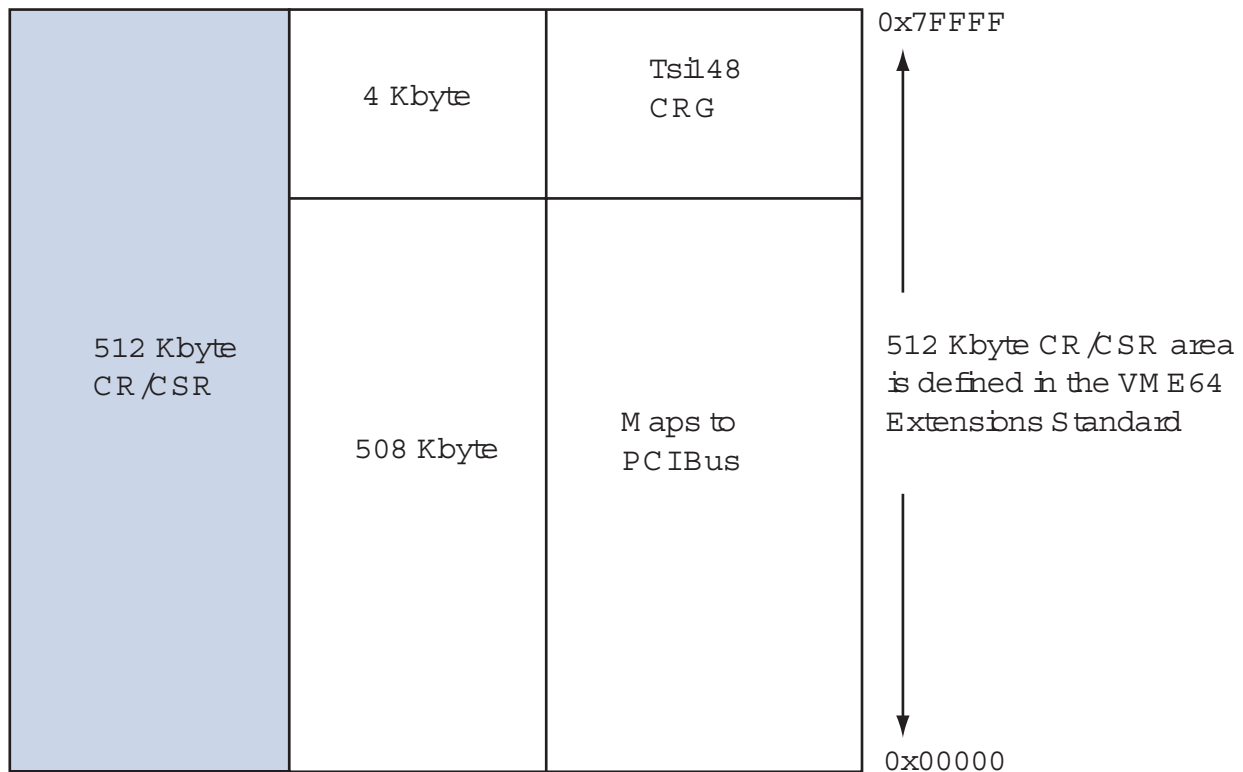

1.6 DMA Controllers

Tsi148 has two internal, independent, single channel DMA controllers for high performance data transfers. DMA operations between the source and destination bus are managed as separate transactions through the Linkage Module. Transactions are buffered in each DMA controller's 64-bit by 1024 (8 Kbyte) entry buffer. The Tsi148 DMA Controllers support both Direct mode and Linked-list mode operation.

There are no restrictions on addressing alignment or transfer sizes (transfer sizes can range anywhere from 1 byte to 4 Gbytes). There is support for transfer throttling through programmable transaction block sizes. There is also a back-off timer, which enables DMA transfers to occur in certain (programmable) periods of time. Parameters for DMA transfers are configured by software, or linked-list, activity.

The principal mechanism for DMA transfers is the same for operations in either direction (PCI-to-VMEbus, or VMEbus-to-PCI), only the identity of the source and destination bus changes. In a DMA transfer, the Tsi148 gains control of the source bus and reads data into the read buffer of the source master, then passes the data through the Linkage Module and into the DMA data buffer. The DMA controller then requests a transaction through the linkage and passes the data through the linkage and into the destination write buffer. The destination master then acquires the destination bus and empties its write buffer.

The DMA controller can be programmed to perform multiple blocks of transfers using Linked-list mode. The DMA works through the transfers in the linked-list following pointers at the end of each linked-list entry. Linked-list operation is initiated through a pointer in an internal Tsi148 register, but the linked-list itself resides in PCI/X memory.

For more information on Tsi148's DMA Controller refer to [Section 4. on page 99](#).

1.6.1 Data Movement

The DMA controllers support the following data movement scenarios:

- PCI/X-to-VME: Data is read from PCI/X and written to VME. The DMA buffer is emptied while being filled.
- VME-to-PCI/X: Data is read from VME and written to PCI/X. The DMA buffer is emptied while being filled.
- PCI/X-to-PCI/X: Data is read from PCI and written back later.
- VME-to-VME: Data is read from VME and written back later
- Data Pattern-to-VME: Data pattern written into DMA buffer, then written to VMEbus. The DMA buffer is emptied while being filled.



Data patterns can be used for system debugging or clearing registers.

- Data Pattern-to-PCI/X: Data pattern written into DMA buffer, then written to PCI/X bus. The DMA buffer is emptied while being filled.

1.7 Interrupter and Interrupt Handler

Tsi148 can be programmed to act as interrupter and an interrupt handler in a VME system. As an interrupter, Tsi148 is capable of asserting interrupts on IRQ[7:1]O.

As an interrupt handler, Tsi148 has several VMEbus Interrupt Acknowledge registers which, when read, generate an IACK cycle on the VMEbus (see [Section 10.4.70 on page 313](#)).

1.8 JTAG

Tsi148 has a dedicated user-accessible test logic that is fully compatible with the *IEEE 1149.1 Standard Test Access Port and Boundary-Scan Architecture*; also referred to as JTAG (Joint Test Action Group).

For more information on Tsi148's JTAG capability refer to [Section 7. on page 141.](#)

2. VME Interface

This chapter describes the main features and functions of the Tsi148 VME Interface. The following topics are discussed:

- “Overview of the VME Interface” on page 48
 - “VME Slave” on page 48
 - “VME Master” on page 59
-

2.1 Overview of the VME Interface

The Tsi148 VME Interface is compliant with the following standards:

- *American National Standard for VME64*
- *American National Standard for VME64 Extensions*
- *Source Synchronous Transfer (2eSST) Standard*

The interface is separated into VME Slave and VME Master modules. The Tsi148 has been designed so that it can accept its own transaction on the VMEbus. If the Tsi148 VME Master initiates a transaction on the VMEbus, and the address falls within the inbound address window for the Tsi148 VME Slave, then the VME Slave accepts the cycle. For more information on VME master and slave transactions, refer to [Section 2.2.1.2 on page 52](#) and [Section 2.3 on page 59](#).

2.2 VME Slave

The VME Slave is responsible for tracking and maintaining coherency to the VMEbus protocols. The VME Slave supports A16, A24, A32, and A64 address spaces and D8, D16, D32, and D64 data transfer sizes. The VME Slave supports SCT, BLT, MBLT, 2eVME, and 2eSST protocols.

During a read transaction, the VME Slave does not assert the DTACK* signal to acknowledge the data until after the data has been received from the PCI/X bus. During write transactions, the VME Slave posts the data into the write buffer. The VMEbus considers the write complete, and Tsi148 manages the completion of the write posted transaction on the PCI/X bus.

All transactions are completed on the PCI/X bus in the same order that they are completed on the VMEbus. A read transaction forces all previously issued posted write transactions to be flushed from the write buffers. All posted write transfers are completed before a read is begun to make sure that all transfers are completed in the order issued.

2.2.1 VME Slave Buffers

The VME Slave has a single read buffer that stores command information when servicing a transaction from the VMEbus, and receives the read data from the Linkage Module after the PCI/X Master has retrieved the data from the PCI/X bus. The read buffer is segmented into two parts: a data queue and a command queue. The command queue stores address and command information for a single VMEbus transaction. The amount of data in read buffer depends on the type of transaction requested. The data queue can store up to 2 Kbyte of data.

The single write buffer receives data and commands from the VMEbus. The write buffer is segmented into two parts: data queue and command queue. The data queue is designed for large burst transfers and supports up to 4 Kbyte of data. The command queue stores address and command information and can accept six entries. The write buffer is considered full when either the command or data queue is full.

2.2.1.1 Transaction Mapping

The VMEbus is capable of many different transaction types, including one to four byte single beat transactions and burst transactions. These transactions must be mapped to corresponding transactions on the PCI/X bus. The Tsi148 supports all the different modes and protocols supported by the PCI/X bus and has numerous programmable options. Because of this flexibility there are many possible types of transactions between VME and PCI/X. The following rules can be applied to transactions:

1. A one, two, three, or four byte read or write on the VMEbus always maps to a corresponding read or write on the destination bus. VMEbus block reads can cause data to be prefetched from the PCI/X bus. Any locations with read sensitive bits should be accessed using a Single cycle Transaction (SCT) read that matches the width of the location. There is a one-to-one correspondence between the bytes written on the VMEbus and bytes written on the PCI/X bus.
2. The VME Slave does not merge, combine, or gather transactions. A transaction that completes in a single bus tenure on the VMEbus may not complete in a single bus tenure on the destination bus.
3. The VME Master does not generate the two and three byte unaligned transactions defined in the *American National Standard for VME64*.

VMEbus-to-PCI Address Mapping

The VME Slave interface maps a VMEbus address to the PCI/X bus address space using eight programmable slave images (see [Section 10.4.46 on page 281](#)). These slave images provide windows into the PCI/X bus from the VMEbus. The VMEbus address is compared with the address range of each slave image, and if the address falls within the specified range, an offset is added to the incoming address to form the PCI/X bus address.

The incoming address is within the slave images window if the incoming address is greater than or equal to the starting address and less than or equal to the ending address.



All programmable slave images should decode unique address ranges. However, if the slave images overlap, slave image zero has the highest priority and slave image seven has the lowest priority.

The address space of the current VME transaction determines how address comparisons are performed. The following list gives example programming and comparisons for the address mapping:

- If the VMEbus address is 64-bits, then bits 31 to 0 of the starting address in the Inbound Translation Starting Address Upper (ITSAU_x) register (see [Section 10.4.46 on page 281](#)) and bits 31 to 16 of the starting address in the Inbound Translation Starting Address Lower (ITSAL_x) register (see [Section 10.4.51 on page 286](#)) and bits 31 to 0 of the ending address in the Inbound Translation Ending Address Upper (ITEAU_x) register (see [Section 10.4.48 on page 283](#)) and bits 31 to 16 of the ending address in the Translation Ending Address Lower (ITEAL_x) register (see [Section 10.4.49 on page 284](#)), are compared against VMEbus address bits 63 to 16.
- If the VMEbus address is 32-bits, then bits 31 to 16 of the starting address in the ITSAL_x register and bits 31 to 16 of the ending address in the ITEAL_x register are compared against VMEbus address bits 31 to 16. The granularity is 64 Kbytes.
- If the VMEbus address is 24-bits, then bits 23 to 12 of the starting address in the ITSAL_x register and bits 23 to 12 of the ending address in the ITEAL_x register are compared against VMEbus address bits 23 to 12. The granularity is 4 Kbytes.
- If the VMEbus address is 16-bits, then bits 15 to 4 of the starting address in the ITSAL_x register and the bits 15 to 4 of the ending address in the ITEAL_x register are compared against VMEbus address bits 15 to 4. The granularity is 16 bytes.



There are no limits imposed on how large an address space a slave image can represent.

Each slave image has a set of attributes that are used to enable the image and define the VMEbus transfer characteristics. Each image is has an attribute register (see [Section 10.4.52 on page 287](#)) with the following fields:

- Image enable
- Programmable threshold for read-ahead prefetching
- Programmable virtual FIFO size for inbound prefetch reads
- 2eSST slave response rate control: 160, 267, or 320 MB/s
- Slave response control: SCT, BLT, MBLT, 2eVME, 2eSST, 2eSST broadcast
- Slave address space response control: A16, A24, A32, or A64
- Slave response control: VMEbus non-privileged, supervisory, program and data access cycles

Each slave image also includes a programmable address offset. The offset is added to the VMEbus address, and the result is used as the PCI/X bus address. **Figure 5** shows the programmable starting address, ending address, and translation offset.

Figure 5: Slave Image Programmable Address Offset

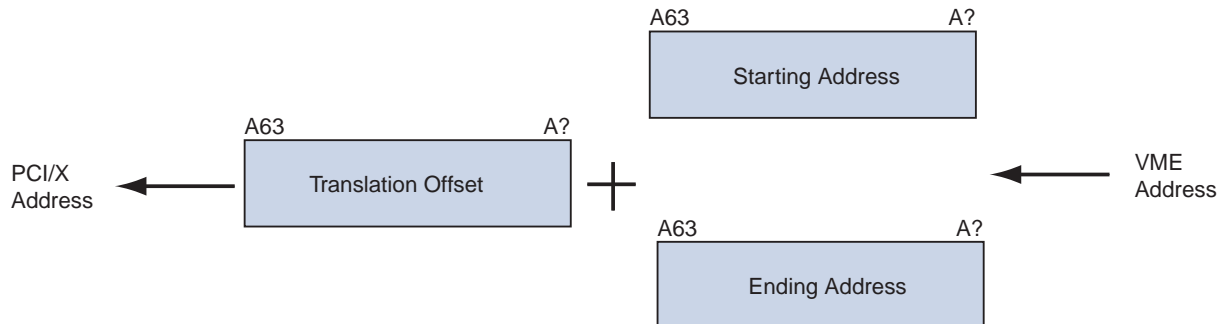

In **Figure 5** the width of the starting address, the ending address, and the translation offset depends on the VME address bus size. In **Figure 5** this dependency is represented by A?.

The following lists illustrates the address translation process for various VMEbus address spaces:

- If the VMEbus address is 64-bits, then bits 31 to 0 of the offset in the Inbound Translation Offset Upper (ITOFU_x) register (see [Section 10.4.50 on page 285](#)) and bits 31 to 16 of the offset in the Inbound Translation Offset Lower (ITOFL_x) register (see [Section 10.4.51 on page 286](#)) are added to VMEbus address bits 63 to 16.
- If the VMEbus address is 32-bits, then the incoming VMEbus address bits 63 to 32 are forced to zero and then bits 31 to 0 of the offset in the ITOFU_x register and bits 31 to 16 of the offset in the ITOFL_x register are added to VMEbus address bits 31 to 16.
- If the VMEbus address is 24-bits, then the incoming VMEbus address bits 63 to 24 are forced to zero and then bits 31 to 0 of the offset in the ITOFU_x register and bits 31 to 12 of the offset in the ITOFL_x register are added to VMEbus address bits 23 to 12.
- If the VMEbus address is 16-bits, then the incoming VMEbus address bits 63 to 16 are forced to zero and then bits 31 to 0 of the offset in the ITOFU_x register and bits 31 to 4 of the offset in the ITOFL_x register are added to VMEbus address bits 15 to 4.

2.2.1.2 VME Slave Transactions

The Tsi148 VMEbus Interface supports different transaction types, including one to four byte single beat transactions, and burst transactions. These transactions must be mapped to corresponding transactions on the destination bus. For more information on transaction mapping, refer to [Section 2.2.1.1 on page 49](#).

VME Slave Read Transaction

VME Slave read operation depends on whether the transfer is a block or single cycle. If the transfer is a SCT, the VME Slave requests a single beat transfer from the Linkage Module. The VMEbus acknowledgement is held until the data is received from PCI/X.

If the read operation is a block transfer, the VME Slave requests a block of data from the Linkage Module. The VME Slave read buffer is used to store the data received from the Linkage Module. The data is stored in the buffer until it is needed to complete a VMEbus transaction.

The VME Slave read buffer has a programmable virtual buffer size and refill threshold. This flexibility enables the buffer to be optimized for various block sizes. The virtual buffer size can be set to 64, 128, 256 or 512 bytes. The virtual buffer size and refill threshold are programmable in the Slave Image registers (see [Section 10.4.46 on page 281](#)).

When the VME Slave receives a BLT or MBLT read command, the VME Slave prefetches data (through the Linkage Module to get the data) based on the virtual buffer size.



Prefetching is not used during Single Cycle Transfers.

As data is removed from the VME Slave read buffer, it is refilled based on the refill threshold. The refill threshold can be set to half-full or empty. When the refill threshold is set to half-full, the VME Slave read buffer is refilled when it is less than half-full. This functionality enables the VMEbus master to read data from PCI/X without interruption. In applications where the packet size is small, the data from the initial read can be all that is required and reading additional data would waste PCI/X bus bandwidth. In this case, the refill threshold can be set to empty to conserve bandwidth on the PCI/X bus. If the buffer is drained and additional data is required by the VME Master, the buffer is refilled based on the buffer size and address.

When the VME Slave receives a 2eVME or 2eSST read command, the prefetch size is determined by the byte count received from the VMEbus master. The entire byte count is read on the PCI/X bus. Tsi148 supports the maximum 2eVME/2eSST byte-count of 2 Kbytes.

Example VME Slave Read Transaction

In this example VME-to-PCI-X read, the transaction is separated into Request and Completion phases. The following list, and **Figure 6**, show the steps taken in the first part of the transaction (Request) and in the second part of the list, and **Figure 7**, shows the next part of the transaction (Completion).

1. A VMEbus master initiates a SCT, BLT, MBLT, 2eVME, or 2eSST read request to a PCI/X peripheral.

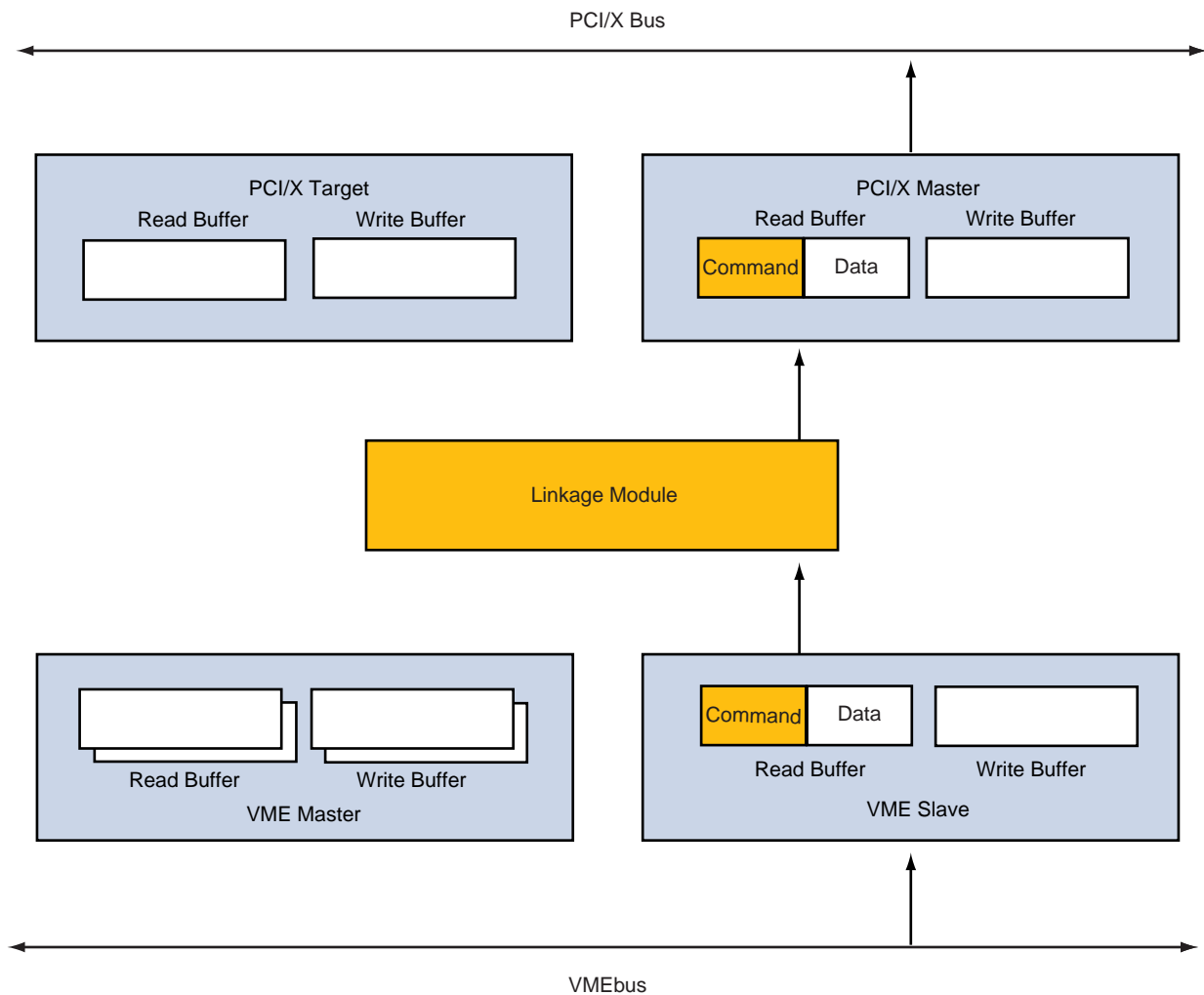
Figure 6: VMEbus to PCI/X Read Request

2. Tsi148 stores the command and address information, as well as byte count information (if it is a 2eVME or 2eSST request) in the VME Slave's read buffer command queue
 - Tsi148 supports one read request at a time

3. The VME Slave makes a read request to the Linkage Module. The initial amount of data requested is determined by the block transfer type.
 - If the transaction is a SCT, the VME Slave requests a single beat transfer from the Linkage Module.
 - If the transaction is a block transfer the VME Slave uses the virtual size buffer to determine how many bytes to request from the Linkage Module.
 - Since 2eVME and 2eSST transfers include a byte count, the VME Slave requests the entire byte counts.
4. After arbitration, the Linkage Module command and address information is passed to the PCI/X Master's read buffer command queue. The PCI/X Master's command queue is six entries deep.
5. The PCI/X Master issues the read request to the PCI/X target.

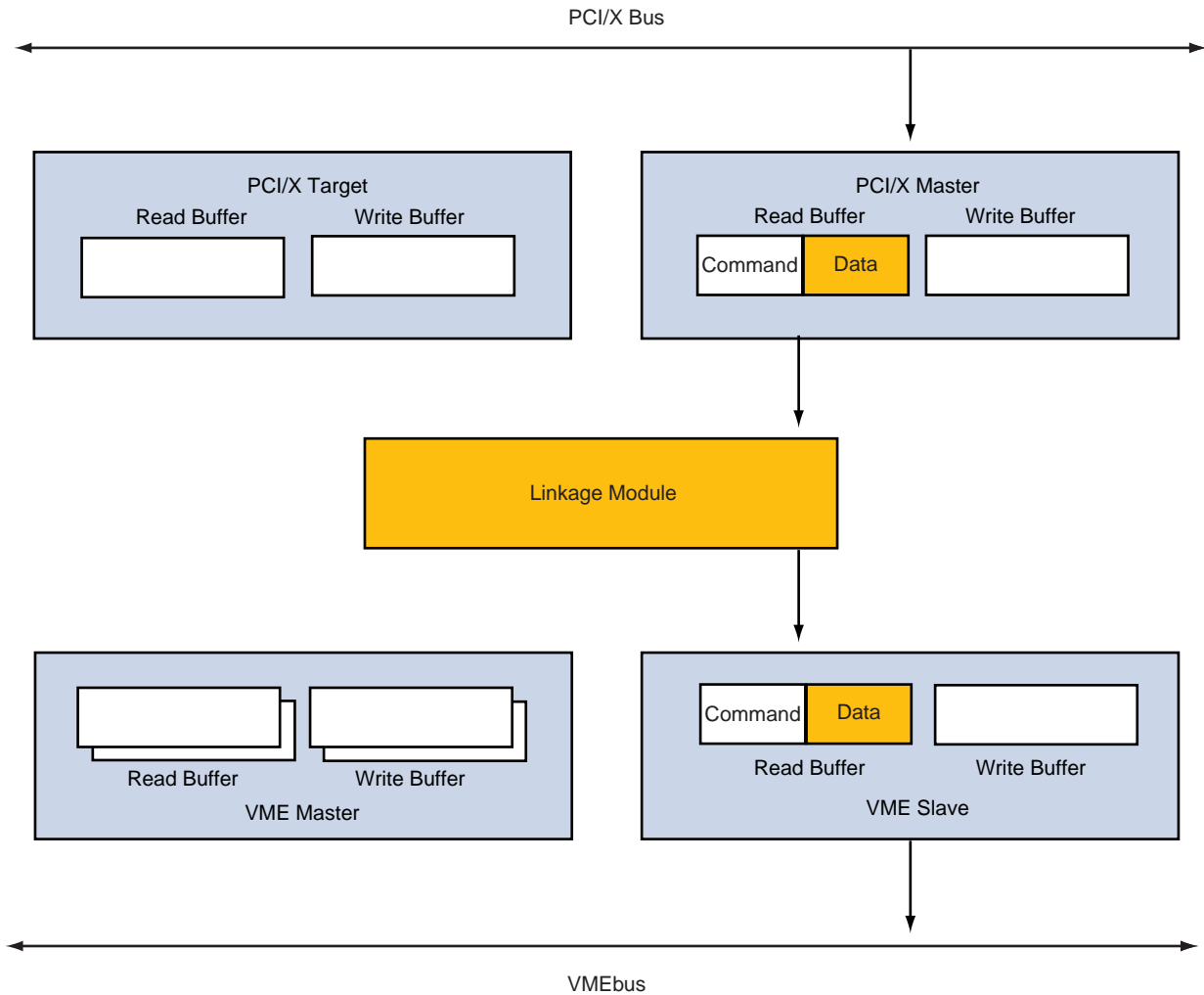
Figure 7: VMEbus to PCI/X Read Completion

6. The PCI/X target satisfies the read request and the data is stored in the PCI/X Master's read buffer data queue.
7. The PCI/X Master makes a request to the Linkage Module.
8. After arbitration, the read data is passed through the Linkage Module to the VME Slave's read buffer data queue. The 2 Kbyte VME Slave's read buffer data queue is used to store data received from the Linkage Module.
9. Once the VME Slave's read buffer data queue is full (based on the virtual size programmed or byte count received), the read data is passed to the initiating VMEbus master.

- If the AS signal is asserted and the refill threshold has been reached in the VME Slave's read buffer data queue, the VME Slave requests the Linkage Module to return to the PCI/X bus for more data.

VME Slave Write Transaction

During write transactions, the external master posts write data into the write buffer. All writes are posted and the write buffer stores the data necessary to complete the transfer and immediately acknowledges the transaction on the VMEbus. Tsi148 manages the completion of the posted write transaction.

Example VME Slave Write Transaction

In this example VME-to-PCI/X write transaction, the data passes through Tsi148 through the VME Slave, to the Linkage Module, and ends at the PCI/X Master. The following list, and [Figure 8](#), show the steps taken in the write transaction.

1. A VMEbus master initiates a write to a PCI/X target.

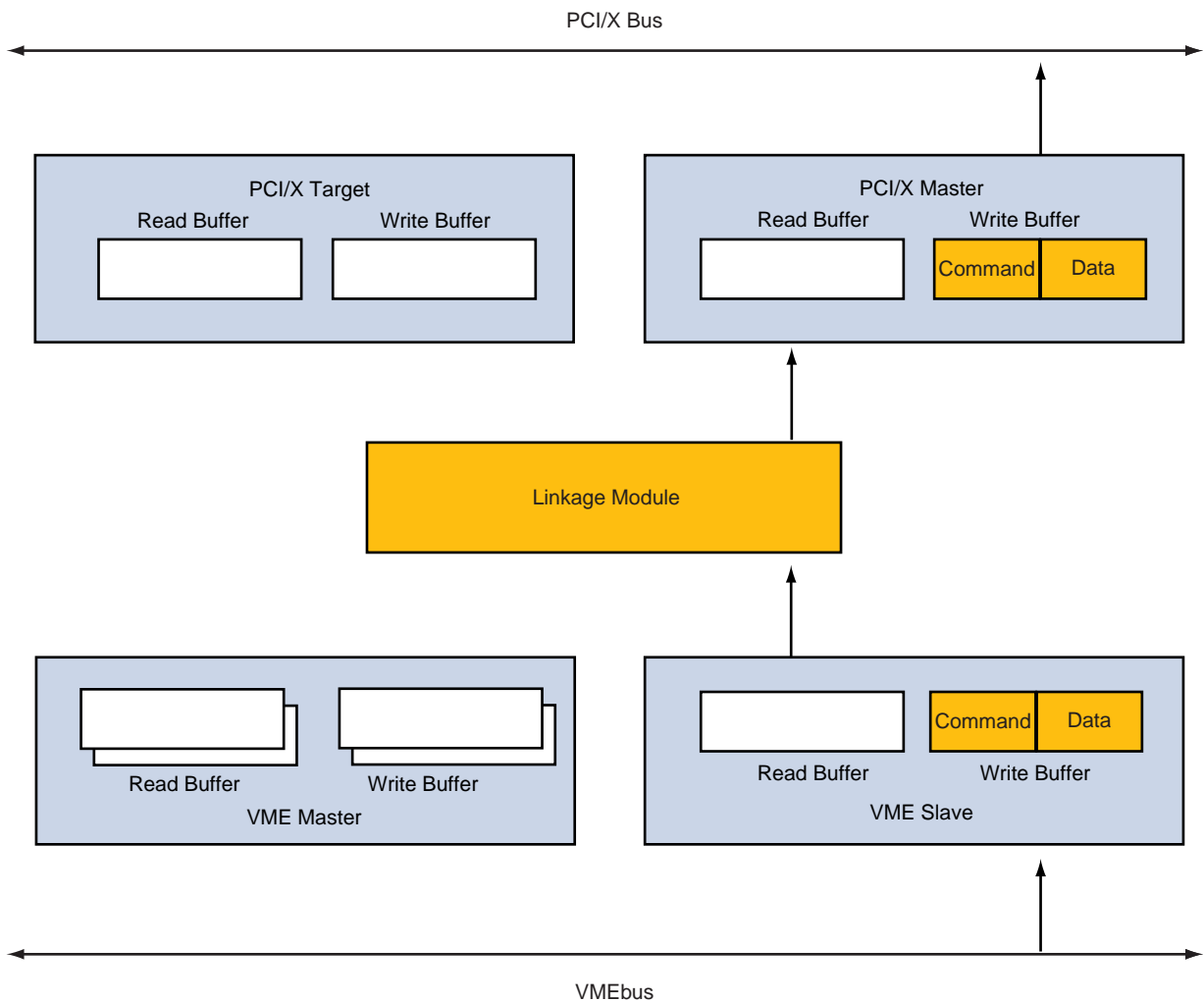
Figure 8: VMEbus to PCI/X Write

2. The VME Slave queues the address and command information within its write buffer command queue. The command queue is six entries deep.
 - All write transactions are posted within the VME Slave's write buffer data queue.
 - The VME Slave's write buffer data queue is 4 Kbytes.

3. Once the transaction completes on the VME bus (that is, all the data is placed within the VME Slave's write buffer data queue) the VME Slave sends a request to the Linkage Module.
4. After arbitration by the Linkage Module, the command and address information, as well as the write data, is passed to the PCI/X Master's write command and data queue.
 - The PCI/X Master's write buffer data queue is 4 Kbytes and the command queue (which is used to store commands from Linkage Module) is six entries deep.
5. The PCI/X Master completes the write transaction to the PCI/X target.

2.2.1.3 VME Slave Read-Modify Write (RMW) Cycles

The Tsi148 VME Slave responds to RMW cycles. The VME Slave does not complete VMEbus RMW cycles as indivisible cycles on the PCI/X bus. The PCI/X bus LOCK_ signal is not supported by the Tsi148 PCI/X Master and therefore the read and write cycles are divisible on the PCI/X bus.

For information on how Tsi148 generates RMW cycles as a VME Master, refer to [Section 2.3.3 on page 60](#).

2.2.1.4 Terminations

The VME Slave can terminate a SCT, BLT, or MBLT cycle with a DTACK_ signal or a RETRY_ signal. The VME Slave never terminates a SCT, BLT, or MBLT cycle with a BERR_ signal.

All 2eVME and 2eSST cycles are terminated with a normal termination or retry signal. The VME Slave never terminates a 2eVME or 2eSST cycle with a slave termination or error termination.

2.3 VME Master

The VME Master provides the interface from Linkage Module to the VMEbus. The VME Master can generate A16, A24, A32, and A64 VMEbus address cycles and D8 even, D8 odd, D16, D32, and D64 data transfers. The VME Master generates transfers using the SCT, BLT, MBLT, 2eVME, and 2eSST protocols. The VME Master supports the VMEbus RETRY_ signal.

2.3.1 Addressing Capabilities

The Tsi148's VMEbus addressing mode is controlled by programming the Outbound Translation Attribute registers (see [Section 10.4.26 on page 243](#)). The Tsi148 is capable of generating A16, A24, A32, A64, and CR/CSR address phases. The address mode and type (supervisor and program) are also programmed through the Outbound Translation Attribute registers.

The address and Address Modifier (AM) codes that are generated by the Tsi148 are functions of the mapping of the PCI/X memory space as defined above or through DMA programming (see [Section 10.4.88 on page 349](#) and [Section 10.4.89 on page 353](#)). [Table 1](#) shows the AM codes used for the VMEbus.

Table 1: VMEbus Address Mode Codes

AMODE	Address Mode
0x0000	A16
0x0001	A24
0x0010	A32
0x0011	Reserved
0x0100	A64
0x0101	CR/CSR
0x0110	Reserved
0x0111	Reserved
0x1000	User1 (AM 0x0100xx)
0x1001	User2 (AM 0x0101xx)
0x1010	User3 (AM 0x0110xx)
0x1011	User4 (AM 0x0111xx)
0x1100	Reserved

Table 1: VMEbus Address Mode Codes

AMODE	Address Mode
0x1101	Reserved
0x1110	Reserved
0x1111	Reserved

There are four user defined AM codes. When the user defined AM codes are used, the AM[1] bit is defined by the VMEbus Supervisory Mode (SUP) bit and the AM[0] bit is defined by the VMEbus Program Mode (PGM) bit in the Outbound Translation Attribute register (see [Section 10.4.26 on page 243](#)).

2.3.2 VME Master Buffers

The VME Master interfaces to the Linkage Module through separate read and write buffers. The VME Master has two write buffers and two read buffers.

The read buffers are each segmented into two parts: the data queue and the command queue. The read buffers are used to store data received from the VMEbus. The data queue can accept up to 4 Kbytes of data. The command queue stores a single entry. The two read buffers allows the Tsi148 to perform back-to-back reads from the VMEbus.

The write buffers are each segmented into two parts: the data queue and the command queue. The data queue can have up to 4 Kbytes of data. The command queue can accept one entry. The write buffers are used to receive writes from the Linkage Module. The two write buffers allow the VME Master to accept two Linkage Module commands. The two write buffers allows the Tsi148 to perform back-to-back writes from the VMEbus.

2.3.3 VME Master Read-Modify Write (RMW) Cycles

A RMW cycle allows the VME Master to read from a VMEbus slave and then write to the same resource without relinquishing bus tenure between the two operations. RMW cycles can be generated by the Tsi148 VME Master. The VME Master generates RMW cycles on 8, 16, and 32-bit aligned transfers. For more information on the VME RMW registers, refer to [Section 10.4.29 on page 249](#).

The following registers are used when the RMW functionality is enabled

- The VMEbus RMW Address Upper (RMWAU) and VMEbus RMW Address Lower (RMWAL) registers: These registers specify the PCI/X address, both the upper bits (63:32) and lower bits (31:2), for the RMW cycle.

- VMEbus RMW Enable (RMWEN): This register defines the bits that are involved in the compare and swap operations of the RMW cycle.
- VMEbus RMW Compare (RMWC): This register defines the bits which are compared with the data read from the VMEbus.
- VMEbus RMW Swap (RMWS): This register defines the bits written to the VMEbus when the compare is successful.

The following steps are used to perform RMW cycles on the VMEbus (see [Figure 9](#)).

1. A PCI/X bus read access address matches the Target Address
 - The Target Address must be mapped to the VMEbus by one of the PCI/X bus-to-VME Slave images.
2. The VME Master reads the data at the Target Address.
3. The VME Master completes the read on the VMEbus.
4. The data read from the Target Address is compared with the data in the Compare register.
 - The bits in the RMW Enable register determine which bits are compared.
5. When the enable register is set and the compare is true, the enabled bits which compare are replaced with the data in the swap register and are written to the VMEbus. The bits which do not compare are written to the VMEbus without modification.
6. The data read from the VMEbus is returned to the PCI/X Master.

Figure 9: Steps Used to Perform RMW Cycles on the VMEbus

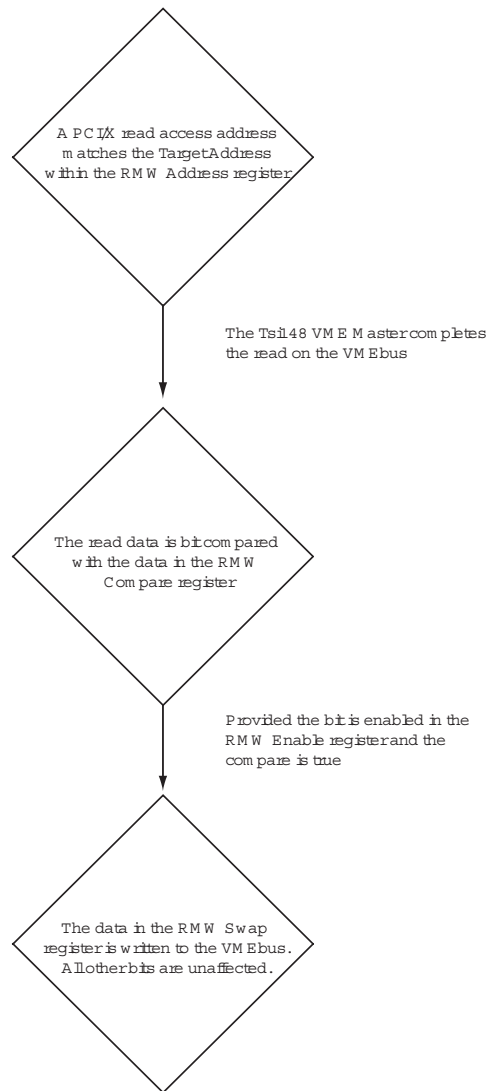

For information on how Tsi148 responds to RMW cycles as a VME Slave, refer to [Section 2.2.1.3 on page 58](#).

2.3.4 VME Master Bandwidth Control

The VME Master has features to control VMEbus usage which can all be programmed in the VME Master Control register (see [Section 10.4.33 on page 253](#)). The features include the following:

- Time-on timer
 - The time-on timer specifies the length of time the VME Master can use the VMEbus.

- Time-off timer
 - The time-off timer specifies the length of time the VME Master must wait before re-requesting the VMEbus.
- Release mode control
 - The release mode control bits define when the VME Master releases the VMEbus.

The VME Master requests the VMEbus when it receives a command from the Linkage Module or if a previously received command is not completed and the time-off timer has expired. Once the VME Master has acquired the VMEbus, it maintains bus ownership until one of the release conditions is met (see [Section 2.3.4.1 on page 63](#)).

2.3.4.1 VME Master Release Conditions

Tsi148 releases control of the VMEbus after it has been granted control as the VME Master when one of the following VMEbus release conditions are met:

- The VMEbus is released when the time-on timer has reached its terminal count or the master is *done*



The term *done* means the VME Master has completed the transfer and has no other requests in the queue.

- The VMEbus is released when the time-on-timer has reached its terminal count and there is a VMEbus request or the VME Master is *done*. This mode enables the master to continue using the VMEbus, if no other master is requesting the bus, even though the time has expired.
- The VMEbus is released when the time-on timer has reached its terminal count and the VMEbus BCLR_ signal is asserted or the VME Master is *done*. This mode enables the master to continue using the VMEbus, if no other master is requesting the bus at a higher priority, even though the time has expired. The BCLR_ signal is asserted by the arbiter when a higher priority request is received (see [Section 8.4.2 on page 161](#)).
- The VMEbus is released when the time-on timer has reached its terminal count or the VME Master is *done* and there is a VMEbus request. This enables the VME Master to maintain VMEbus ownership even when there is no transfer in progress. Bus mastery is maintained until another master requests the bus.

2.3.5 VMEbus Exception Handling

When a VMEbus transfer initiated by the VME Master does not complete successfully, the status is saved in the VMEbus exception registers. The exception registers are updated when a transaction is terminated with a bus error, or a 2eVME or 2eSST transfer is terminated with a slave termination.

The VMEbus exception registers include:

- VMEbus Exception Address Upper (VEAU)
- VMEbus Exception Address Lower (VEAL)
- VMEbus Exception Attributes (VEAT)

For more information on the VMEbus exception registers, refer to [Section 10.4.38 on page 269](#)).

When the VME Master encounters one of these conditions, any write data in the buffers is removed (flushed). If the transaction was a VMEbus read, the VME Master completes the Linkage Module command by filling the buffer with a data pattern of all ones.

If a second exception occurs before the software has acknowledged the first exception, the status registers are not updated, however, the overflow bit is set to indicate that more than one exception occurred.



The interrupt controller can be programmed to generate an interrupt when the exception registers are updated.

2.3.6 Utility Functions

Tsi148 provides the following VMEbus utility functions:

- VMEbus Location Monitor which allows one VMEbus board to broadcast an interrupt to multiple boards. The processor sends an interrupt by reading, or writing to, one of the VMEbus monitored addresses. Other boards in the system monitor this address and interrupt their processors when an access is detected. The monitored VMEbus addresses are programmable and works in A16, A24, A32, and A64 VMEbus address space (see [Section 2.3.6.1 on page 65](#)).

Three registers are provided for this function: Location Monitor Base Address Upper register (LMBAU), Location Monitor Base Address Lower register (LMBAL), and Location Monitor Attribute register (LMAT) (see [Section 10.4.62 on page 302](#)).

- Eight Semaphore registers for resource sharing (see [Section 2.3.6.2 on page 66](#)).
- Four Mailbox registers used to provide a communication path between the VMEbus and PCI/X Logic (see [Section 2.3.6.3 on page 67](#)).

- Logic is provided to generate VMEbus system fail and board fail signals (see [Section 5.4.2.4 on page 134](#))
- Power-up options are provided for CR/CSR Base Address Configuration. Tsi148's VME Slave can be configured at power-up to use 1 of 2 methods: Geographical Address Implementation or Auto Slot ID (see [Section 5.4.2 on page 130](#)).
- Supports the following two non-standard VMEbus features: Broadcast Interrupt, Clock and 64-bit Counter (see [Section 2.3.6.4 on page 67](#)).

2.3.6.1 VMEbus Location Monitor

Location monitor functionality allows one VMEbus board to broadcast an interrupt to multiple boards. All boards which are participating in the broadcast are programmed to monitor a set of VMEbus addresses.

The Tsi148 location monitor is enabled in the Location Monitor (LMAT) Register by setting the Enable (EN) bit (see [Section 10.4.64 on page 304](#)). The monitored VMEbus addresses are programmable in the Location Monitor Base Address Upper (LMBAU) register (see [Section 10.4.62 on page 302](#)) and Location Monitor Base Address Lower (LMBAL) register (see [Section 10.4.63 on page 303](#)).

The location monitor can monitor addresses in VMEbus A16, A24, A32 or A64 space. If the VMEbus address is 64-bits, then bits 31 to 0 of the base address in the LMBAU register and bits 31 to 5 of the base address in the LMBAL register are compared against VMEbus address bits 63 to 5. If the VMEbus address is 32-bit, then bits 31 to 5 of the base address in the LMBAL register are compared against VMEbus address bits 31 to 5. If the VMEbus address is 24-bits, then bits 23 to 5 of the base address in the LMBAL register are compared against VMEbus address bits 23 to 5. If the VMEbus address is 16-bits, then bits 15 to 5 of the base address in the LMBAL register are compared against VMEbus address bits 15 to 5.

The processor sends an interrupt by reading or writing one to the VMEbus monitored address. The other boards in the system monitor this address and interrupt their processors when an access is detected. There are four locations which are monitored and each location is eight bytes. VMEbus address bits 3 and 4 are used to define the specific location. [Table 2](#) shows the relationship between the VMEbus address and the location monitor interrupt.

Table 2: Location Monitor Interrupt Addresses

VMEbus Address	Location Monitor Interrupt
LMBA + (0-7)	LM0
LMBA + (8-F)	LM1
LMBA + (10-17)	LM2
LMBA + (18-1F)	LM3

When the location monitor detects an access to one of the locations being monitored, an interrupt is sent to the interrupter. If the interrupt is enabled, then the selected INTx signal is asserted. The status of the interrupt is available in the Global Control and Status (GCSR) registers (see [Section 10.2.4 on page 197](#)) and Local Control and Status (LCSR) registers (see [Section 10.2.3 on page 197](#)).

No data is transferred during a Location Monitor access. The slave boards monitoring the location do not respond. The board generating the location monitor cycle is responsible for terminating the VMEbus cycle with a DTACK* signal. The board generating a location monitor cycle must have its location monitor enabled and programmed to monitor the location monitor address.

2.3.6.2 Semaphore Registers

The GCSR registers include eight semaphore registers. These semaphore registers can be used to allow processes running on the local processor and processes running on processors on other VMEbus boards to share resources. Each semaphore register is 8-bits and there are four semaphore registers in a 32-bit register. The most significant bit (bit 7) is the semaphore bit and the remaining seven bits (bits 6 to 0) are the tag field.

To gain ownership of the semaphore, a process writes to the semaphore with bit 7 set and a unique code in the tag field. The process has gained ownership if a subsequent read returns the unique code. The process releases the semaphore by setting the semaphore register to 0.

A semaphore register is only updated when bit 7 in the register is zero and a one is written to bit 7 of the register, or when a zero is written to bit 7.

2.3.6.3 Mailbox Registers

The GCSR includes four mailbox registers which can be used to provide a communication path between the VMEbus and the PCI/X bus. These registers support read and write access from the PCI/X bus and the VMEbus. When the least significant byte of a mailbox register is written, an interrupt is sent to the interrupter. If the interrupt is enabled, an INTx signal is generated.



RMW access to a mailbox register from the VMEbus is not guaranteed to be indivisible. The semaphore registers should be used to control access if the RMW feature is required.

2.3.6.4 Broadcast Interrupt and 64-bit Counter

There are two Tsi148 VMEbus features which use the IRQ[1]_ or IRQ[2]_ signal lines in a device specific way: the Broadcast Interrupt and 64-bit Counter.



When the IRQ[1]_ or IRQ[2]_ signal lines are used for the Broadcast Interrupt or 64-bit Counter features, they must not be used for VMEbus interrupt signals by any other boards. These features are not defined in the VMEbus standards. The features can be programmed in the VMEbus Interrupt Control registers (see [Section 10.4.70 on page 313](#)).

The IRQ[1]_ and IRQ[2]_ signal lines received from the VMEbus can be routed to several internal modules. They are always sent to the local bus interrupter as standard interrupts. They may be sent to the local bus interrupter as an edge sensitive interrupt or they can be sent to a 64-bit counter.

The following functions can be assigned to the IRQ[1] or IRQ[2] signal lines:

- VMEbus Interrupter: The VMEbus interrupter allows VMEbus interrupts to be generated as defined in the VMEbus standard. For more information see [“Interrupt Controller” on page 137](#).
- Programmable Pulse Generator: This generator allows a pulse on the VMEbus IRQ[1]O or IRQ[2]O signal line to be generated. The width of the pulse generated is programmable from 120 ns to 1.97 ms in approximately 30ns increments.
- Programmable Clock Generator: Enables a free running clock to be generated on IRQ[1] or IRQ[2]. The period of the clock generator is programmable from 2.04us to 17.11sec in approximately 1.02us increments. This provides frequencies from 0.49MHz to 0.06Hz.
- Fixed 0.98MHz clock: Generated on IRQ[1] or IRQ[2] signal line.

Broadcast Interrupt

Although the Tsi148 IRQ[1] and IRQ[2] signals can be used as VMEbus interrupts (as defined by the *American National Standard for VME64 Extensions*), the Tsi148 can also use one of the IRQ[1] or IRQ[2] signals as a broadcast interrupt. The broadcast interrupt allows a board to send an interrupt to multiple boards. Since all the boards receive the interrupt at the same time, the interrupt can be used as a synchronizing event.

In this mode, the transmitting board transmits a pulse on the IRQ[1] or IRQ[2] signal line. The receiving boards are programmed to treat the IRQ[1]_ or IRQ[2]_ signal as an edge sensitive interrupt. There is no VMEbus interrupt acknowledge cycle for a broadcast interrupt. The interrupt is treated as a local interrupt on the receiving boards.



The transmitting board can also be a receiving board.

An interrupt can be broadcast in multiple ways. Either the pulse generator can be programmed to generate a single broadcast interrupt or the programmable clock generator can be used to generate periodic broadcast interrupts. When the pulse generator is enabled and the BIP bit is set in the VMEbus Interrupt Control register (see [Section 10.4.69 on page 310](#)), a single interrupt is broadcast.

The Broadcast Pulse Generator Timer register (see [Section 10.4.67 on page 308](#)) is used to program the pulse width. A new pulse should not be generated when the BIPs bit is set in the VMEbus Interrupt Control register. When the programmable clock generator is enabled, periodic interrupts are broadcast. The Broadcast Programmable Clock Timer register (see [Section 10.4.68 on page 309](#)) is used to program the interrupt rate.

64-bit Counter

There is a 64-bit counter which can be incremented by a signal on the IRQ[1]_ or IRQ[2]_ signal line. In this mode, one board transmits a clock on either the IRQ[1] or IRQ[2] signal lines and the receiving boards use this clock signal to increment their 64-bit counter. This feature provides a reference counter that is synchronized on all the boards.

The transmitting board can also be a receiving board. The clock can be derived from the programmable clock generator or the 0.98 MHz clock. When the 0.98 MHz clock is used, the 64-bit counter can provide a unique time stamp every 1.02 μ s.

2.3.6.5 SYSFAIL Operation

For more information on SYSFAIL functionality refer to [Section 5.4.2 on page 130](#).

2.3.6.6 VMEbus Configuration

For more information on VMEbus configuration refer to [Section 5.4.2 on page 130](#).

2.3.7 Tsi148 as a VMEbus System Controller

The Tsi148 supports the following system controller functions:

- VMEbus Arbiter with three modes of programmable arbitration:
 - Priority (PRI)
 - Round-Robin-Select (RRS)
 - Single Level (SGL)
- IACK Daisy-Chain Driver
- SYSRESET Driver: Provides a global system reset
- Global VMEbus Timer: Monitors the VMEbus and generates a BERR_ when there is no VMEbus activity for the programmed value
- System Clock Driver: Generates a 16 MHz system clock

2.3.7.1 Arbiter

The Tsi148 VMEbus arbiter is programmable. All three of the following arbitration modes defined by the VMEbus standard are supported:

- Priority (PRI)
- Round-Robin-Select (RRS)
- Single Level (SGL)

A 16 us arbitration timer is included in the Tsi148 to prevent a bus lock-up from occurring when no requester assumes mastership of the bus after the arbiter has issued a grant. This timer can be enabled or disabled in the VMEbus Control and Status Register (see [Section 10.4.34 on page 257](#)).

2.3.7.2 IACK Daisy-Chain Driver

An IACK Daisy-Chain driver is included in the Tsi148 as part of the system controller functionality. This feature ensures that the timing requirements for starting the IACK Daisy-Chain are satisfied.

2.3.7.3 SYSRESET Driver

A SYSRESET driver is included in the Tsi148 to provide a global system reset. The SRSTO signal is asserted in the following cases: the LSRSTI_ pin is asserted, the SRESET bit is asserted in the VMEbus Control Status Register, or the PURSTI_ pin is asserted. The SRSTO signal is always asserted for at least 200 ms. SRSTO is normally connected to the VMEbus SYSRESET_ signal through an inverting open collector buffer.

2.3.7.4 Global VMEbus Timer

The Tsi148 has a VMEbus global timer that monitors VMEbus cycles and generates a BERR signal when there is no VMEbus slave response for the programmed time period. The global timer only monitors VMEbus cycles when the system controller function is enabled. The global timer is compatible with SCT, BLT, MBLT, 2eVME, and 2eSST transfers. The global time-out period can be programmed for 8, 16, 32, 64, 128, 256, 512, 1024, 2048 μ s. This timer can be enabled or disabled in the VMEbus Control and Status Register (see [Section 10.4.34 on page 257](#)).

2.3.7.5 System Clock Driver

Tsi148 generates the system clock (SYSCLK) signal when it is configured as the system controller. The SYSCLK signal is in spec for the following PCI/X clock frequencies: 33.3, 66.6, 100, or 133 MHz. The SYSCLK pin is connected through an external driver to the VMEbus. SYSCLK operates at 16 MHz. The external driver is enabled through the SCON pin (see [Section 8.4.2 on page 161](#)).

2.3.7.6 Configuration

The system controller functions can be configured at power-up. The system controller functionality can be enabled or disabled, or the auto system controller (SCON) function can be used. The auto SCON function automatically enables the system controller functions when the board is installed in slot 1. [Table 10 on page 135](#) shows the different signal combinations that enable or disable the SCON functionality.

3. PCI/X Interface

This chapter describes the main features and functions of the Tsi148™. The following topics are discussed:

- “Overview of the PCI/X Interface” on page 72
- “PCI Mode” on page 72
- “PCI-X Mode” on page 86

3.1 Overview of the PCI/X Interface

The PCI/X interface can be configured to operate in PCI mode or PCI-X mode. PCI-X mode is described in [Section 3.3 on page 86](#).

3.2 PCI Mode

Tsi148 is compliant with the *PCI Local Bus Specification (Revision 2.2)*.

3.2.1 PCI Target

The PCI Target supports the PCI protocol, 32-bit and 64-bit data transfers, and 32-bit and 64-bit addresses.

The PCI Target supports configuration cycles to PCI configuration registers and memory space accesses. The Linkage Module provides access to the Combined Register Group (CRG) and the VMEbus (see [Section 10.1 on page 196](#) for more register information). The VME Master provides the interface between the Linkage Module and the VMEbus.

The PCI Target does not respond to PCI I/O transfers.

3.2.1.1 PCI Target Buffers

The PCI Target shares buffers between the PCI and PCI-X protocols. When the PCI/X bus is configured for PCI mode, only 512 bytes of the 4 Kbyte read buffer can be used. The read buffer is segmented into two parts: a data queue and a command queue. The command queue stores address and command information from the PCI bus and can accept one delayed transaction. The data queue stores up to 512 bytes of data.

The PCI Target stores the address and command information in the command queue when servicing a read request from the PCI bus master. The amount of data pre-fetched and stored in the read buffer is determined by the read command (see [Table 3 on page 76](#)).

The write buffer receives data and commands from the PCI bus. The write buffer is segmented into two parts: data queue and command queue. The 4 Kbyte data queue is designed for large, burst transfers. The command queue stores address and command information and can accept up to 40 entries. The write buffer is full when either the command or data queue is full.

3.2.1.2 Transaction Mapping

The PCI bus is capable of many different transaction types, including: single beat transactions, burst transactions, each with flexible byte enable patterns. These transactions must be mapped to corresponding transactions on the VMEbus. There are many different modes and protocols supported by the VMEbus and the numerous programmable options. The following rules can be applied to transactions:

- Writes
 - During a PCI bus write, the selected bytes on the PCI bus maps directly to the destination bus. The chip does not write to bytes on the destination bus that are not selected on the PCI bus.
- Reads
 - Single byte reads on PCI maps to a single byte read on the destination bus. If the PCI Master inserts initial wait states during a read transaction (IRDY_ is not asserted one clock after FRAME_), the transaction is a burst and the PCI Target prefetches data from the VMEbus based on the programming in the Outbound Translation Attribute register (see [Section 10.4.26 on page 243](#)).
 - Read line and read multiple commands from a PCI Master causes data to be prefetched from the VMEbus based on the programming in the Outbound Translation Attribute Register.



Any locations with read sensitive bits should be accessed using a byte read or a read that matches the width of the location. There is a one-to-one correspondence between the bytes written on the PCI bus and bytes written on the destination bus. PCI bus writes with byte holes do not result in writes to the non-selected bytes.

- The PCI Target does not merge, combine, or gather transactions. Because of the different bus widths, a single beat transaction on the PCI bus may map to a multi beat transaction on the destination bus. A transaction that completes in a single bus tenure on the PCI bus may not complete in a single bus tenure on the destination bus.

PCI-to-VME Address Mapping

The PCI Target has eight programmable PCI bus target images which map PCI transactions to VME address space.

The PCI Target maps a PCI address to the destination address space using eight programmable target images. These target images provide windows into the VMEbus from the PCI bus. The PCI address is compared with the address range of each target image, and if the address falls within the specified range, an offset is added to the incoming address to form the destination address.

The incoming address is within the target images window if the incoming address is greater than or equal to the starting address and less than or equal to the ending address.



All programmable target images should decode unique address ranges. However, if the target images overlap, slave image zero has the highest priority and slave image seven has the lowest priority.

Figure 10 shows the programmable starting address, ending address, and translation offset.

Figure 10: PCI Target Image Programmable Address Offset

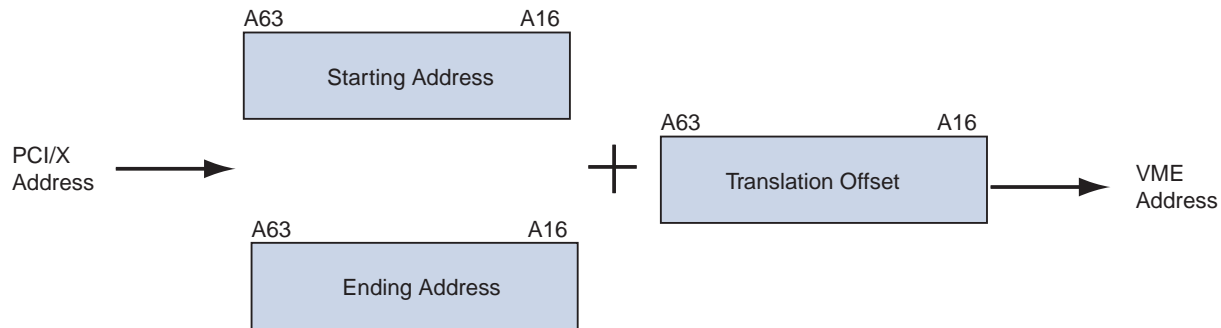

3.2.1.3 PCI Transactions

All transactions through the PCI Target are completed on the VMEbus in the same order that they are completed on the PCI bus. A read transaction forces all previously issued posted write transactions to be flushed from the buffers. All posted write transfers are completed before a read is begun to make sure that all transfers are completed in the order issued. For more information on transaction mapping, refer to [Section 3.2.1.2 on page 73](#).

Commands

The PCI Target responds to the following PCI bus commands:

- Memory read
- Memory write
- Configuration read
- Configuration write
- Memory read multiple
- Dual address cycle
 - 64-bit address transactions
- Memory read line
- Memory write and invalidate

PCI Read Transaction

During a read, the PCI Target uses delayed transactions. Delayed read transactions are used in order to free the PCI bus from waiting for the potentially long VMEbus arbitration and transfer. The PCI Target supports one delayed read transaction. Tsi148 manages the completion of the read transaction on the VMEbus.

When the PCI Target receives a read request, the PCI Target saves the information required to complete the transfer and then retries the PCI bus master. This allows the PCI bus to be used by other PCI bus masters while Tsi148 completes the transfer. The PCI Target continues to retry the PCI bus master until the VMEbus transfer has been completed. If any other PCI bus masters try to use the PCI Target, they are retried. If the read transfer completes on the VMEbus and the PCI master does not return within 2^{15} PCI bus clocks, the read data is discarded (flushed) and the transfer is terminated. The PCI Target uses its 512 byte data queue for storing prefetched read data. A prefetch read does not extend past the ending address defined by the PCI Target Image (see [Section 10.4.20 on page 237](#)).

The PCI bus command and PCI FRAME_ signal are used to define how much data to read from the VMEbus. If FRAME_ is asserted for a single clock, the transfer is considered to be a single beat transfer (regardless of the PCI command). In this case, a single beat read command is passed to the Linkage Module. If FRAME_ is asserted for more than one clock, the transfer is considered a burst transfer and the data size depends on the PCI bus command, and the programming of the Memory Read Prefetch Disable (MRPFD) bit and the Prefetch Size (PFS) field of the Outbound Translation Attribute (OTAT_x) registers (see [Section 10.4.26 on page 243](#)).



The size of a single beat read command depends on the size of the PCI bus. If the PCI bus is 32-bit the single beat read command transfers 4 bytes, on a 64-bit bus the command transfers 8 bytes.

If the PCI bus request is a memory read burst transfer, and the MRPFD bit is clear, the read command passed to the Linkage Module requests 32 bytes (see [Table 3](#)). If the MRPFD bit is set, a single beat read command is passed to the Linkage Module.

When a PCI bus memory read line burst transfer is received, the read command passed to the Linkage Module requests 32 bytes. When a PCI bus memory read multiple command is received, the data size depends on the PFS bits. The read sizes are 64, 128, 256, or 512 bytes. The PCI read operations are summarized in [Table 3](#).

Table 3: PCI Read Data Size

PCI Transfer	PCI Command	MRPFD Bit	PFS Bits	Linkage Command
Single Beat	X	X	X	Single Beat
Burst	Read	1	X	Single Beat
Burst	Read	0	X	32 bytes
Burst	Read Line	X	X	32 bytes
Burst	Read Multiple	X	0	64 bytes
Burst	Read Multiple	X	1	128 bytes
Burst	Read Multiple	X	2	256 bytes
Burst	Read Multiple	X	3	512 bytes

The PCI bus master is retried until all the requested data is available in the PCI Target read buffer. The read then completes on the PCI bus.



Care must be used when setting the value in the PFS field because the VMEbus read is completed before data is transferred on the PCI bus. If the value is too large, time is wasted reading data that is not used. If the value is too small, additional PCI bus commands are required. The optimum setting depends on the PCI bus masters and the requirements of the application. In many cases, the only read transfers from the PCI bus to the VMEbus are single beat processor load operations and prefetching is not required.

Example PCI Read Transaction

In this example read, the transaction is separated into Request and Completion phases. The following list, and [Figure 11](#) and [Figure 12](#), show the steps taken in the first part of the transaction, Request, and in the second part of the transaction, Completion.

1. A PCI bus master initiates a read request to a VME peripheral

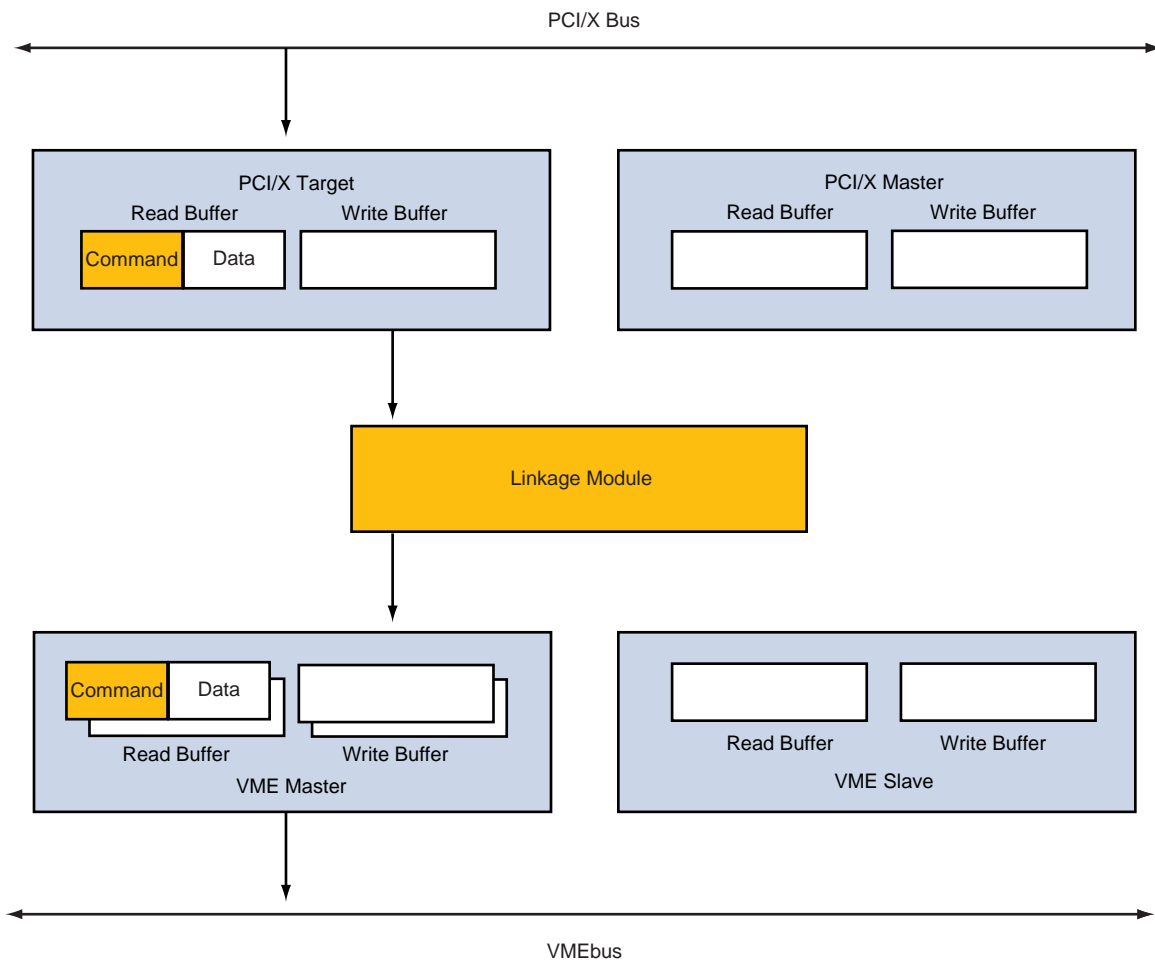
Figure 11: PCI-VME Delayed Read Request

2. The Tsi148 PCI Target decodes the request and issues a retry to the PCI bus master
3. The PCI Target stores the command and address information in the PCI Target's read buffer command queue
 - Tsi148 supports one delayed read request
4. The PCI Target makes a read request to the Linkage Module

- **Table 3** describes the PCI bus read commands and the parameters which define the command that is passed to the Linkage Module



The Linkage Module provides a common interface for all the modules and has the following ports: VMEbus, PCI bus, DMA 0, DMA1, and registers. The Linkage Module uses a round-robin arbitration scheme to fairly arbitrate between the ports.

5. After arbitration, the Linkage Module command and address information is passed to one of the VME Master's read buffer command queues.
6. The VME Master issues the read request to the VMEbus slave.
7. The VMEbus slave satisfies the read request and the data is stored in one of the two 4 Kbyte VME Master's read buffer data queues.



Having two buffers to store data allows the Tsi148 VME Master to do back-to-back reads on the VMEbus.

8. When the read request is satisfied and the data is queued in the VME Master's data buffer, the VME Master makes a return request to the Linkage Module.

Figure 12: PCI-to-VME Delayed Read Completion

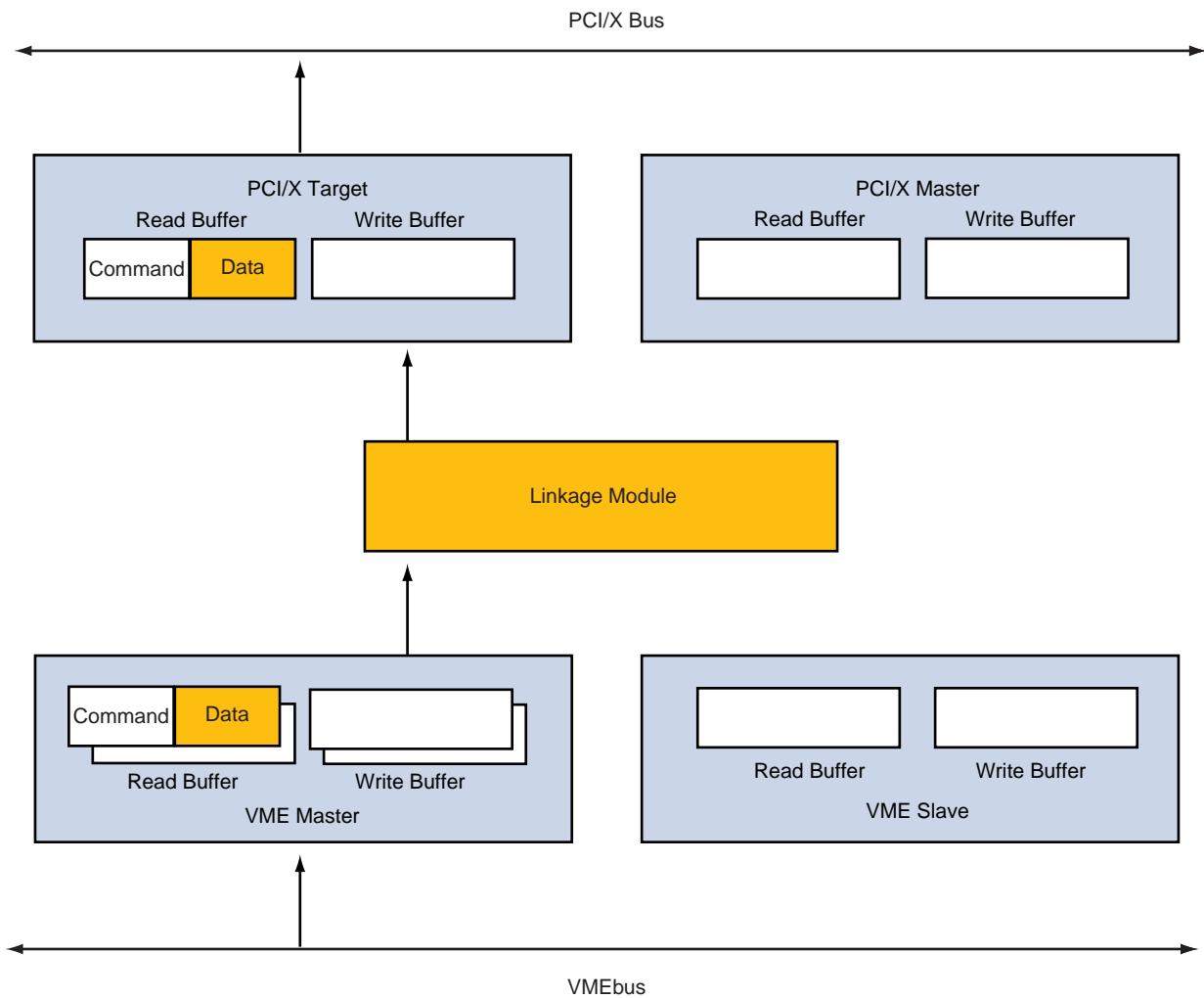

9. After Linkage Module arbitration, the read data is passed through the Linkage Module to the PCI Target's read buffer data queue.
10. Once the entire read request is queued in the PCI Target's read buffer data queue the initial read request can be satisfied on PCI.
 - If the initiating PCI bus master makes a request for the data before the full request is satisfied in the read buffer data queue, Tsi148 retries the PCI bus master.

Write Transaction

During write transactions, the external master writes data into the PCI Target write buffer. All writes are posted. The buffer stores the data necessary to complete a PCI write transfer and immediately acknowledges the transaction on the PCI bus. Acknowledging the transaction frees the PCI bus from waiting for the potentially long VMEbus arbitration and transfer. This allows the PCI bus to be used by other PCI bus masters while Tsi148 completes the posted write transaction on the VMEbus. If the posted write buffer is full, the PCI Target retries the PCI bus master until there is space available in the write buffer.

The PCI Target write buffer includes a 40 deep command queue and a 4 Kbyte data queue. The PCI Target write buffer stores the commands and data in any combination of single and burst transactions. When a transfer is completed on the PCI bus, the data is transferred to the Linkage Module.

Example PCI Write Transaction

In this example posted write transaction, the transaction completes in one phase through the device. The following list, and **Figure 13**, show the steps taken in the transaction.

1. An external PCI bus master initiates a write to a VMEbus slave.

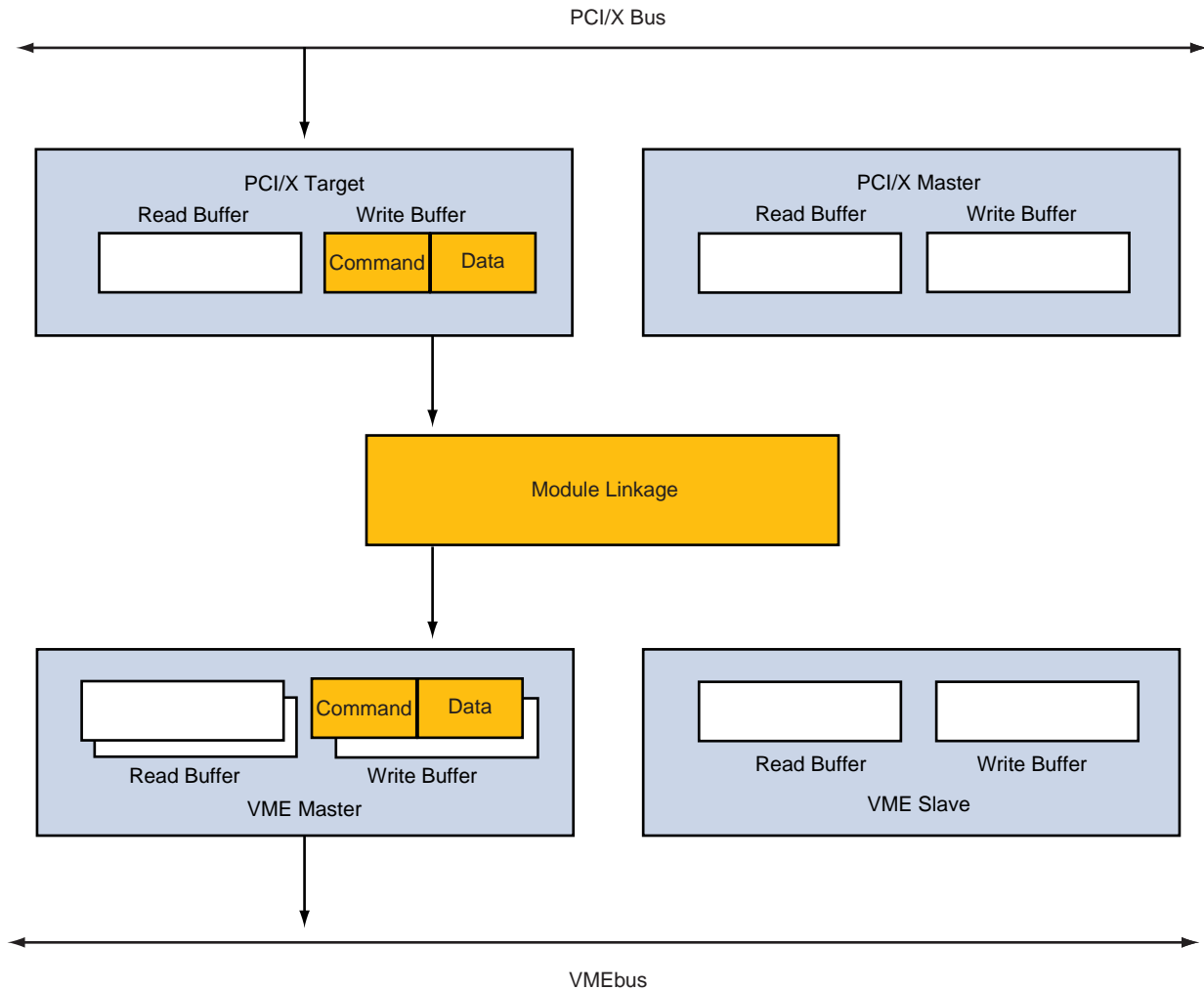
Figure 13: PCI-to-VME Posted Write

2. The PCI Target puts the address and command information in its command queue
 - All write transactions are posted within the PCI Target's write buffer data queue. The PCI Target's write buffer data queue is 4 Kbytes.
3. The PCI Target puts the corresponding data into its data queue
4. The PCI Target accepts write data until the write buffer fills or the transaction ends.
5. The PCI Target then sends a transaction request to the Linkage Module.

6. After arbitration, the Linkage Module passes the command information, address information, and the write data to one of the VME Master's write buffers.



Having two write buffers allows the VME Master to accept two write transactions from the Linkage Module.

7. The VME Master completes the write transaction to the addressed VMEbus slave.

Transaction Terminations

The PCI Target can terminate a transaction with a retry or a disconnect. The PCI Target terminates the transaction with a retry in the following cases:

- The transaction is a memory write and the PCI Target write buffer is full
- The transaction is the first transaction of a memory read
- The transaction is a memory read that does not match a pending memory read
- The transaction is a memory read that matches a pending memory read but the data is not available

The PCI Target terminates the transaction with a disconnect in the following cases:

- A write with byte holes is received and the Stop on Byte Holes (SBH) bit in the PCI Control Register is set (see [Section 10.4.36 on page 263](#))
- A transfer reaches the end of a PCI Target image
- The burst ordering is non-linear
- A burst read requires more data than was prefetched
- A write burst fills the PCI Target write buffer



The Tsi148 PCI Target never terminates a transaction with a Target-abort.

3.2.2 PCI Master

The PCI Master provides the interface between Linkage Module and the PCI bus. The PCI Master supports a 32-bit and 64-bit data bus and 32-bit and 64-bit addresses.

3.2.2.1 PCI Master Commands

The PCI Master can generate the following PCI bus commands:

- Memory read: A memory read command is used when the requested byte count is less than or equal to 4 bytes.
- Memory read multiple: The memory read multiple command is used when the requested byte count is greater than 32 bytes.
- Memory read line: A memory read line command is used when the requested byte count is greater than 4 bytes and less than or equal to 32 bytes.
- Memory write
- Dual address cycle: A dual address cycle is generated when the PCI address is greater than 32-bits.

3.2.2.2 PCI Master Buffers

The PCI Master has one read buffer and one write buffer. The buffers are segmented into two parts: a data queue and a command queue. Both the read and write buffer command queues are six entries deep. The read buffer data queue is 512 byte while the write data buffer is 4 Kbyte.

The read buffer stores Linkage Module commands when servicing a read request from the VMEbus to the PCI bus. The PCI Master requests the PCI bus when it receives a read command from the Linkage Module. After the read transaction has been satisfied on the PCI bus, and the PCI read buffer data queue has the requested data, the PCI Master transfers the data through the Linkage Module to the VMEbus.

The write buffer stores Linkage Module commands and data. The PCI Master requests the PCI bus when it receives write data from the Linkage Module. The write buffer is considered full when either the command queue or data queue is full.

3.2.2.3 PCI Master Bandwidth Control

The PCI bus latency timer can be used to control the PCI bus bandwidth used by Tsi148. The PCI Master requests the PCI bus when it has a transaction to complete (for example, when the PCI Master receives a command from the Linkage Module or when the master needs to complete a previously received command). The PCI Master maintains mastership of the PCI bus until the Linkage Module command is completed or until the PCI bus grant is removed and the latency timer has expired.

3.2.3 PCI Bus Exception Handling

Tsi148 includes error diagnostic registers which capture information when an error occurs. The information captured includes the PCI bus address and command (see [Section 10.4.41 on page 274](#)). The error diagnostic registers are updated when the first error occurs. If another error occurs before software has examined the registers, the information is not captured and the overflow bit is set.

The following list details the error diagnostic registers in Tsi148:

- Error Diagnostic PCI Address Upper (EDPAU)
- Error Diagnostic PCI Address Lower (EDPAL)
- Error Diagnostic PCI Attributes (EDPAT)

3.2.3.1 PCI Master Exception Handling

The error diagnostic registers are updated when Tsi148 is PCI Master and one of the following errors occurs: the master retry count is exceeded (programmed in the PCI Control / Status Register, see [Section 10.4.36 on page 263](#)), a Master-abort or Target-abort is received.



The Tsi148 interrupt controller can be programmed to generate an interrupt when the exception registers are updated.

When the PCI Master receives a Master-abort, Target-abort, or the maximum count is exceeded the following steps are taken:

- Returns all FFs on VMEbus with the DTACK signal
- Log status information and update PCI bus error diagnostic registers
- Optional step: generate interrupt

When the PCI Master detects a data parity error the following steps are taken:

- Generate PERR (if enabled)
- Log status information and update PCI bus error diagnostic registers
- Optional step: generate interrupt

3.2.3.2 PCI Target Exception Handling

The error diagnostic registers are updated when the PCI Target detects an address parity error, a data parity error, or a delayed transaction time-out occurred.

When the PCI Target detects a address parity error the following steps are taken:

- Generate SERR (if enabled)
- Log status information

When the PCI Target detects a data parity error the following steps are taken:

- Generate PERR (if enabled)
- Log status information and update PCI bus exception registers
- Optional step: generate interrupt

When the PCI Target detects a delayed transaction time-out the following steps are taken:

- Discard Data
- Log status information and update PCI bus exception registers
- Optional step: generate interrupt

If the PCI Target detects the assertion of the SERR_ signal, no action is taken.

3.3 PCI-X Mode

Tsi148 is compliant with the *PCI-X Addendum to PCI Local Bus Specification (Revision 1.0b)*.

3.3.1 PCI-X Target

The PCI-X Target supports 32-bit and 64-bit data transfers and 32-bit and 64-bit addresses.

The PCI-X Target supports configuration cycles to PCI-X configuration registers and memory space accesses. The Linkage Module provides access to the combined register group and the VMEbus. The VME Master provides the interface between the Linkage Module and the VMEbus.

The PCI-X Target does not respond to PCI-X I/O transfers.

3.3.1.1 PCI-X Target Buffers

The PCI-X Target shares buffers between the PCI and PCI-X protocols. When the PCI-X bus is configured for PCI-X mode, the entire 4 Kbyte PCI-X Target read buffer can be used. The read buffer is segmented into two parts: a data queue and a command queue. The command queue stores address and attributes from the PCI-X bus and can accept up to six split transactions. The data queue stores up to 4 Kbyte of data.

The PCI-X Target read buffer stores the address and attributes of the transaction in the command queue when servicing a read request from the PCI-X bus master. The requested data comes from the VMEbus, through Linkage Module, to the PCI-X Target read buffer data queue. The amount of data in read buffer depends on the requested byte-count in the attribute phase of the PCI-X transaction.

The write buffer receives data and commands from the PCI-X bus. The write buffer segmented into two parts: data queue and command queue. The 4 Kbyte data queue is designed for large, burst transfers. The command queue stores address and attributes from PCI-X transactions and can accept up to 40 entries. The write buffer is full when either the command or data queue is full.

3.3.1.2 Transaction Mapping

The PCI-X bus is capable of many different transaction types, including: single beat transactions, burst transactions, each with flexible byte enable patterns. These transactions must be mapped to corresponding transactions on the VMEbus. There are many different modes and protocols supported by the VMEbus and the numerous programmable options. The following rules can be applied to transactions:

- Writes
 - During a PCI-X bus write, the selected bytes on the PCI-X bus map directly to the destination bus. The Tsi148 does not write to bytes on the destination bus that are not selected on the PCI-X bus.
 - During a PCI-X bus memory write block, the number of bytes in the byte count, along with the starting address map directly to the destination bus.
- Reads
 - The PCI-X bus protocol includes a byte count. The number of bytes requested from the destination bus generally matches the byte count requested by the PCI-X bus master.



Any locations with read sensitive bits should be accessed using a byte read or a read that matches the width of the location (preferably the memory read DWORD command). There is a one-to-one correspondence between the bytes written on the PCI-X bus and bytes written on the destination bus.

- The PCI-X Target does not merge, combine, or gather transactions. Because of the different bus widths, a single beat transaction on the PCI-X bus may map to a multi beat transaction on the destination bus. A transaction that completes in a single bus tenure on the PCI-X bus may not complete in a single bus tenure on the destination bus.

PCI-X-to-VME Address Mapping

The PCI-X Target has eight programmable PCI-X bus target images which map PCI-X transactions to VME address space.

The PCI-X Target maps a PCI-X address to the destination address space using eight programmable target images. These target images provide windows into the VMEbus from the PCI-X bus. The PCI-X address is compared with the address range of each target image, and if the address falls within the specified range, the offset is added to the incoming address to form the destination address.

The incoming address is within the target images window if the incoming address is greater than or equal to the starting address and less than or equal to the ending address.



All programmable target images should decode unique address ranges. However, if the target images overlap, slave image zero has the highest priority and slave image seven has the lowest priority.

Figure 14 shows the programmable starting address, ending address, and translation offset.

Figure 14: Target Image Programmable Address Offset

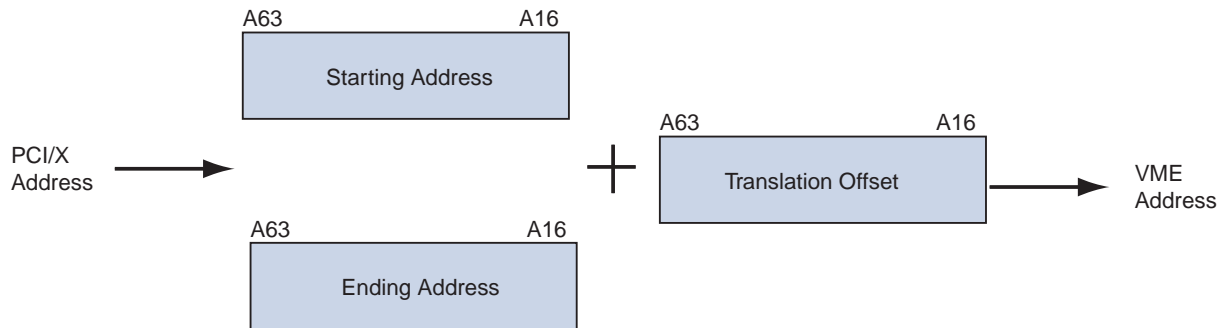

3.3.1.3 PCI-X Transactions

All transactions through the PCI-X Target are completed on the VMEbus in the same order that they are completed on the PCI-X bus. A read transaction forces all previously issued posted write transactions to be flushed from the buffers. All posted write transfers are completed before a read is begun to make sure that all transfers are completed in the order they are issued. For more information on transaction mapping, refer to [Section 3.3.1.2 on page 87](#).

Commands

The PCI-X Target responds to the following PCI-X bus commands:

- Memory read DWORD
- Memory write
- Configuration read
- Configuration write
- Split completion
- Dual address cycle
- Memory read block
- Memory write block

PCI-X Read Transaction

The PCI-X Target uses split read transactions for all reads, which frees the PCI/X bus from waiting for the potentially long VMEbus arbitration and transfer. Tsi148 supports up to six split reads.



For more information on the PCI-X implementation of split reads, refer to the *PCI-X Addendum to PCI Local Bus Specification (Revision 1.0b)*.

When the PCI-X Target receives a read request, the PCI-X Target saves the information required to complete the transfer and then issues a Split Response termination to the PCI-X bus master. This allows the PCI-X bus to be used by other PCI-X bus masters while Tsi148 completes the transfer. If the PCI-X Target receives a read request from a PCI-X bus master and the PCI-X Target read buffer command queue is full, the PCI-X Target retries the PCI-X bus master until there is space available in the read buffer.



A Split Response means PCI-X Target does not have to issue retries as the read is being completed on the VMEbus while waiting for the requested data.

After the PCI-X Target has issued the Split Response to the PCI-X bus master, the PCI-X Target then issues a read command to the Linkage Module for the requested byte count. As defined in the *PCI-X Addendum to PCI Local Bus Specification (Revision 1.0b)*, byte counts up to 4 Kbyte are supported.

When the data is returned from the VME Master through the Linkage Module to the PCI-X Target read buffer, the Tsi148 PCI-X Master initiates a Split Completion and transfers the data from the PCI-X Target read buffer to the requesting PCI-X bus master. If the requested read extends past the ending address defined by the Target Image (see [Section 10.4.20 on page 237](#)), the PCI-X Master provides data up to the end of the image and then terminates the transaction with a Split Completion Error Message to the initiating PCI-X bus master (see [Section 3.3.3.1 on page 97](#)).

Example PCI-X Read Transaction

In this example PCI-X-to-VME read, the transaction is separated into Request and Completion phases. The following list, and **Figure 15**, show the steps taken in the first part of the transaction (Request). The second part of the list, and **Figure 16**, shows the next part of the transaction (Completion).

1. A PCI-X master initiates a read request to a VMEbus slave

Figure 15: PCI-X-to-VME Delayed Read Request

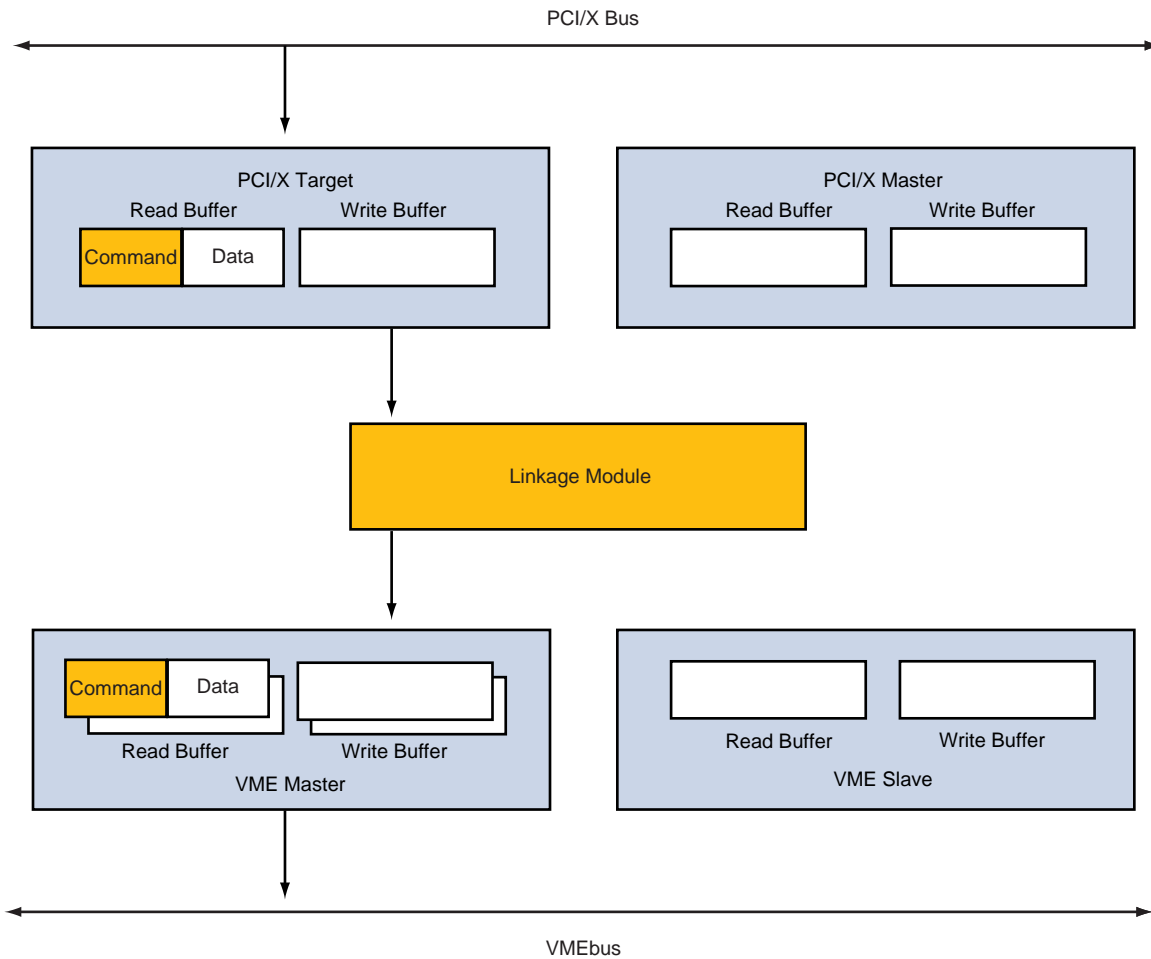

2. The Tsi148 PCI-X Target decodes the request and issues a Split Response termination to the initiating PCI-X bus master
3. The PCI-X Target stores the command, address, and attribute information in the PCI-X Target's read buffer command queue
 - Tsi148 supports up to six split read transactions

4. The PCI-X Target sends a read request to the Linkage Module with the VME address information and required byte count

— Tsi148 supports byte counts of up to 4 Kbytes



The Linkage Module provides a common interface for all the modules. The Linkage Module interface has the following ports: VMEbus, PCI bus, DMA 0, DMA1, and registers. The Linkage Module uses a round-robin arbitration scheme to fairly arbitrate between the ports.

5. After arbitration, the Linkage Module command and address information is passed to a VME Master read buffer command queue.
6. The VME Master issues the read request to the VMEbus slave.
7. The VME Slave satisfies the read request and the data is stored in one of the two, 4 Kbyte VME Master read buffer data queues.



Having two buffers to store data allows the Tsi148, through the VME Master, to do back-to-back reads on the VMEbus.

8. Once the full byte count of the read request is satisfied and the data is queued in a VME Master's buffer, the VME Master makes a return request to the Linkage Module.

Figure 16: PCI-X-to-VME Delayed Read Completion

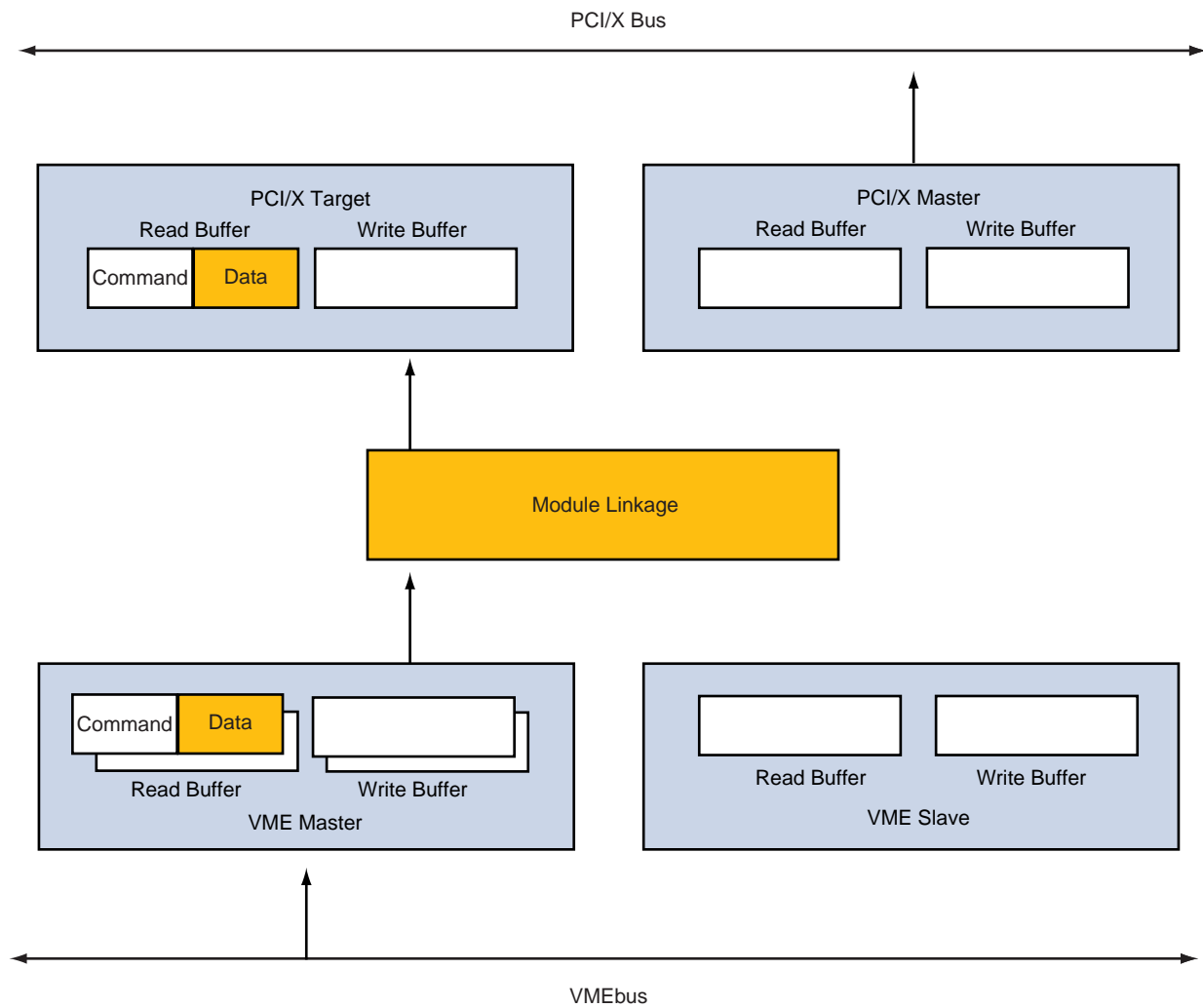

9. After Linkage Module arbitration, the read data is passed through the linkage to the PCI-X Target read buffer data queue.
10. Once the entire read request is queued in the PCI-X Target's read buffer data queue, Tsi148 issues a Split Completion through the PCI-X Master onto the PCI-X bus to the original, initiating PCI-X bus master.
11. The PCI-X Master transfers the data from the PCI-X Target's read buffer data queue to the PCI-X bus master.

3.3.1.4 PCI-X Write Transaction

During write transactions, the external master writes data into the PCI-X Target write buffer. All writes are posted and the buffer stores the data necessary to complete a PCI-X write transfer and immediately acknowledges the transaction on the PCI-X bus. Acknowledging the transaction frees the PCI-X bus from waiting for the potentially long VMEbus arbitration and transfer. This allows the PCI-X bus to be used by other PCI-X bus masters while Tsi148 completes the posted write transaction on the VMEbus. If the posted write buffer is full, the PCI-X Target retries the PCI-X bus master until there is space available in the write buffer.

The PCI-X Target write buffer has a 40 entry command queue and a 4 Kbyte data queue (see [Section 3.3.1.1 on page 86](#)). The PCI-X Target buffer stores the commands and data in any combination of single and burst transactions. When a transfer is completed on the PCI-X bus, the data is transferred to the Linkage Module. If the PCI-X Target receives a write command that extends past the space programmed in the Target Image, the PCI-X Target accepts the data up to the end of the Target Image and then issues a Disconnect.

Example PCI-X Write Transaction

In this example PCI-X-to-VME write transaction, the data passes through Tsi148 through the PCI-X Target, to the Linkage Module, and ends at the VME Master. The following list, and **Figure 17**, show the steps taken in the write transaction.

1. A PCI-X master initiates a write to a VMEbus slave.

Figure 17: PCI-X-to-VME Posted Write

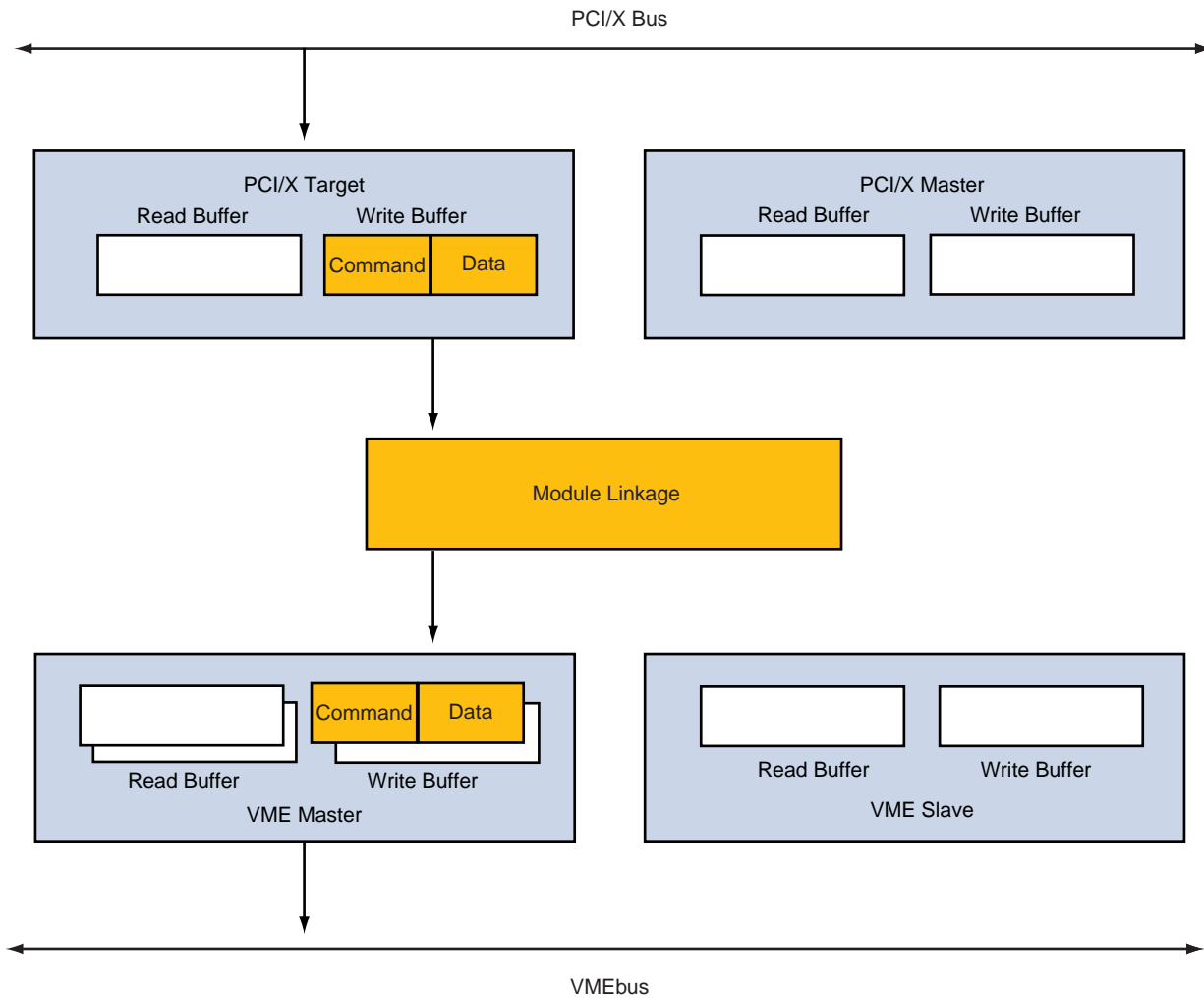

2. The PCI-X Target puts the address and command information in its write buffer command queue
 - All write transactions are posted within the PCI-X Target write buffer data queue. The PCI-X Target write buffer data queue is 4 Kbytes.
3. The PCI-X Target puts the corresponding data into its data queue

4. The PCI-X Target accepts write data until the write buffer fills or the transaction ends.
5. The PCI-X Target then sends a transaction request to the Linkage Module.
6. After arbitration, the Linkage Module passes the command information, address information, and the write data to a VME Master write buffer.



Having two sets of write buffers allows the VME Master to accept two write commands and data from the Linkage Module.

7. The VME Master completes the write transaction to the addressed VMEbus slave.

3.3.1.5 Transaction Termination

The PCI-X Target can terminate a transaction with many of the terminations defined in the *PCI-X Specification*. For read requests, PCI-X Target uses split read terminations.

The PCI-X Target terminates a transaction with a retry in the following cases:

- The transaction is a memory write and the write buffer is full.
- The transaction is a read and the read buffer command queue is full

The PCI-X Target terminates a transaction with a disconnect on an *address data boundary* (ADB) in the following cases:

- A transfer reaches the end of a target image
- A burst write fills the write buffer

3.3.2 PCI-X Master

The PCI-X Master can generate the following PCI-X bus commands:

- Split completion
- Dual address cycle (A dual address cycle is generated when the PCI address is greater than 32 bits)
- Memory read block
- Memory write block

3.3.2.1 PCI-X Master Buffers

The PCI-X Master has one read buffer and one write buffer. The buffers are segmented into two parts: a data queue and a command queue. Both the read and write buffer command queues are six entries deep. The read and write data buffers are 4 Kbyte.

The read buffer stores Linkage Module commands when servicing a read request from the VMEbus to the PCI-X bus. The PCI-X Master requests the PCI-X bus when it receives a read command from the Linkage Module. After the read transaction has been satisfied on the PCI-X bus, and the read buffer data queue has the requested data, the PCI-X Master transfers the data through the Linkage Module to the VMEbus.

The write buffer stores Linkage Module commands and data. The PCI-X Master requests the PCI-X bus when it receives a command and write data from the Linkage Module. The write buffer is considered full when either the command or data queue is full.

3.3.2.2 PCI-X Master Bandwidth Control

The PCI-X bus latency timer can be used to control the PCI-X bus bandwidth used by Tsi148. The PCI-X Master requests the PCI-X bus when it has a transaction to complete (for example, when the PCI-X Master receives a command from the Linkage Module or when it needs to complete a previously received command). The PCI-X Master maintains mastership of the PCI-X bus until the linkage command is completed or until the PCI-X bus grant is removed and the latency timer has expired.

3.3.3 PCI-X Bus Exception Handling

Tsi148 includes error diagnostic registers which capture information when an error occurs. The information captured includes the PCI-X bus address, attribute, and command (see [Section 10.4.43 on page 276](#)). The error diagnostic registers are updated when the first error occurs. If another error occurs before software has examined the registers, the information is not captured and the overflow bit is set.

The following list details the error diagnostic registers in Tsi148:

- Error Diagnostic PCI Address Upper (EDPAU)
- Error Diagnostic PCI Address Lower (EDPAL)
- Error Diagnostic PCI-X Attribute (EDPXA)
- Error Diagnostic PCI-X Split Completion Message (EDPXS)
- Error Diagnostic PCI Attributes (EDPAT)

For more information on Tsi148 error diagnostic registers, refer to [Section 10.4.43 on page 276](#).

3.3.3.1 PCI-X Master Exception Handling

The error diagnostic registers are updated when Tsi148 is PCI-X Master and one of the following errors occurs: the master retry count is exceeded, a split response time-out occurs, split completion error asserted, or a Master-abort or Target-abort is received.



The Tsi148 interrupt controller can be programmed to generate an interrupt, when the exception registers are updated.

When the PCI-X Master receives a Master-abort, Target-abort, or the maximum retry count is exceeded the following steps are taken:

- Return FF's on VMEbus with the DTACK signal
- Log status information and update PCI-X bus exception registers (see [Section 10.4.43 on page 276](#))
- Optional step: generate interrupt

When the PCI-X Master detects a data parity error the following steps are taken:

- Generate PERR (if enabled)
- Log status information and update PCI-X bus exception registers (see [Section 10.4.43 on page 276](#))
- Optional step: generate interrupt

3.3.3.2 PCI-X Target Exception Handling

The error diagnostic registers are updated when the PCI-X Target detects an address parity error, a data parity error has occurred, or a unexpected split completion is received.

When the PCI-X Target detects a address parity error the following steps are taken:

- Generate SERR (if enabled)
- Log status information

When the PCI-X Target detects a data parity error the following steps are taken:

- Generate PERR (if enabled)
- Log status information and update PCI-X bus exception registers (see [Section 10.4.43 on page 276](#))
- Optional: step generate interrupt

When the PCI-X Target receives an unexpected split completion the following steps are taken:

- The split completion is discarded and the Split Completion Discarded (SCD) bit is set in the Error Diagnostic PCI Attribute register (see [Section 10.4.43 on page 276](#)).



If the PCI-X Target detects the assertion of the SERR_ signal, no action is taken.

4. DMA Interface

Direct memory access (DMA) allows a transaction to occur between two devices without involving the host processor (for example, a read transaction between a peripheral device and host processor memory). Because less time is required to complete transactions, applications that contain one or more DMA channels support faster read and write transfers than applications that support only host-assisted transactions.

This chapter discusses the following topics about the Tsi148 DMA:

- [“Overview DMA Controller” on page 100](#)
- [“Architecture” on page 100](#)
- [“DMA Buffers” on page 100](#)
- [“Operating Modes” on page 101](#)
- [“Direction of Data Movement” on page 104](#)

4.1 Overview DMA Controller

The Tsi148 has two independent, single channel DMA controllers that enable the transfer of large blocks of data without processor intervention. Each DMA controller is programmed by a set of registers that reside within the LCSR group (see [Section 10.2.3 on page 197](#)).



The Combined Register Group (CRG) map decoder can be programmed to allow access to the control registers from the VMEbus.

Each DMA controller supports 64-bit addressing on the VMEbus and the PCI/X bus. The amount of data moved during a command is only limited by the 32-bit byte counter, allowing transfer counts to range from 1 byte to 4 Gbytes.

4.2 Architecture

Each DMA controller connects to the Linkage Module and uses the PCI/X Master and VME Master to transfer data. The core of the DMA controller is the DMA buffer - an 8 Kbyte buffer. The buffer is used for all transactions regardless of the direction.

The DMA controllers have been optimized to transfer data over the PCI/X bus in multiple cache-line bursts. All interactions with the VMEbus are handled by the VME Master. The controllers transfer data using 32-bit or 64-bit burst transfers on the PCI/X bus and 16-bit, 32-bit, or 64-bit transfers on the VMEbus.

4.3 DMA Buffers

Each DMA controller has an 8 Kbyte buffer that is used to hold data transferred between the source and destination bus. For example, if the transfer is from the PCI/X bus to the VMEbus, the DMA controller requests data from the PCI/X Master and then sends it to the VME Master.

The data moves from the PCI/X bus into the PCI/X Master's read buffer data queue and then through the Linkage Module to the buffer in the DMA controller. The data then moves from the DMA buffer through the Linkage Module to the VME Master's write buffer data queue. The data is then transferred to the VMEbus.

4.4 Operating Modes

There are two operating modes for the DMA Controller: Direct mode and Linked-list mode. In Direct mode, the DMA control registers are programmed by the processor. Once the command has completed, the status of the completed command is given within the DMA status registers and an optional interrupt is asserted on the INT_x signal lines (see [Section 8.4.2 on page 161](#)).



When the Tsi148's DMA interface signals a DONE interrupt, data could still be queued in either the Tsi148's VME Master interface buffer, or the PCI/X Master interface buffer, depending on the direction of the DMA transfer. In order to ensure all DMA data has been flushed from within the Tsi148, a local processor can initiate a read from VME memory (that is, a Tsi148 register in CR/CSR space, etc.)

In Linked-list mode, the DMA controller executes a list of commands which are stored in system memory. The DMA fetches these commands from the PCI/X bus. Once all the commands have been fetched and executed, the status of the completed commands is given within the DMA status registers and, optionally, an interrupt is asserted on the INT_x signal lines.

[Figure 18](#) shows the DMA controller's direct mode.

Figure 18: Direct Mode

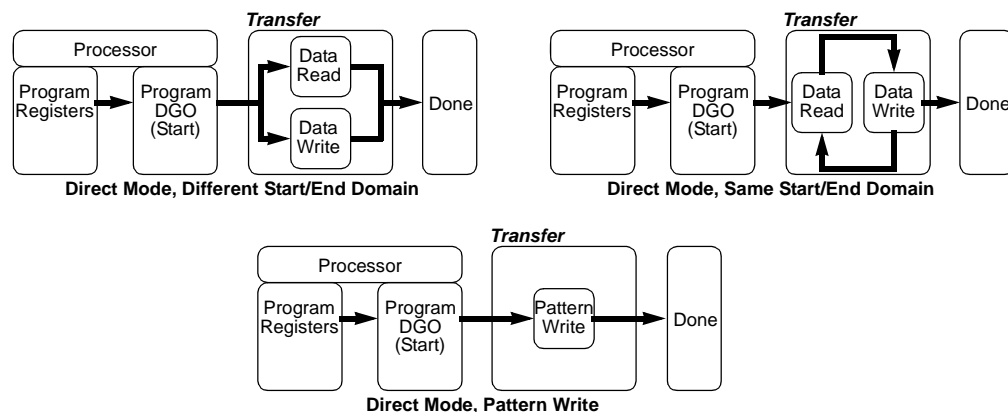

[Figure 19](#) shows the linked-list mode of the DMA controller.

Figure 19: Linked-list Mode

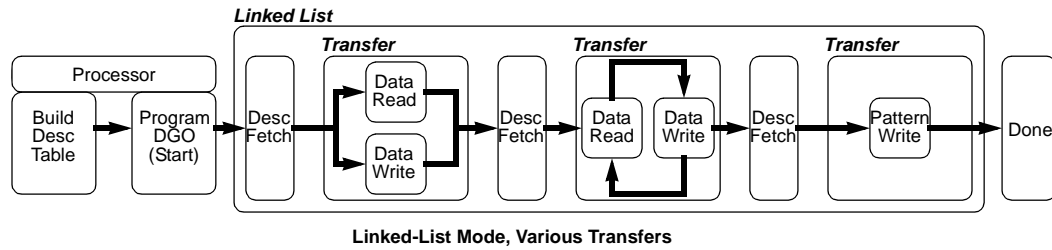

4.4.1 Linked-List Descriptors

The PCI/X Master is responsible for fetching descriptors from local memory when using Linked-List Mode. Each descriptor consumes 40 bytes and must be aligned on 64-bit boundaries. This structure helps minimize the PCI/X bus bandwidth used when fetching descriptors.

Table 4 shows the format of a descriptor.

Table 4: DMA Controller Linked-List Descriptors

Offset	Bits					
	63		32	31		0
0x00	DSAU			DSAL		
0x08	DDAU			DDAL		
0x10	DSAT			DDAT		
0x18	DNLAU			DNLAL		
0x20	DCNT			DDBS		

Each field within the descriptor corresponds to a DMA control register. When a descriptor is loaded by the DMA controller, each field is placed into its corresponding DMA control register (see Section 10.4.76 on page 331).

The descriptors are linked together by the DNLA register (that is, the DNLA field within a descriptor). This field contains the address within PCI address space where the next descriptor may be found. The Last Link-descriptor Address field (LLA) within the DNLA indicates that this is the last descriptor.

Descriptors are not prefetched by the PCI/X Master. A linked-list mode command is started by the PCI/X Master reading one descriptor. The DMA controller then performs the transfer associated with that descriptor. If there are more descriptors to be executed, the fetching of the next descriptor does not occur until the current transfer has completed.

4.5 Direction of Data Movement

There are four possible directions for data movement within a transfer.

- **PCI/X-to-VME:** Data is read from PCI/X and written to the VMEbus. The PCI/X Master fills the DMA buffer at the same time the VME Master empties the DMA buffer.
- **VME-to-PCI/X:** Data is read from the VMEbus and written to the PCI/X bus. The VME Master fills the DMA buffer at the same time that the PCI/X Master empties the DMA buffer.
- **PCI/X-to-PCI/X:** Data is read from the PCI/X bus and written back sometime later to the PCI/X bus. The PCI/X Master fills the DMA buffer to a certain point, after which the PCI/X Master empties the DMA buffer.
- **VME-to-VME:** Data is read from the VMEbus and written back sometime later to the VMEbus. The VME Master fills the DMA buffer to a certain point, after which the VMEbus Master empties the DMA buffer.
- **Data Pattern to VME:** A data pattern is written into the DMA buffer and then written to the VMEbus. The pattern generator fills the DMA buffer at the same time that the VME Master empties the DMA buffer. The data pattern can either be a fixed pattern or an incrementing pattern. For data pattern programming information refer to [Section 10.4.89 on page 353](#).
- **Data Pattern to PCI/X:** A data pattern is written into the DMA buffer and then written to the PCI/X bus. The pattern generator fills the DMA buffer at the same time that the PCI/X Master empties the DMA buffer. The data pattern can either be a fixed pattern or an incrementing pattern. For data pattern programming information refer to [Section 10.4.89 on page 353](#).

4.5.1 PCI/X-to-VME

The Tsi148 DMA controllers support PCI/X-to-VME DMA transactions.

Example DMA PCI/X-to-VME Transaction

In this example, there is a DMA transaction between the PCI/X bus and VMEbus. The following list, and [Figure 20](#) and [Figure 21](#), show the steps taken in the DMA transaction.

1. Program the registers in the LCSR group.
 - The DMA registers set-up the following information:
 - Source and destination buses, and starting address
 - Mode of operation

- Attributes
- Bus width
- Transfer throttling
- DMA transfer count



Transfer counts can be between 1byte and 4 Gbytes.

Figure 20: DMA Transaction: PCI/X-to-VME Request

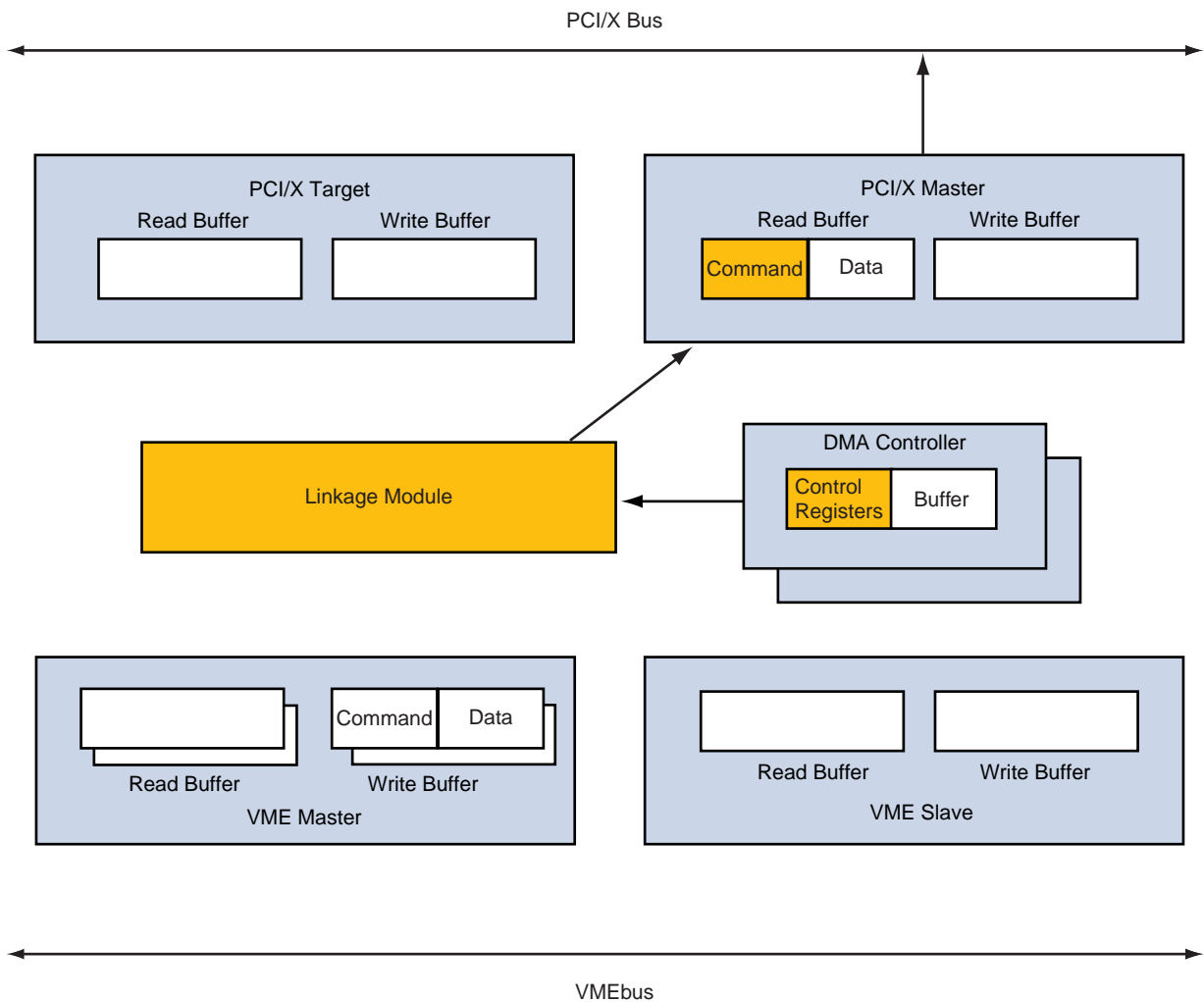

2. Once these registers have been programmed, writing to the DGO bit in the DMA control register to initiates the DMA transfer.
3. The DMA controller issues a read request to the Linkage Module.

4. After arbitration the Linkage Module passes the command, address information and transfer size to the PCI/X Master read buffer command queue.
5. The PCI/X Master issues a read request to the PCI/X target.

Figure 21: DMA Transaction: PCI/X-to-VME Completion

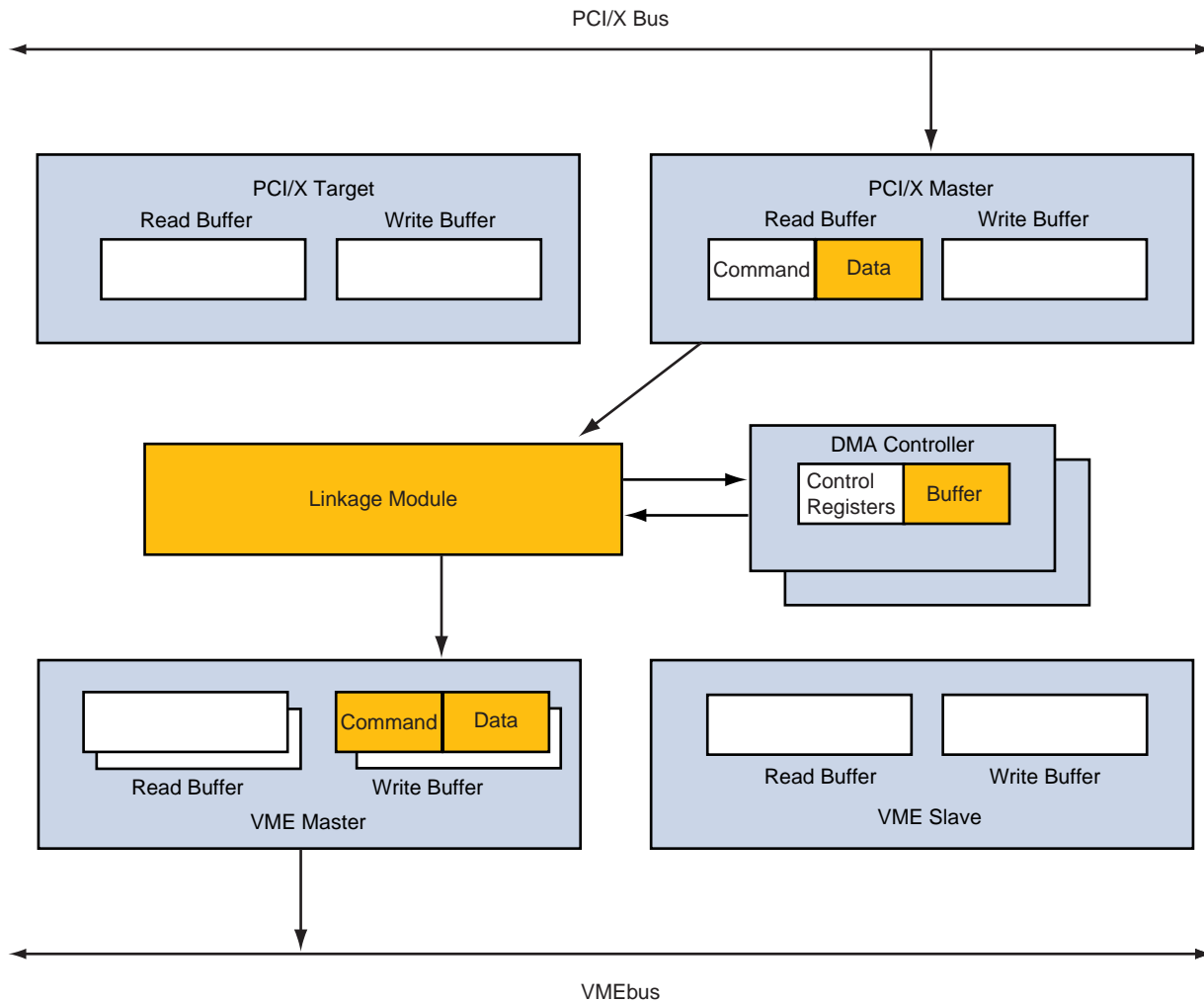

6. Once the read request is satisfied or the PCI/X Master's read buffer data queue becomes full, the PCI/X Master makes a request to the Linkage Module.
 - The Block Size is programmed in the PBKS field in the DMA Control register when the PCI/X bus is the source bus (see [Section 10.4.76 on page 331](#)).
7. After arbitration, the read data is passed through the Linkage Module to the DMA controller's data buffer. The data buffer is used to hold data that is transferred between the source and destination bus.

8. The DMA controller issues a write request to the Linkage Module.
9. After arbitration, the Linkage Module passes the command information, address information, and write data to a VME Master's write buffer.
10. The VME Master completes the write transaction to the VMEbus slave. For large transfers the PCI/X Master attempts to fill the DMA buffer while the VME Master transfers data from the DMA buffer.

4.5.2 VME-to-PCI/X

The Tsi148 DMA controllers support VME-to-PCI/X DMA transactions.

4.5.2.1 Example DMA VME-to-PCI/X Transaction

In this example, there is a DMA transaction between the VMEbus and PCI/X bus. The following list, and [Figure 22](#) and [Figure 23](#), show the steps taken in the DMA transaction.

1. Program the registers in the LCSR group.
 - The DMA registers set-up the following information:
 - Source and destination buses, and starting address
 - Mode of operation
 - Attributes
 - Bus width
 - Transfer throttling
 - DMA transfer count



Transfer counts can be between 1byte and 4 Gbytes.

Figure 22: DMA Transaction: VME-to-PCI/X Request

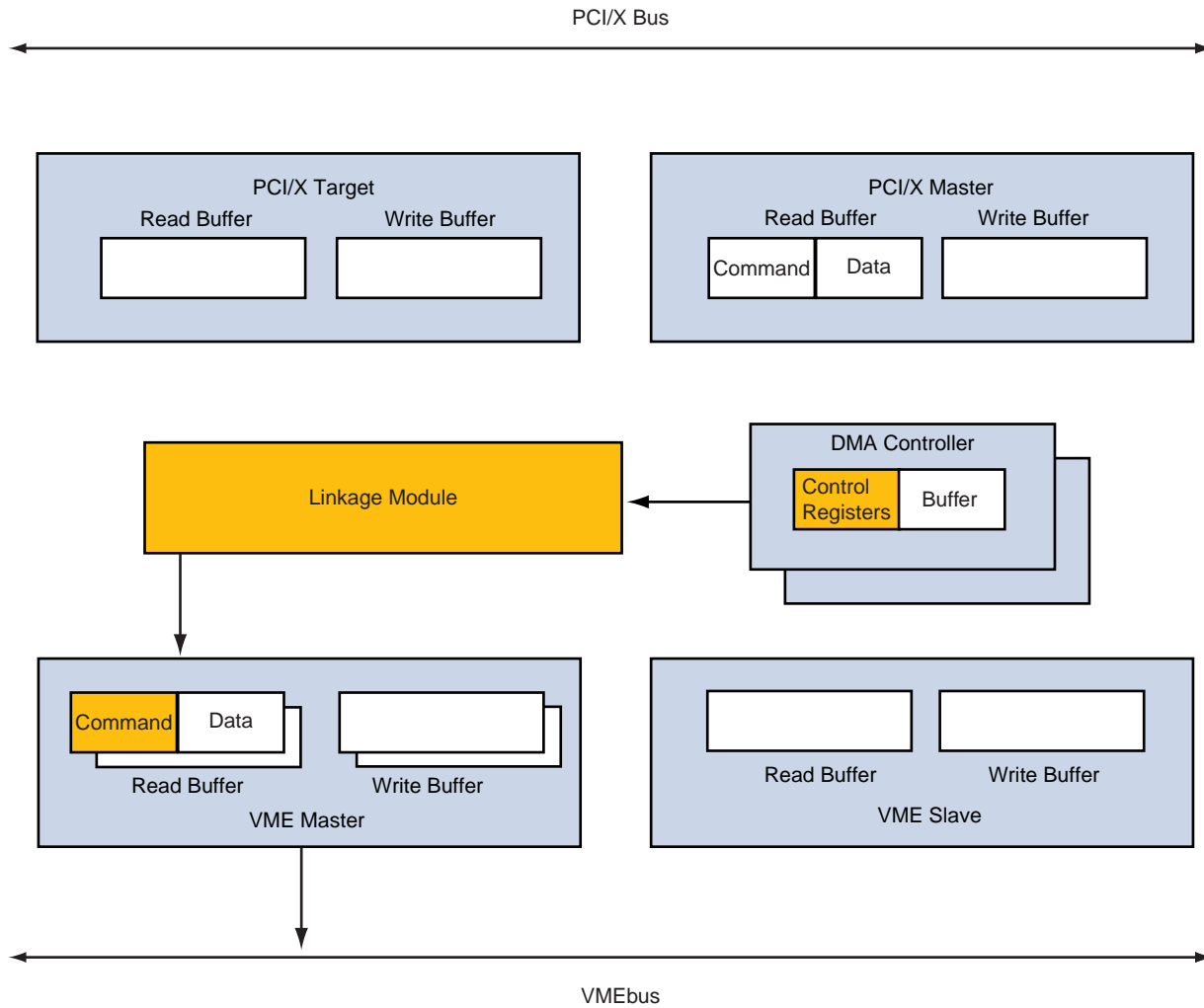

2. Once these registers have been programmed, writing the DGO bit in the DMA control register initiates the DMA transfer.
3. The DMA controller issues a read request to the Linkage Module.
4. After arbitration, the Linkage Module passes the command information and address information to a VME Master read buffer.
5. The VME Master issues a read request to the VMEbus slave.

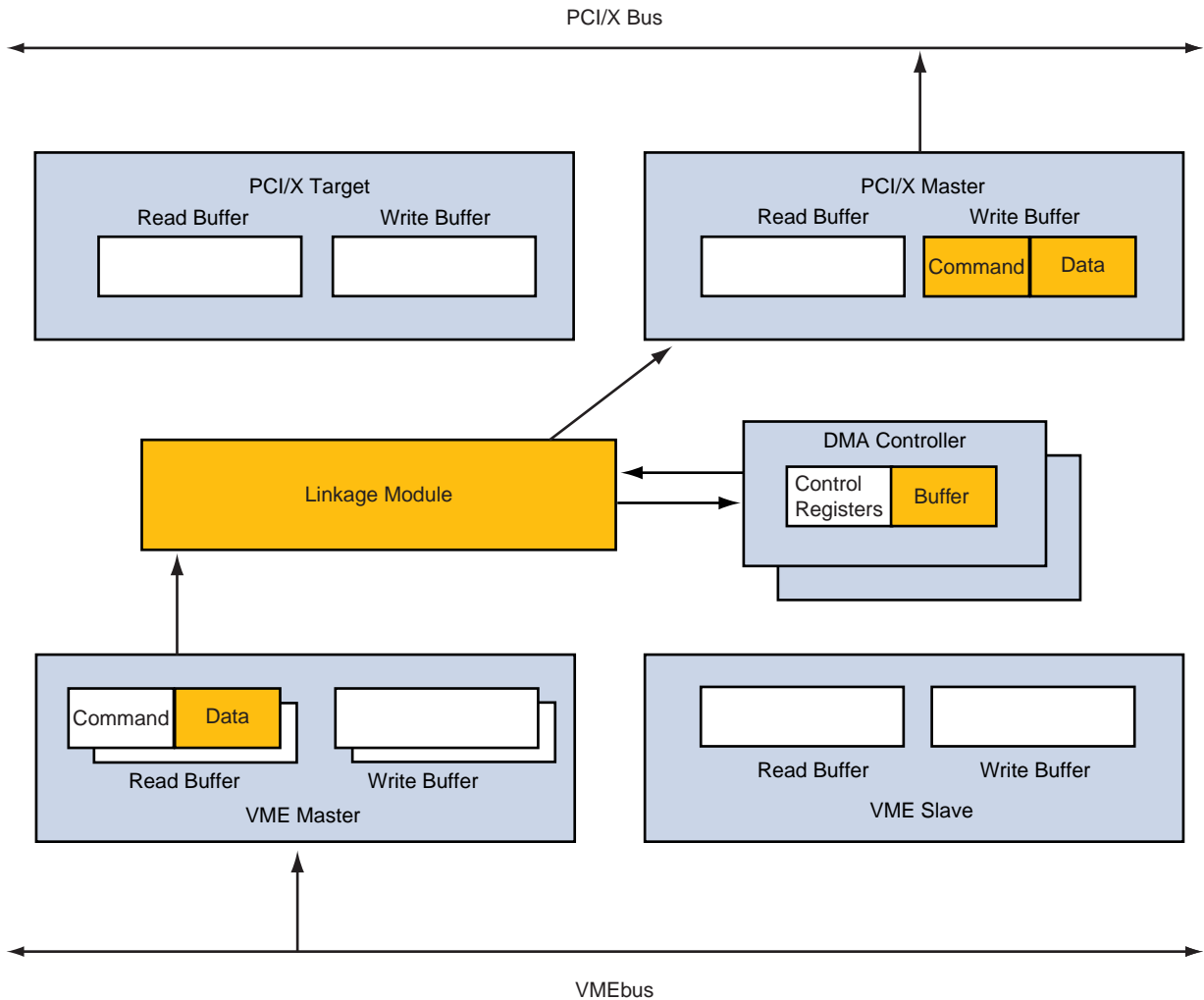
Figure 23: DMA Transaction: VME-to-PCI/X Completion

6. Once the read request is satisfied, or the programmed VMEbus block size value is satisfied, the VME Master makes a request to the Linkage Module.
 - The Block Size is programmed in the VBKS field in the DMA Control Register when VME is the source bus (see [Section 10.4.76 on page 331](#)).
7. After arbitration, the read data is passed through the Linkage Module to the DMA controller's data buffer. The data buffer is used to hold data that is transferred between the source and destination bus.
8. The DMA controller then issues a write request to the Linkage Module.

9. After arbitration, the Linkage Module passes command information, address information, and the write data to the PCI/X Master write buffer's command and data queues.
10. The PCI/X Master initiates the write transaction to the PCI/X target. For large transfers the VME Master fills the DMA buffer while the PCI-X Master attempts to transfer data from the DMA buffer.

4.5.3 PCI/X-to-PCI/X

The Tsi148 DMA controllers support PCI/X-to-PCI/X DMA transactions.

4.5.3.1 Example DMA PCI/X-to-PCI/X Transaction

In this example, there is a DMA transaction between the PCI/X bus and PCI/X bus. The following list, and [Figure 24](#) and [Figure 25](#), show the steps taken in the DMA transaction.

1. Program the registers in the LCSR group.
 - The DMA registers set-up the following information:
 - Source and destination buses, and starting address
 - Mode of operation
 - Attributes
 - Bus width
 - Transfer throttling
 - DMA transfer count

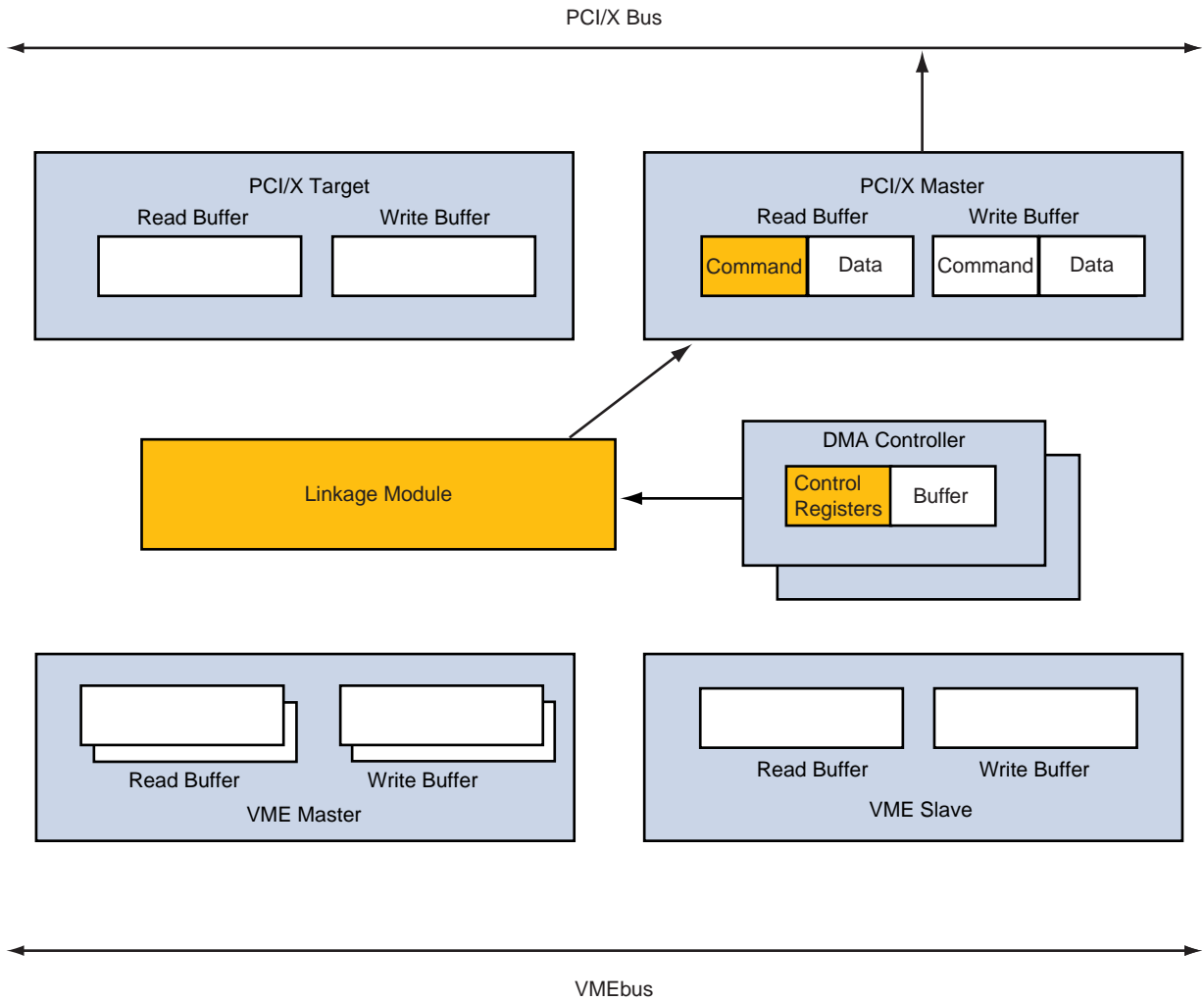

Transfer counts can be between 1 byte and 4 Gbytes.

Figure 24: DMA Transaction: PCI/X-to-PCI/X Request

2. Once these registers have been programmed writing the DGO bit in the DMA control register initiates the DMA transfer.
3. The DMA controller issues a read request to the Linkage Module.
4. After arbitration, the Linkage Module passes the command, address information, and transfer size are passed to the PCI/X Master read buffer command queue.
5. The PCI/X Master issues a read request to the PCI/X target.

Figure 25: DMA Transaction: PCI/X-to-PCI/X Completion

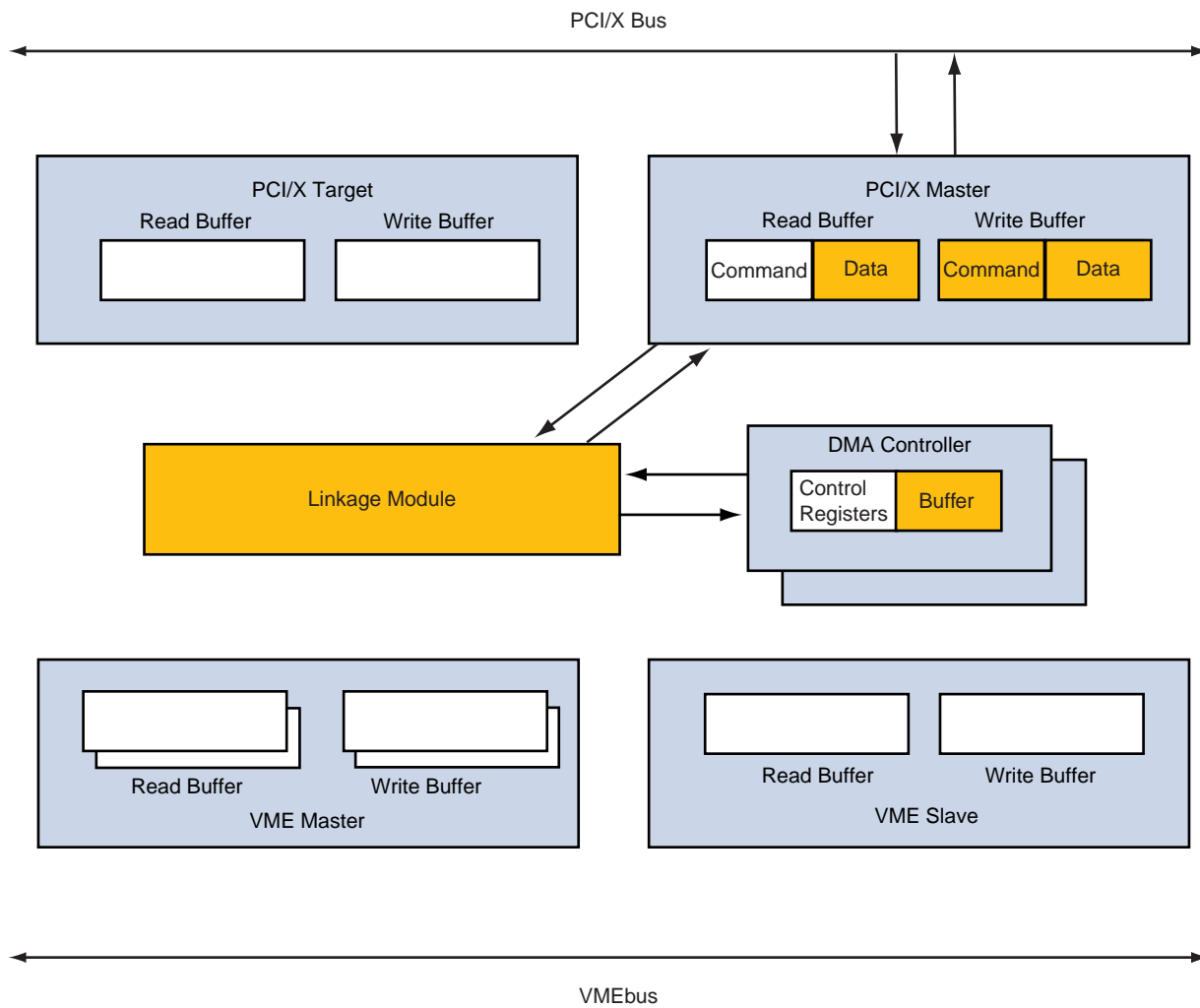

6. The PCI/X target satisfies the read request and the data is stored in the PCI/X Master's read buffer data queue.
7. Once the read request is satisfied, or the PCI/X Master's read buffer data queue becomes full, the PCI/X Master makes a request to the Linkage Module.
8. After arbitration the read data is passed through the Linkage to the DMA Controllers data buffer. The data buffer is used to hold data that is transferred between the source and destination bus. In this example between the PCI/X bus and PCI/X bus.
9. The DMA controller then issues a write request to the Linkage Module.
10. Upon arbitration the command, address information as well as the write data is passed to the PCI/X Master write buffer command and data queues.

11. The PCI/X Master initiates the write transaction to the PCI/X peripheral. The PCI/X Master fills the DMA buffer to a certain point, after which the PCI/X Master empties the DMA buffer.

4.5.4 VME-to-VME

The Tsi148 DMA controllers support VME-to-VME DMA transactions.

4.5.4.1 Example DMA VME-to-VME Transaction

In this example, there is a DMA transaction between the VMEbus and VMEbus. The following list, and [Figure 26](#) and [Figure 27](#), show the steps taken in the DMA transaction.

1. Program the registers in the LCSR group.
 - The DMA registers set-up the following information:
 - Source and destination buses
 - Mode of operation
 - Attributes
 - Bus width
 - Transfer throttling
 - DMA transfer count



Transfer counts can be between 1 byte and 4 Gbytes.

Figure 26: DMA Transaction: VME-to-VME Request

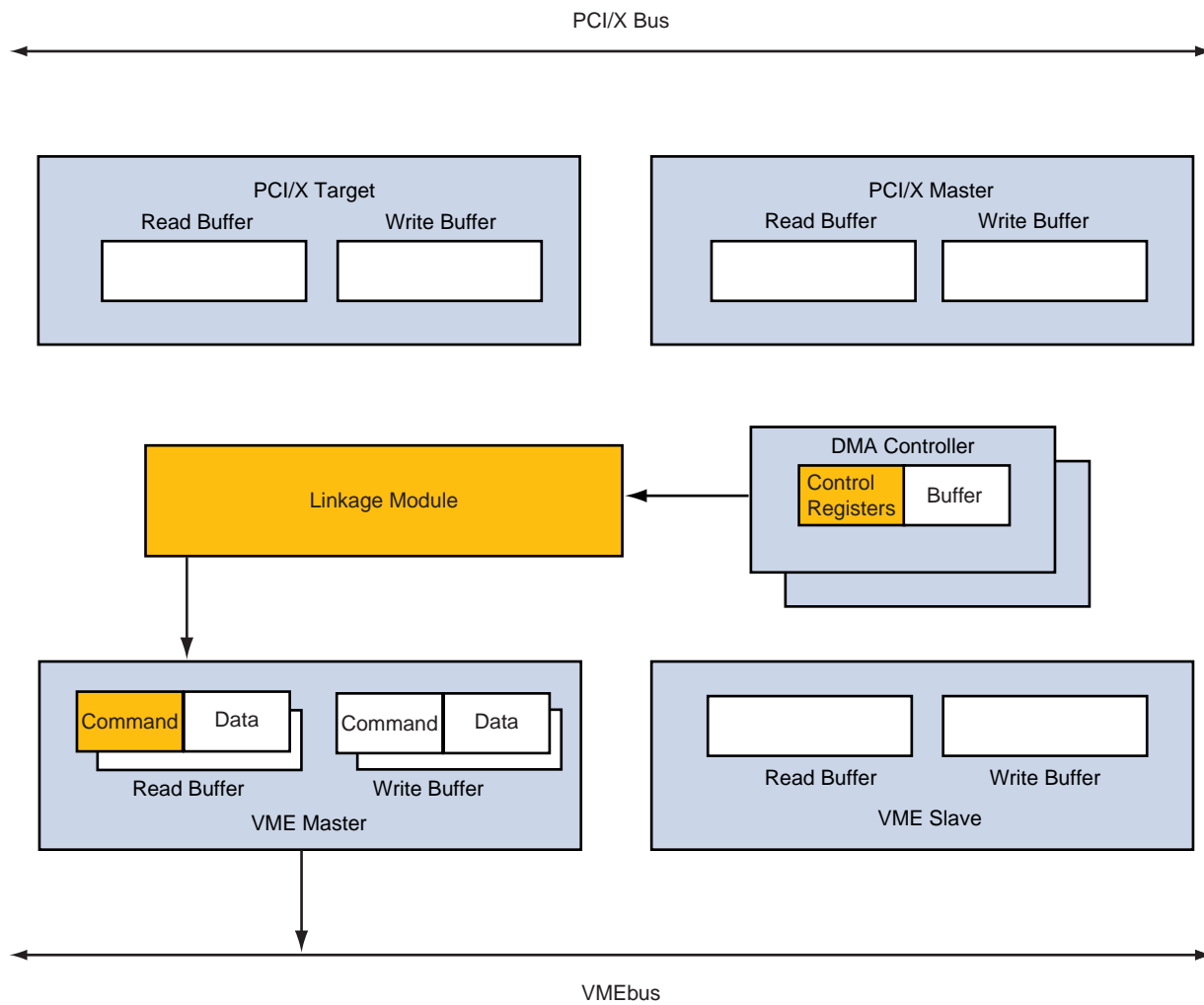

2. Once these registers have been programmed writing the DGO bit in the DMA control register initiates the DMA transfer.
3. The DMA controller issues a read request to the Linkage Module.
4. After arbitration, the Linkage Module passes command information, address information, and transfer size to one of the VME Master's two read buffer command queues.
5. The VME Master issues a read request to the VMEbus slave.

Figure 27: DMA Transaction: VME-to-VME Completion

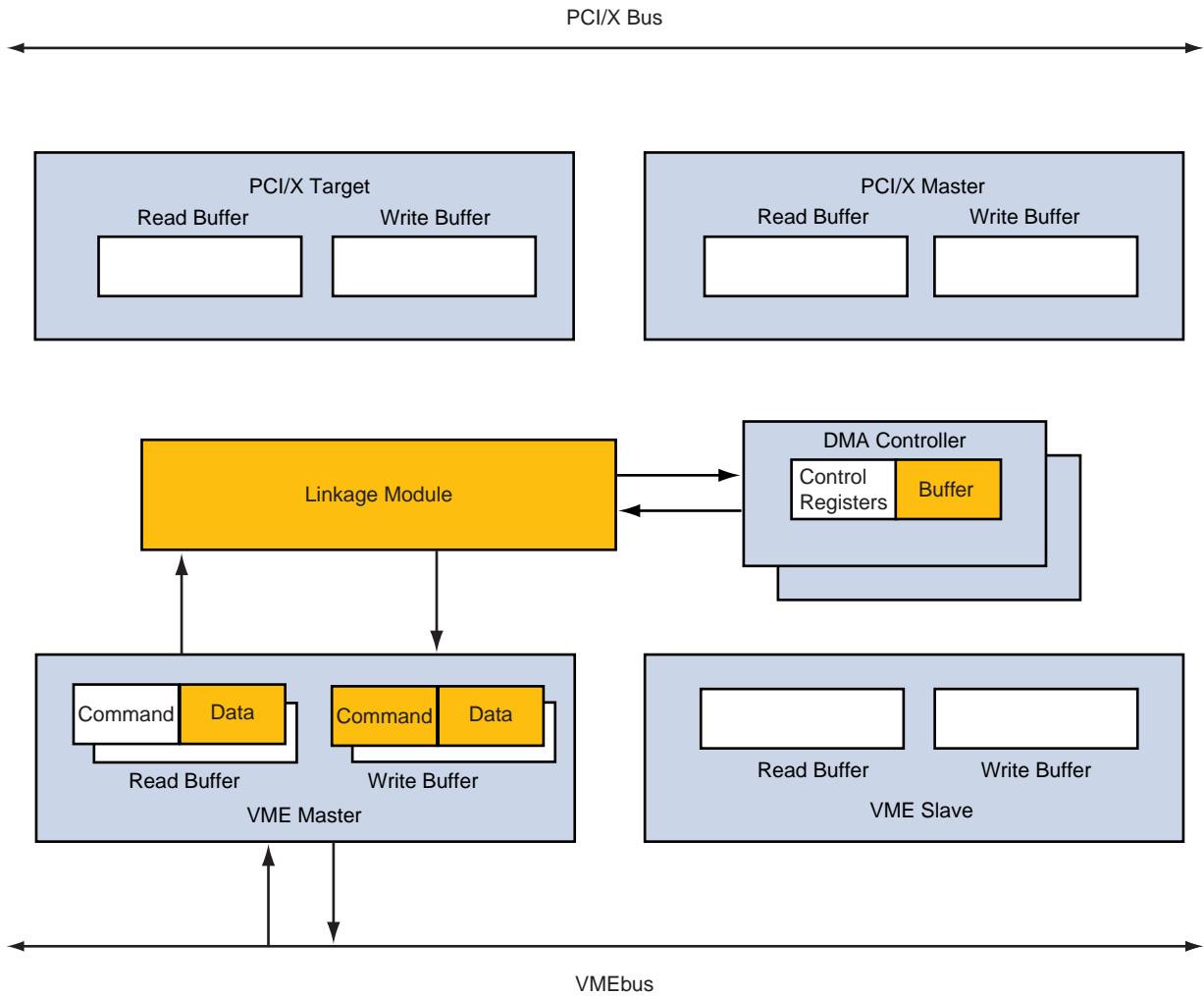

6. Once the read request is satisfied, or the programmed VMEbus block size value is satisfied, the VME Master makes a request to the Linkage Module.
 - The Block Size is programmed in the VBKS field in the DMA Control Register when VME is the source bus (see [Section 10.4.76 on page 331](#)).
7. After arbitration, the Linkage Module passes the read data to the DMA controller's data buffer. The data buffer is used to hold data that is transferred between the source and destination bus.
8. The DMA controller issues a write request to the Linkage Module.
9. After arbitration, the command, information, address information, and write data is passed to a VME Master write buffer command and data queue.

- The VME Master initiates the write transaction to the VMEbus slave. The VME Master fills the DMA buffer to a certain point, after which the VME Master empties the DMA buffer.

4.5.5 Data Patterns

The Tsi148's DMA Controller can write data patterns to either VME or PCI/X space. The data patterns can be any size transfer, and there are no restrictions on the starting address.

The starting data pattern is supplied by software. Software can also specify whether the pattern should be static or incrementing. The DMA Controller can be programmed to work in terms of 8-bit patterns (see Figure 28) or 32-bit patterns (see Figure 29).

Figure 28: 8-bit Pattern Writes

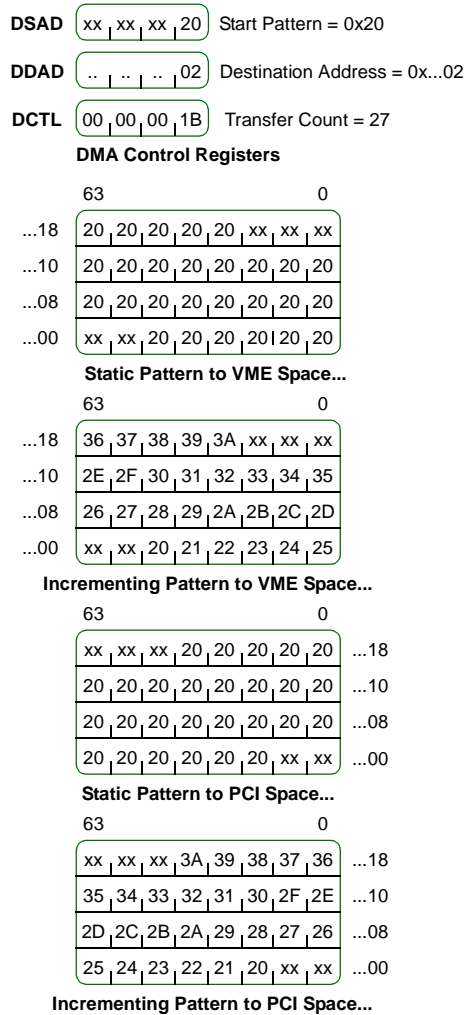
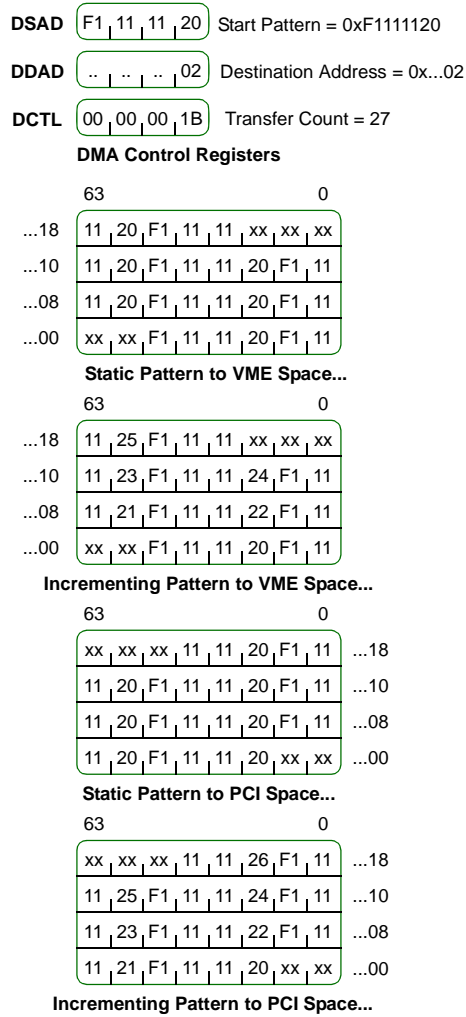

Figure 29: 32-bit Pattern Writes



4.5.5.1 Data Patterns and Endianness

When writing 32-bit patterns to PCI/X space, the pattern is not Endian byte swapped. Also, when writing 332-bit patterns, a transfer count that is not an even multiple of four is rounded off of the last data pattern written to either VME or PCI/X space. The rounding off occurs on the pattern according to the address space being written to. For example, a pattern written to PCI/X space is rounded off starting from the left side (Most Significant Bit) of the pattern, while a pattern written to VME space is rounded off starting from the right (or Least Significant Bit) side of the pattern.

4.5.6 DMA Transaction Termination

Tsi148 DMA activity can be terminated through either a transfer completion, commanded stop, commanded abort, or a detected error abort.

4.5.6.1 Transfer Completion

In most cases, a Direct mode transfer or a Linked-list mode transaction finishes without intervention or error. In Direct mode operation, the end of the transfer is considered completion. In Linked-List mode operation, the end of the last transfer of a command is considered completion. When the transaction is complete, the DMA controller returns a done status to the DMA Status (DSTA) register (see [Section 10.4.77 on page 336](#)) and, when enabled, interrupts the processor.

4.5.6.2 Commanded Stop

The commanded stop termination can be used during Linked-list transactions. Software is used to set the Commanded Stop bit (PAU) in the DMA Control register (see [Section 10.4.76 on page 331](#)). This bit can be set at any time during a DMA transaction.

When the DMA controller reaches a transfer boundary (that is, ready to fetch the next descriptor), it stops all DMA activity. If there are more Linked-list commands to be performed, the DMA controller returns a paused status to the DSTA register and, optionally, interrupts the processor. If the last command has completed, then the DMA controller returns a done status to the DSTA register (see [Section 10.4.77 on page 336](#)).

Once the transaction has been stopped, the linked list transaction can be started again at any time. The DMA controller starts the transaction where it left off. The first descriptor fetch occurs from the address that was placed within the DMA Next Link Address (DNLA) register during the previously completed transfer (see [Section 10.4.90 on page 357](#)).

4.5.6.3 Commanded Abort

The commanded abort termination can occur on either Direct mode or Linked-list mode. Software is used to set the Commanded Abort bit in the DMA Control (CTL) register (see [Section 10.4.76 on page 331](#)). This bit can be set at any time during a transaction.

When the Commanded Abort bit is set, the DMA controller aborts all DMA activity. This is considered a non-recoverable termination, and it takes affect immediately after the bit has been set. If the commanded abort took affect before all commands were completed, then the DMA controller returns an abort status to the DSTA register and, optionally, interrupts the processor. If all commands completed before the commanded abort took affect, then the controller returns a done status to the DMA Status (DSTA) register (see [Section 10.4.77 on page 336](#)).

4.5.6.4 Detected Error Abort

If any of following system errors are encountered, the DMA controller aborts all DMA activity:

- PCI/X Master received a master abort
- PCI/X Master received a target abort
- PCI/X Master exceeds the maximum retry count
- VME Master received a bus error
- VME Master received slave termination

This is considered a non-recoverable termination, and takes affect immediately after the condition has been detected. Once all DMA activity has ceased, the DMA controller returns the appropriate error status to the DSTA register and, if enabled, interrupts the processor.

4.5.7 DMA Interrupts

The DMA Controller sends an interrupt to the interrupt controller when it returns to the idle state. If the DMA interrupt in the interrupt controller is enabled, an INTx signal line is asserted to signal the interrupt.



The DSTA register can be read at any time to obtain the operating status of the controller.

4.5.8 Transfer Throttling

The Tsi148 has the ability to throttle DMA transfers. This features is for situations where the VMEbus or PCI/X bus bandwidth that is consumed by the DMA Controller could swamp the system with DMA activity. There are several methods available to control the bandwidth consumed by the DMA controller. The PCI/X bus latency timer and the VMEbus time-on timer can be used to control the VMEbus and PCI/X bus time allocated to the Tsi148. In addition the DMA controller has a programmable block size and back-off timer.

The block size can be set from 32 to 4096 bytes. The back-off value can be set from 0 to 64 us. The block size and back-off time are independently programmable for each bus. The DMA controller requests the selected block size and when that request is satisfied, it waits for the time set by the back-off timer before requesting a new block.



Larger DMA block sizes are more efficient but increase latency. Smaller DMA block sizes reduce latency but are less efficient.

5. Resets, Clocks, and Power-up Options

Reset options include how a device or components of a device are reset, and how the device responds to a reset event. Clock characteristics include how a device's operating frequency is set, and if required, how it should be synchronized with other devices in a system. Power-up options include device-specific capabilities that are configured upon the completion of a power-up reset sequence. These include functions such as bus mode (PCI versus PCI/X) and data width size (32-bit versus 64-bit).

This chapter discusses the following topics about Tsi148 Resets, Clocks, and Power-up Options:

- [“Overview of Resets, Clocks, and Power-up Options” on page 122](#)
- [“Resets” on page 122](#)
- [“Clocks” on page 127](#)
- [“Power-up Options” on page 128](#)

5.1 Overview of Resets, Clocks, and Power-up Options

This section describes the reset capabilities, clocking requirements, and power-up options for the Tsi148 device.

5.2 Resets

Tsi148 can be reset from both the VMEbus and the PCI/X bus. The device responds to both hardware and software reset events. **Figure 30** shows the logical representation of the Tsi148 reset structure.

Figure 30: Tsi148 Reset Structure

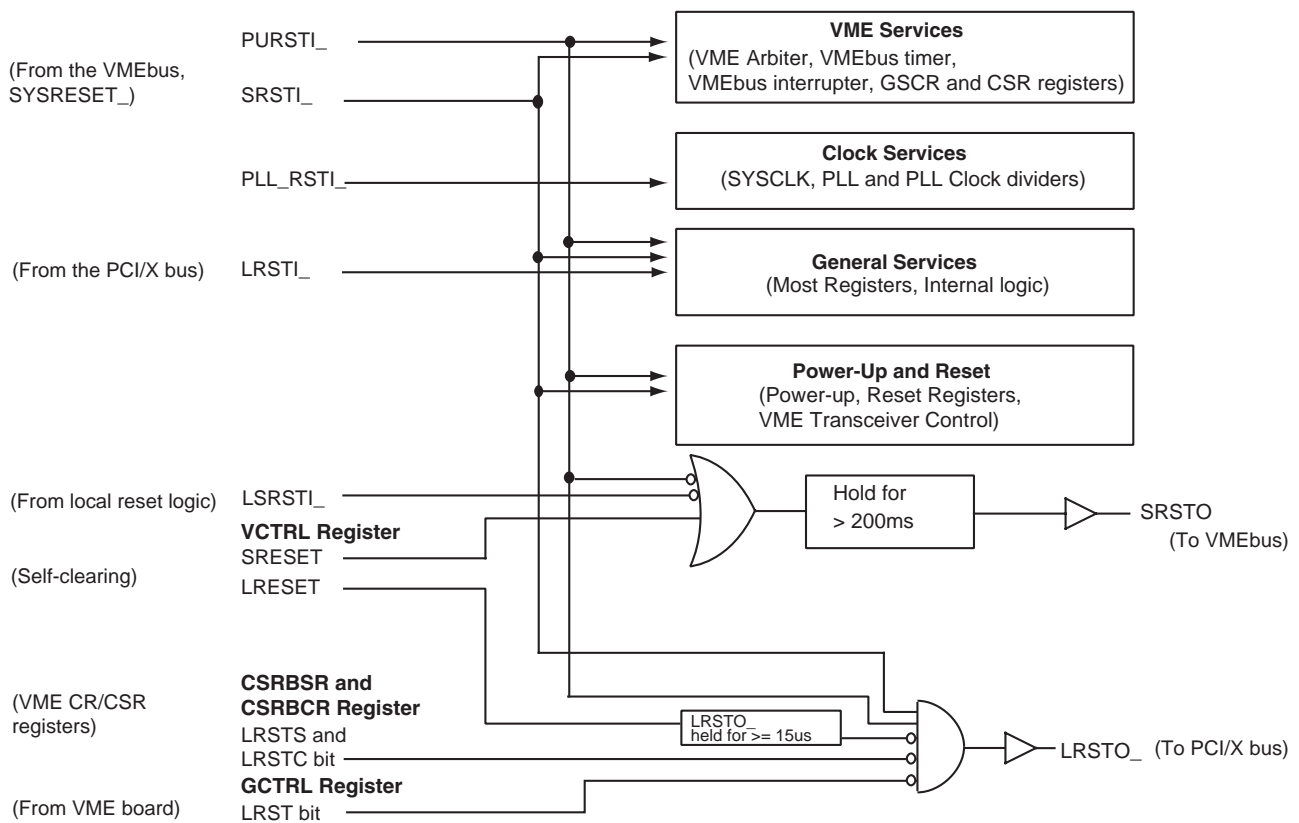

5.2.1 Reset Inputs and Outputs

Tsi148 has the following reset inputs and reset outputs:

- Reset Inputs
 - Power-up Reset (PURSTI_): This signal resets all of the Tsi148 logic. When it is asserted both the PCI/X and VMEbus can be reset through the Tsi148 reset outputs LRSTO_ and SRSTO.
 - VMEbus System Reset In (SRSTI_): This signal resets all of the Tsi148 logic which is sensitive to SYSRESET. Typically, the backplane SYSRESET_ is connected to this signal through a transceiver. When SRSTI_ is asserted the PCI/X bus can be reset through the Tsi148 reset output LRSTO_.
 - PLL Reset (PLL_RSTI_): This signal resets the Tsi148 PLL. The PLL_RSTI_ pin has to be asserted until the clock and power are stable.
 - JTAG Test Reset (TRST_): Provides asynchronous initialization of the TAP controller in the Tsi148. This signal must be tied to ground if JTAG is not used in the system. If JTAG is used in the system, the TRST_ input must be asserted low at the negation of the PURST_ input and then held high during boundary scan testing.
 - Local Bus (PCI/X) Reset In (LRSTI_): Assertion of this signal resets all Tsi148's internal logic except the logic required for VME services and clock service (see [Figure 30](#)). This signal should be connected to the board's local bus (PCI/X) reset.
 - Local System Reset (LSRSTI_): This signal is used to reset the VMEbus from the PCI/X bus. When this signal is asserted the Tsi148 output SRSTO is asserted. This signal allows on board logic to generate a VMEbus system reset.

- Reset Outputs

- VMEbus System Reset Out (SRSTO): This signal is used to reset the VMEbus. Typically, this signal is connected to the backplane SYSRESET_ signal through an inverting open collector buffer. When SRSTO is asserted, the VMEbus SYSRESET_ signal is asserted.

SRSTO can be asserted either through hardware or software events. The hardware reset events are detailed in [Figure 30](#). The signal can be asserted through software by setting the SRESET bit in the VMEbus Control (VCTRL) register (see [Section 10.4.34 on page 257](#)).



If the SRESET bit is set, the Tsi148 asserts SRSTO output even if it is not the system controller.

The SRESET bit is self-clearing if SRSTI is connected to SRSTO through a transceiver.



The SRSTO signal is asserted for a minimum of 200ms.

- Local Bus (PCI/X) Reset Out (LRSTO_): This signal resets local (PCI/X) resources. LRSTO_ can be combined with other board sources to generate a local (PCI/X) reset signal.

LRSTO_ can be asserted either through hardware or software events. The hardware reset events are detailed in [Figure 30](#). This signal can be asserted through software by the following methods:

- Setting the LRESET bit in the VCTRL register (see [Section 10.4.34 on page 257](#)). The LRESET bit is self clearing. When the LRESET bit is set the LRSTO_ signal remains asserted for a minimum of 15us. Because this bit only resets the board and not the entire system, setting this bit can have side effects. For example, if there are VMEbus transfers in progress, local resources required to complete the transfers are reset and unavailable. This may cause aborted VMEbus cycles, VMEbus time-outs, or a VMEbus lockup. To avoid these side effects, the following rules must be used when setting the LRESET bit:
 1. The LRESET bit must only be used in exceptional cases and not during normal system operation.
 2. The software must set VMEbus Stop (VS) bit and wait for the VMEbus Stop Acknowledge bit (VSA) to be set (see [Section 10.4.33 on page 253](#)). When the VS bit is set, Tsi148 acquires VMEbus ownership. This prevents any other VMEbus masters from acquiring the VMEbus. Setting the VS bit also prevents Tsi148 from starting any VMEbus cycles. This ensures that the VMEbus is in an idle state when the LRSTO_ signal is asserted. The LRESET bit can then be set.
- Setting the Local Reset (LRST) bit in the GCTRL register (see [Section 10.4.96 on page 362](#)). The LRSTO_ reset remains asserted as long as the LRST bit is set.
- Setting the Local Reset Set (LRSTS) bit in the CR/CSR Bit Set (CSRBSR) register (see [Section 10.4.102 on page 370](#)). When the bit is set the board is held in reset until a 1 is written to the LRSTC bit in the CSRBCR register.

5.2.2 Reset Timing

Figure 31 shows the power-up reset timing of Tsi148. The numbers in the figure correspond to the following values:

- 1 = PLL_RST_ hold time (0ns)
 - PLL_RST_ can be released once the PCLK and power are stable
- 2 = PURST_ hold time (150us)
 - PURSTI_ must be held after negation of PLL_RSTI_ to make sure the PLL is locked to the PCLK frequency
- 3 = Assertion of SRSTO (200ms)
 - Minimum assertion of SRSTO output (as required by the *American National Standard for VME64*)

Figure 31: Timing for Power-up Reset

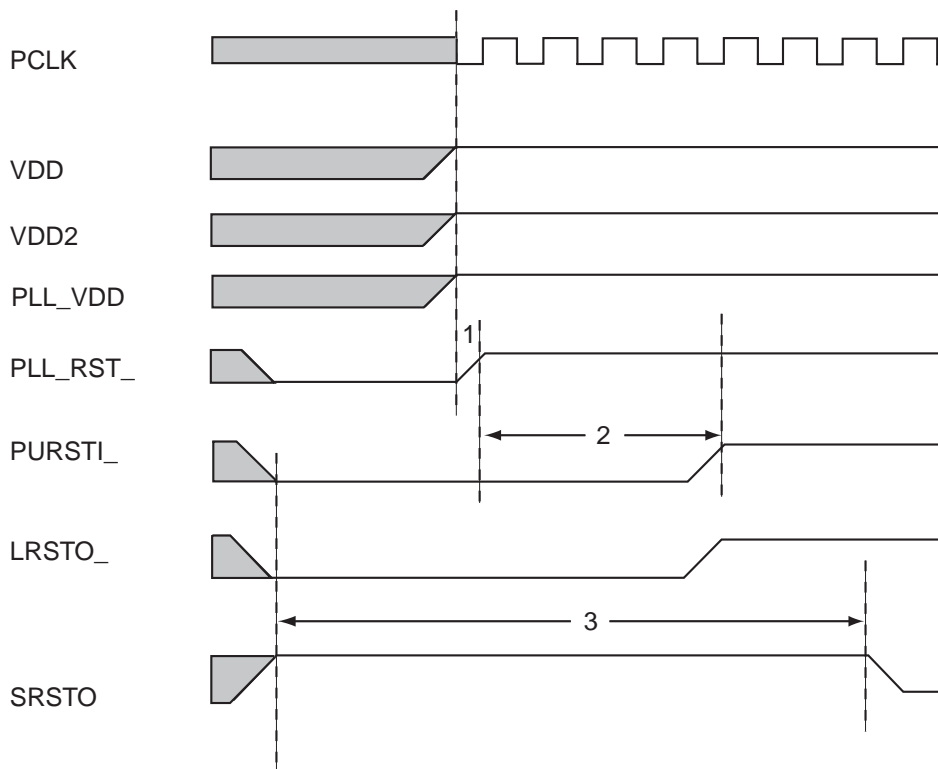

5.3 Clocks

Tsi148 clocks are derived from the PCI/X bus clock. The PCI/X bus clock frequency can be 33, 66, 100, or 133 MHz.



PCLK operation below 33 MHz is not recommended.

The PCI/X clock frequency and bus mode is configured on the rising edge of LRSTI_ (see [Table 5](#))

Table 5: PCI Bus Configuration

PCI Bus Signal						PCI Bus Mode	PCI Clock Frequency (MHz)	
FRAME__	IRDY__	DEVSEL__	STOP__	TRDY__	M66EN		Min	Max
1	1	1	1	1	0	PCI	33.3	33.3
1	1	1	1	1	1	PCI	50	66.6
1	1	1	1	0	X	PCI-X	50	66.6
1	1	1	0	1	X	PCI-X	66.6	100
1	1	1	0	0	X	PCI-X	100	133.3

The PCI bus configuration signals are latched on the negation of LRSTI_. The Tsi148 expects the PCI bus configuration signals to be valid from the time the PLL reset input is negated (PLL_RSTI_) and remain valid until the LRSTI_ signal is negated. This allows the internal PLL to lock to the PCI/X bus clock.

The configuration signals are only latched on the first rising edge of LRSTI_. If LRSTI_ is asserted at a later time, the configuration signals are not latched again. However, if both PURSTI_ and LRSTI_ are reasserted, then the configuration signal latches are opened and the configuration signals are latched on the rising edge of LRSTI_.

The configuration signals are only latched once to make sure the PLL clock remains stable through a PCI/X bus reset. This stability enables a subset of the VMEbus logic to function while the PCI/X bus is in reset, including: the VMEbus SYSCLK, VMEbus arbiter, VMEbus daisy chain signals, VMEbus General Control and Status register access, and VMEbus Control and Control and Status register accesses.

The PCI/X bus clock input provides the reference clock for the internal PLL. The PLL is used to derive the 16 MHz VMEbus SYSCLK.

If the PCI/X clock input is below the maximum frequency defined for a specific configuration, the PLL frequency is scaled accordingly. When the PLL frequency is scaled down the VMEbus timing parameters are not violated, but the VMEbus performance and timer accuracy is affected. When this situation occurs the VMEbus SYSCLK output should not be used.

5.4 Power-up Options

Tsi148 samples various VMEbus and PCI/X bus signals during reset to enable or disable certain functions.

5.4.1 PCI/X Power-up Options

The PCI/X Interface has power-up options that control how the interface is configured for use in a system.

5.4.1.1 Bus Width

The PCI/X Interface supports 32-bit or 64-bit PCI/X bus widths. The PCI/X bus width is configured during a PCI/X bus reset. If REQ64_ is high during the rising edge of LRSTI_, then the chip is configured for 32-bit PCI/X. If REQ64_ is low during the rising edge of LRSTI_, then the chip is configured for 64-bit PCI/X. When the chip is used on a 32-bit PCI/X bus, REQ64_ should be pulled high with a weak pull-up resistor.

When the Tsi148 is used on a 32-bit PCI/X bus, it drives CBE[7:4]_, AD[63:32], and PAR64 at all times. These signals may be left unconnected when the chip is used on a 32-bit PCI/X bus. When the chip is used on a 64-bit PCI/X bus, it must not be configured for 32-bit operation. Other PCI/X devices may drive their 64-bit extension signals and this could cause excessive currents in the output drivers.



When in 32-bit PCI/X mode, the ACK64 signal must be pulled up with an external resistor.

Table 6 on page 129 shows Tsi148's PCI/X bus width configurations.

Table 6: PCI/X Bus Configuration

Function	Register	Reset	Sample Signal(s)	Sample State	Description
PCI/X Bus Data Width	PCI/X Configuration Status Register	LRSTI_	REQ64_	0	64-bit PCI/X bus
				1	32-bit PCI/X bus
PCI/X Mode		LRSTI_	M66EN, FRAME_, IRDY_, TRDY_, STOP_, DEVSEL_		Refer to Table 5 on page 127 .

5.4.1.2 Frequency

The mode and frequency of the PCI/X bus is determined the first time LRSTI_ is negated. The M66EN, FRAME_, IRDY_, TRDY_, STOP_ and DEVSEL_ signals are sampled on the rising edge of LRSTI_ and the PCI/X bus is configured (as defined in the *PCI-X Addendum to PCI Local Bus Specification (Revision 1.0b)*). For more information, refer to [Section 5.3 on page 127](#).

5.4.2 VMEbus Power-up Options

The Tsi148 VMEbus Interface supports a number of power-up options. Power-up options are latched during the assertion of PURSTI_. During power-up reset Tsi148 negates the External Transceiver Enable (DBOE_) signal, which puts the VD[31:0], VA[31:1], LWORD transceivers into a high impedance state. External pull-ups or pull-downs placed between Tsi148 and the external transceivers bring these power-up option signals to their proper state while DBOE_ is negated.

Table 7 shows the data signal and the functionality it enables through power-up configuration.

Table 7: VMEbus Power-up Options

Description	Power-up Option	VMEbus Data Signal	Control Register	Detailed Information
SFAILLEN Control Bit Reset Value	SFAILLEN_RV	VD[0]	Control and Status Register • SFAILLEN bit	"System Fail Enable (SFAILLEN) Configuration" on page 134
SFAILAI Control Bit Auto Clear	SFAILAI_AC	VD[1]	VMEbus Control Register • SFAILAI bit	"Auto Slot ID Operation" on page 132
Auto Slot ID Enable	ASIDEN	VD[2]	None - power-up option only	Table 8 and "Auto Slot ID Operation" on page 132
Geographical Slot ID Enable	GSIDEN	VD[3]	None - power-up option only	Table 8 and "Geographic Slot ID Enable" on page 133



Tundra recommends using 3.3kohm pull-up or pull-down resistors to set the desired level on the VME power-up options on the VD[3:0] pins. This resistor value has been determined to work correctly with the bus hold circuitry on the TI SN74VMEH22501/22501A 3A port pins.

5.4.2.1 ASIDEN and GSIDEN Power-up Options Assigning the CR/CSR Base Address

The data signals and the functionality they enable through power-up configuration are described individually, however the functions are not independent. The ASIDEN and GSIDEN functions define the method for assigning the CR/CSR base address. The interaction of these two functions is shown in [Table 8](#).

Table 8: ASIDEN and GSIDEN Definition

ASIDEN	GSIDEN	Description
0	0	CR/CSR Disabled
0	1	Geographical Address
1	0	Auto Slot ID
1	1	Geographical Address defaults to Auto Slot ID if GA[4:0] pins are all high

[Table 9](#) defines all combinations of the four VMEbus data bits.

Table 9: CR/CSR Base Address Configuration

VD[3:0]	GA (All High)	Description
00X0	X	CR/CSR disabled CRAT register, EN cleared by S reset VCTRL register, SFAILAI cleared by S reset GCTRL register, SFAILEN cleared by S reset
00X1	X	CR/CSR disabled CRAT.EN cleared by S reset VCTRL.SFAILAI cleared by S reset GCTRL.SFAILEN set by S reset
0100	X	Auto Slot ID CRAT register, EN cleared by S reset VCTRL register, SFAILAI set by S reset GCTRL register, SFAILEN cleared by S reset
01X1	X	Illegal Configuration
0110	X	Auto Slot ID CRAT register, EN cleared by S reset VCTRL register, SFAILAI set by S reset, cleared 1 ms after S reset GCTRL register, SFAILEN cleared by S reset

Table 9: CR/CSR Base Address Configuration

VD[3:0]	GA (All High)	Description
10X0	X	Geographical Addressing CRAT register, EN set by S reset VCTRL register, SFAILAI cleared by S reset GCTRL register, SFAILEN cleared by S reset
10X1	X	Geographical Addressing CRAT register, EN set by S reset VCTRL register, SFAILAI cleared by S reset GCTRL register, SFAILEN set by S reset
11X0	0	Geographical Addressing CRAT register, EN set by S reset VCTRL register, SFAILAI cleared by S reset GCTRL register, SFAILEN cleared by S reset
11X1	X	Illegal Configuration
1100	1	Default to Auto Slot ID CRAT register, EN cleared by S reset VCTRL register, SFAILAI set by S reset GCTRL register, SFAILEN cleared by S reset
1110	1	Default to Auto Slot ID CRAT register, EN cleared by S reset VCTRL register, SFAILAI set by S reset, cleared 1 ms after S reset GCTRL register, SFAILEN cleared by S reset

5.4.2.2 Auto Slot ID Operation

Tsi148 has Auto Slot ID functionality which is described in the *American National Standard for VME64*.

When the Auto Slot ID functionality is enabled in a system, after system reset each board in the system generates an interrupt on level IRQ2_. A level two interrupt handler module, called the *Monarch*, performs interrupt acknowledge cycles in response to each interrupt request. Before the Monarch can respond with its interrupt acknowledge cycle all boards in the system must have SYSFAIL_ negated. Once SYSFAIL_ is negated, the Monarch performs the interrupt service routine. Each VMEbus slave responds with an initial CR/CSR address space of zero. The Monarch then configures the CR/CSR base address of each board through its CR/CSR base address register.

Auto Slot ID Enable

The Auto Slot ID Enable (ASIDEN) feature is controlled through a power-up option. The ASIDEN feature allows the CR/CSR base address to be configured using the Auto Slot ID protocol. ASIDEN can be enabled through a power-up option (shown in [Table 7 on page 130](#)). The power-up option is sampled at the rising edge of the PURSTI_ signal.

System Failure Auto Slot ID (SFAILAI) Configuration

The System Failure Auto Slot ID (SFAILAI) bit is used when the Auto Slot ID protocol is enabled in the system to assign the CR/CSR base address. The initial value of the SFAILAI bit can be configured at power-up reset through the SFAILAI_AC power-up option or a value can be programmed by software in the SFAILAI bit in the VMEbus Control register (VCTRL) (see [Section 10.4.34 on page 257](#)).

When Auto Slot ID is used to assign the CR/CSR base address, the SFAILAI bit is set by the assertion of the SRSTI_ signal. The SFAILAI bit must be cleared in order for Tsi148's System Fail Output (SFAILO) signal to be negated. SFAILO is automatically negated if the SFAILAI_AC power-up option is selected, otherwise SFAILO is negated when software clears the SFAILAI bit in the VCTRL register.

This feature can be enabled through the SFAILAI_AC power-up option as shown in [Table 7 on page 130](#). The power-up option is sampled at the rising edge of the PURSTI_ signal.

5.4.2.3 Geographic Slot ID Enable

The Geographic Slot ID Enable function initializes the CR/CSR base address register using the VMEbus GA signals. The Geographic Slot ID Enable feature allows a board to come out of reset with the CR/CSR registers visible from the VMEbus and the base address of the CR/CSR is determined by the VMEbus GA signals.

The initial value of the CR/CSR Enable bit in the CR/CSR Attribute (CRAT) register and CBAR bits in the CR/CSR Base Address (CBAR) register can be configured at power-up reset using the Geographic Slot ID Enable function (see [Table 7 on page 130](#)). If the VD[3] signal is zero at the rising edge of the PURSTI_ signal, the CR/CSR enable bit and CBAR bits are cleared. If the VD[3] signal is one at the rising edge of the PURSTI_ signal, the CR/CSR enable bit is set and the CBAR bits 7 to 3 are set to the inverted value of the VMEbus geographic address signals. When the SRSTI_ signal is asserted, the CR/CSR EN bit and the CBAR bits are loaded with the power-up option reset values.

5.4.2.4 System Fail Enable (SFAILEN) Configuration

The Tsi148 System Failure Enable (SFAILEN) bit controls the assertion of the Tsi148 System Fail Output (SFAILO) signal. The only exception to this is when the Auto Slot ID method of assigning the CR/CSR base address is being implemented (as described in [Section 5.4.3 on page 135](#)). The initial value of the SFAILEN bit can be configured at power-up reset through the SFAILEN_RV power-up option. Additionally, a value can be programmed by software in the Control and Status register.

The Board Fail (BDFAIL_) signal, along with the SFAILEN bit, determine if the Tsi148 generates the SFAILO signal, in all cases except for the case where the Auto Slot ID method is being implemented. The Board Fail signal (BDFAIL_) can be generated either through software, by writing to the Board Fail bit (BRDFL) in the VMEbus Status register (see [Section 10.4.35 on page 261](#)), or by external logic on the board.

The SFAILO signal is controlled through the following registers:

- GCSR Control and Status register
 - The SFAILO signal can be enabled or disabled through the SFAILEN bit
- CR/CSR Bit Clear register
 - The SFAILO signal can be disabled through the SFAILC bit
- CR/CSR Bit Set register
 - The SFAILO signal can be enabled through the SFAILS bit

An access to any one of these three registers is transparent to the other registers. For example if the System Failure Enable is enabled through writing a 1 to the SFAILS bit in the CR/CSR register, the SFAILEN bit in the GCSR is also set.

This feature can be enabled through the SFAILEN_RV power-up option as shown in [Table 7 on page 130](#). The power-up option is sampled at the rising edge of the PURSTI_ signal.



The SFAILEN_RV power-up option must be cleared when using the Auto Slot ID (ASIDEN) power-up option to configure the CR/CSR base address register. Software must not set the SFAILEN bit until the Auto Slot ID process is complete.

5.4.3 System Controller (SCON)

Tsi148 has VMEbus System Controller (SCON) functionality. The SCONEN_ and SCONDIS_ signals are used to control the SCON function. If the SCONEN_ signal is low and the SCONDIS_ signal is high at the rising edge of PUSRTI_, the SCON function is enabled. If the SCONEN_ signal is high and the SCONDIS_ signal is low at the rising edge of PURSTI_, the SCON function is disabled. If the SCONEN_ signal and the SCONDIS_ signal are both high at the rising edge of PUSRTI_, the Auto System Controller feature is used.



The *American National Standard for VME64 Extensions* defines the Auto System Controller feature.

The Auto System Controller feature uses the BG3IN_ signal to enable a board to determine if it is in VMEbus slot 1. If the board is in VMEbus slot 1, the BG3IN_ signal is low and the SCON function is enabled. If the board is not in VMEbus slot 1, the BG3IN_ signal is high and the SCON function is disabled.

Table 10: VMEbus System Controller Configuration

Function	Register	Reset	Sample Signal(s)	Sample State	Description
SCON	VMEbus Status Register	PURSTI_	SCONEN_	0	SCON Enabled
			SCONDIS_	1	
			SCONEN_	1	SCON Disabled
			SCONDIS_	0	
SCONEN_	1	Auto System Controller SCON Enabled			
SCONDIS_	1				
			VBG3IN_	0	
			SCONEN_	1	Auto System Controller SCON DISABLED
			SCONDIS_	1	
			VBG3IN_	1	

6. Interrupt Controller

An interrupt is a process by which a program is informed that an event has occurred in the system (for example, an interrupt signal is asserted to indicate an error). When a program receives an interrupt, it temporarily suspends normal processing and diverts the execution of instructions to a sub-routine handled by an interrupt controller. The controller communicates with the host processor and the device that initiated the interrupt to determine how to handle the interrupt.

Interrupt events originate from a variety of sources; however, they can be classified as one of two types: hardware and software interrupts. Interrupts generated by devices (for example, a printer) indicate an event has occurred and are called hardware interrupts. Interrupt events generated by software programs are called software interrupts.

This chapter discusses the following topics about the Tsi148 interrupt features:

- [“Overview of the Interrupt Controller” on page 138](#)
- [“VMEbus Interrupter” on page 138](#)
- [“Local Interrupter” on page 138](#)
- [“VMEbus Interrupt Handler” on page 139](#)

6.1 Overview of the Interrupt Controller

Tsi148 can be programmed to act as interrupter and an interrupt handler in a VME system. As an interrupter, Tsi148 is capable of asserting interrupts on IRQ[7:1].

As an interrupt handler, Tsi148 has seven VMEbus Interrupt Acknowledge registers which, when read, generate an IACK cycle on the VMEbus (see [Section 10.4.69 on page 310](#)).

6.2 VMEbus Interrupter

Tsi148 has a VMEbus interrupter which enables software to generate VMEbus interrupts. The interrupter operates in Release-on-Acknowledge (ROAK) mode. An 8-bit status/ID is provided upon receiving the IACK cycle.

The following steps illustrate how a VMEbus interrupt is generated:

1. The STATUS/ID and IRQL fields must be set in the VMEbus Interrupt Control (VICR) register. The IRQL field defines the level of VMEbus interrupt output signals (IRQ[7:1]O). A VMEbus interrupt is generated when the IRQL field is written. The interrupter asserts the requested interrupt onto the VMEbus and sets the VMEbus IRQ Status (IRQS) bit in the VMEbus Interrupt Control (VICR) register (see [Section 10.4.69 on page 310](#)).



Only one interrupt at a time can be generated.

2. Once the interrupt is acknowledged the IRQS bit is cleared and the interrupt can be sent to the local bus interrupter (if enabled).

6.3 Local Interrupter

Tsi148's local interrupter provides a mechanism to control the interrupts generated by internal and external sources. The local interrupter receives interrupts from internal and external sources and routes them to one of four interrupt output lines (INTA_, INTB_, INTC_, INTD_).

There are the following internal and external sources of interrupts:

- VMEbus IRQ[7:1]I_
- ACFAILI_
- SFAILI_
- VMEbus Error

- DMA controllers
- VMEbus Interrupter Acknowledged
- VMEbus Edge (Broadcast interrupt, Clock and 64-bit Counter)
- PCI Error
- Mailbox[3:0]
- Location Monitor [3:0]

Each interrupt source has an enable bit, status bit, interrupt out enable bit, and two map bits. The edge sensitive interrupts also have a clear bit. These bits can be programmed in the Tsi148 Interrupt registers (see [Section 10.4.69 on page 310](#)).



The Tsi148 expects the interrupt handling intelligence to exist on the local (PCI/X) bus. The Tsi148 does not have the ability to route local interrupt outputs (INTA_, INTB_, INTC_, INTD_) to VMEbus interrupt outputs (IRQ[7:1]).

6.4 VMEbus Interrupt Handler

Tsi148 has seven VMEbus Interrupt Acknowledge registers which generate an IACK cycle on the VMEbus when they are read. There is one IACK register for each of the VMEbus IRQ[7:1] signals (see [“VMEbus IACK \(1-7\) Registers” on page 247](#)).

The interrupt handler has the following features:

- Supports 8, 16, and 32-bit IACK cycles
 - A word read of the IACK registers causes a 32-bit IACK cycle on the VMEbus
 - A half-word read causes a 16-bit IACK cycle on the VMEbus
 - A byte read causes an 8-bit IACK cycle on the VMEbus
- Once the IACK cycle is generated the interrupter supplies its status/ID.

7. JTAG Module

The Joint Test Action Group (JTAG) created the boundary-scan testing standard (documented in the *IEEE 1149.1 Standard*) for testing printed circuit boards (PCBs). The boundary-scan approach involves designing boundary-scan circuitry into the integrated circuit. PCBs populated with 1149.1 compliant devices can be tested for connectivity, correct device orientation, correct device location, and device identification.

All the pins on compliant devices can be controlled and observed using (typically) five pins that are routed to the board edge connector. Board designers can develop a standard test for all 1149.1 compliant devices regardless of device manufacturer, package type, technology, or device speed.

This chapter discusses the following topics about Tsi148's JTAG features:

- [“Overview of JTAG” on page 142](#)
- [“Instructions” on page 142](#)

7.1 Overview of JTAG

Tsi148 has a dedicated user-accessible JTAG (Joint Test Action Group) module that is fully compatible with the *IEEE 1149.1 Standard Test Access Port and Boundary-Scan Architecture*.

The JTAG logic includes a Test Access Port (TAP) consisting of five dedicated signals (TCK, TRST_, TMS, TDI, TDO), a TAP controller, instruction register, bypass register, other test data registers (for example, device identity register, etc.), and boundary-scan register (see [Figure 32](#)).

Figure 32: JTAG Functional Diagram

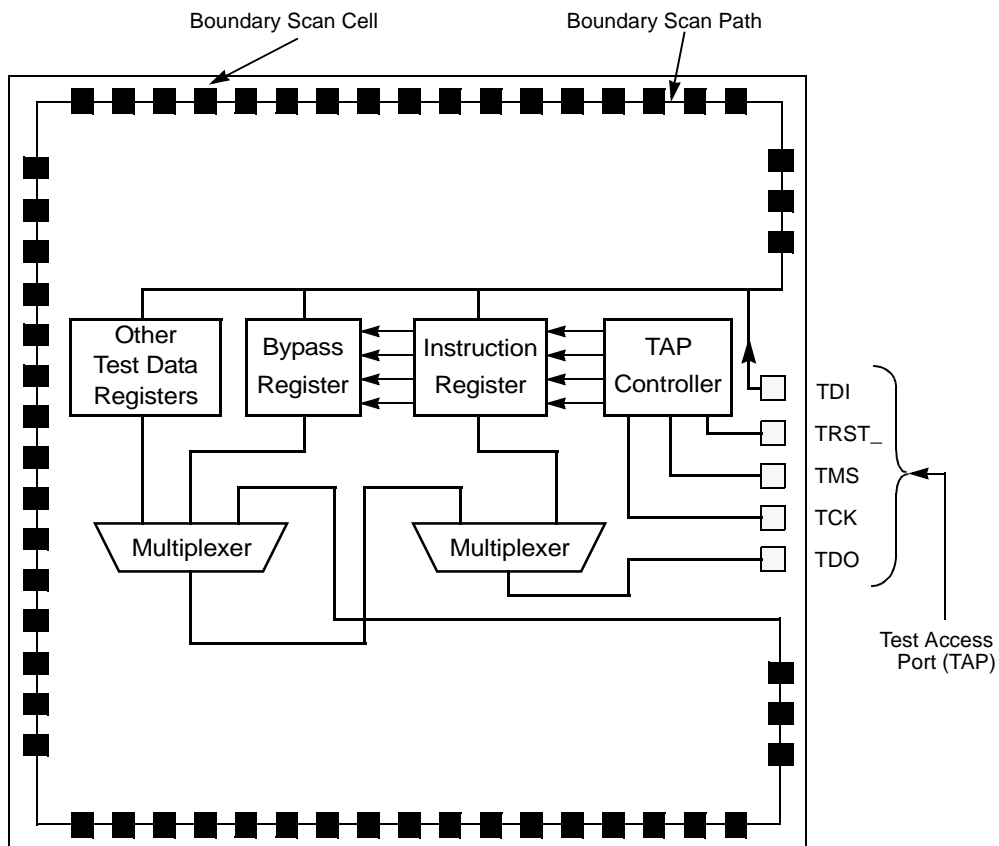

7.2 Instructions

Tsi148's IEEE 1149.1 implementation includes the following instructions:

- **EXTEST:** This instruction drives the data loaded into the boundary scan register through the output pin to drive another chip with the value loaded in the boundary scan cell by the SAMPLE/PRELOAD instruction. At the same time, this instruction also captures the data at the inputs. This process is useful for board interconnect testing.

- **SAMPLE/PRELOAD:** This instruction loads the boundary scan chain with proper values before driving it to another chip using the EXTEST or INTEST instruction.
- **IDCODE:** This instruction configures a 32-bit identification register between the TDI and TDO pins. The instruction selects the ID register and shifts out the identity of the manufacturer, the version, and device identification number. The value of the identification register for revision 1 is 0xxxxxxxxx.
- **BYPASS:** This instruction places a one-bit register between the TDI and TDO pins. This provides a short path through the device for shifting data from one chip to another without going through the boundary scan chain.
- **HIGHZ:** This instruction is the same as BYPASS except that all the bidirect and 3-state outputs are 3-stated when this instruction is active. The boundary scan cell cannot be updated with a new value during this instruction.

8. Signals and Pins

This chapter discusses the following topics about Tsi148's signals:

- “Overview of Signals” on page 145
- “Signal Summary” on page 147
- “Detailed Signal Descriptions” on page 160
- “Pinout” on page 171

8.1 Overview of Signals

The Tsi148 is a 456-pin device. The following sections explain Tsi148's signal groups and characteristics.

8.2 Signal Grouping

The signal grouping is shown in [Figure 33](#).

Figure 33: Signal Grouping

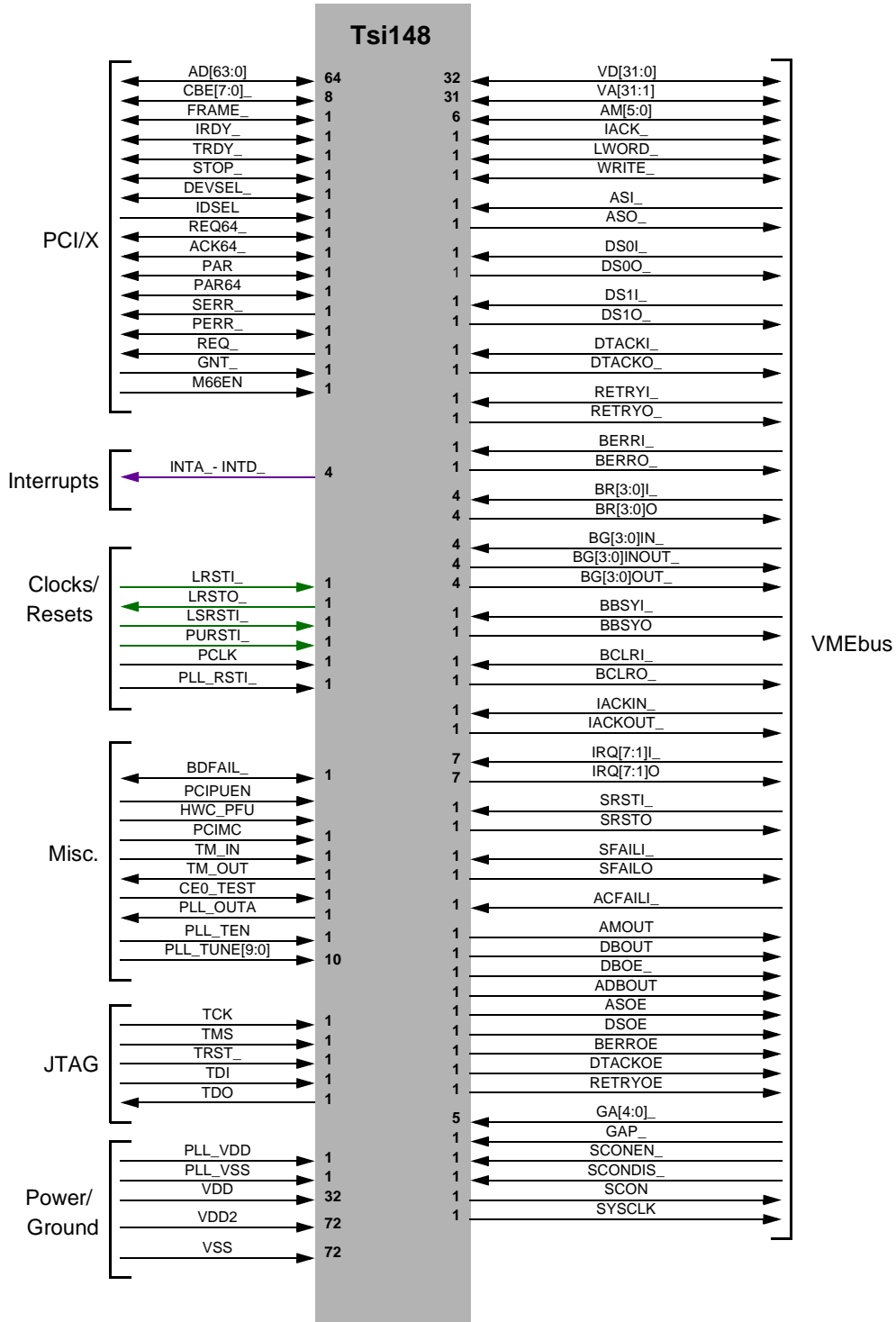

8.3 Signal Summary

The following tables describe the terminology used in [Table 11 on page 147](#).

[Table 11](#) shows the I/O type conventions used for signal descriptions.

Table 11: Signal Conventions - I/O Type

Symbol	Type
Input	Input only
Output	Output only, Totem Pole
Output (t/s)	Output only, Tri-state
Output (o/d)	Output only, Open-drain
Bidirect	Bidirectional, Tri-state
Bidirect (o/d)	Bidirectional, Open-drain

[Table 12](#) shows the I/O level conventions used for signal descriptions. This specifies the DC electrical characteristics of the signal. Refer to [Section 9 on page 185](#) for information on Tsi148's electrical specification.

Table 12: Signal Conventions - I/O Level

Symbol	Type
3.3V TTL	3.3V I/O cell, TTL compliant
5Vtr TTL	3.3V I/O cell, TTL compliant, 5V tolerant
3.3V PCI/X	PCI/PCI-X compliant
1.8V	1.8V I/O cell

Table 13 describes the current capabilities (driver impedance) of the I/O cell. For information on Tsi148's electrical specification, refer to **Section 9 on page 185**.

Table 13: Signal Conventions - I/O Drive

Symbol	Type
35 ohm	Nominal impedance 35 ohms
65 ohm	Nominal impedance 65 ohms
PCI/X	For a 3.3V PCI/X I/O cell, the driver impedance for a point-to-point application is 40 ohms. For a 3.3V PCI/X I/O cell, the driver impedance for a multi-point application is 20 ohms. Driver impedance is controlled by the PCIMC signal.

A signal list summary is shown in **Table 14**.

Table 14: Pin List

Signal	Function	I/O Type	I/O Level	I/O Drive	Pin
AD0	PCI Address/Data Bus [0]	Bidirect	3.3Vttl	PCI-X	AD19
AD1	PCI Address/Data Bus [1]	Bidirect	3.3Vttl	PCI-X	AE18
AD2	PCI Address/Data Bus [2]	Bidirect	3.3Vttl	PCI-X	AF19
AD3	PCI Address/Data Bus [3]	Bidirect	3.3Vttl	PCI-X	AD18
AD4	PCI Address/Data Bus [4]	Bidirect	3.3Vttl	PCI-X	AE17
AD5	PCI Address/Data Bus [5]	Bidirect	3.3Vttl	PCI-X	AF18
AD6	PCI Address/Data Bus [6]	Bidirect	3.3Vttl	PCI-X	AD17
AD7	PCI Address/Data Bus [7]	Bidirect	3.3Vttl	PCI-X	AE16
AD8	PCI Address/Data Bus [8]	Bidirect	3.3Vttl	PCI-X	AD16
AD9	PCI Address/Data Bus [9]	Bidirect	3.3Vttl	PCI-X	AE15
AD10	PCI Address/Data Bus [10]	Bidirect	3.3Vttl	PCI-X	AD15
AD11	PCI Address/Data Bus [11]	Bidirect	3.3Vttl	PCI-X	AE14
AD12	PCI Address/Data Bus [12]	Bidirect	3.3Vttl	PCI-X	AF15
AD13	PCI Address/Data Bus [13]	Bidirect	3.3Vttl	PCI-X	AF14

Table 14: Pin List

Signal	Function	I/O Type	I/O Level	I/O Drive	Pin
AD14	PCI Address/Data Bus [14]	Bidirect	3.3Vttl	PCI-X	AD13
AD15	PCI Address/Data Bus [15]	Bidirect	3.3Vttl	PCI-X	AD14
AD16	PCI Address/Data Bus [16]	Bidirect	3.3Vttl	PCI-X	AF13
AD17	PCI Address/Data Bus [17]	Bidirect	3.3Vttl	PCI-X	AE13
AD18	PCI Address/Data Bus [18]	Bidirect	3.3Vttl	PCI-X	AD12
AD19	PCI Address/Data Bus [19]	Bidirect	3.3Vttl	PCI-X	AE12
AD20	PCI Address/Data Bus [20]	Bidirect	3.3Vttl	PCI-X	AD11
AD21	PCI Address/Data Bus [21]	Bidirect	3.3Vttl	PCI-X	AF10
AD22	PCI Address/Data Bus [22]	Bidirect	3.3Vttl	PCI-X	AE11
AD23	PCI Address/Data Bus [23]	Bidirect	3.3Vttl	PCI-X	AD10
AD24	PCI Address/Data Bus [24]	Bidirect	3.3Vttl	PCI-X	AF9
AD25	PCI Address/Data Bus [25]	Bidirect	3.3Vttl	PCI-X	AD9
AD26	PCI Address/Data Bus [26]	Bidirect	3.3Vttl	PCI-X	AF8
AD27	PCI Address/Data Bus [27]	Bidirect	3.3Vttl	PCI-X	AE9
AD28	PCI Address/Data Bus [28]	Bidirect	3.3Vttl	PCI-X	AD8
AD29	PCI Address/Data Bus [29]	Bidirect	3.3Vttl	PCI-X	AF7
AD30	PCI Address/Data Bus [30]	Bidirect	3.3Vttl	PCI-X	AE8
AD31	PCI Address/Data Bus [31]	Bidirect	3.3Vttl	PCI-X	AD7
AD32	PCI Address/Data Bus [32]	Bidirect	3.3Vttl	PCI-X	Y1
AD33	PCI Address/Data Bus [33]	Bidirect	3.3Vttl	PCI-X	W3
AD34	PCI Address/Data Bus [34]	Bidirect	3.3Vttl	PCI-X	V2
AD35	PCI Address/Data Bus [35]	Bidirect	3.3Vttl	PCI-X	W1
AD36	PCI Address/Data Bus [36]	Bidirect	3.3Vttl	PCI-X	V3
AD37	PCI Address/Data Bus [37]	Bidirect	3.3Vttl	PCI-X	U2
AD38	PCI Address/Data Bus [38]	Bidirect	3.3Vttl	PCI-X	V1
AD39	PCI Address/Data Bus [39]	Bidirect	3.3Vttl	PCI-X	U3

Table 14: Pin List

Signal	Function	I/O Type	I/O Level	I/O Drive	Pin
AD40	PCI Address/Data Bus [40]	Bidirect	3.3Vttl	PCI-X	T2
AD41	PCI Address/Data Bus [41]	Bidirect	3.3Vttl	PCI-X	T3
AD42	PCI Address/Data Bus [42]	Bidirect	3.3Vttl	PCI-X	R2
AD43	PCI Address/Data Bus [43]	Bidirect	3.3Vttl	PCI-X	R3
AD44	PCI Address/Data Bus [44]	Bidirect	3.3Vttl	PCI-X	P2
AD45	PCI Address/Data Bus [45]	Bidirect	3.3Vttl	PCI-X	R1
AD46	PCI Address/Data Bus [46]	Bidirect	3.3Vttl	PCI-X	P1
AD47	PCI Address/Data Bus [47]	Bidirect	3.3Vttl	PCI-X	N3
AD48	PCI Address/Data Bus [48]	Bidirect	3.3Vttl	PCI-X	P3
AD49	PCI Address/Data Bus [49]	Bidirect	3.3Vttl	PCI-X	N1
AD50	PCI Address/Data Bus [50]	Bidirect	3.3Vttl	PCI-X	N2
AD51	PCI Address/Data Bus [51]	Bidirect	3.3Vttl	PCI-X	M3
AD52	PCI Address/Data Bus [52]	Bidirect	3.3Vttl	PCI-X	M2
AD53	PCI Address/Data Bus [53]	Bidirect	3.3Vttl	PCI-X	L3
AD54	PCI Address/Data Bus [54]	Bidirect	3.3Vttl	PCI-X	K1
AD55	PCI Address/Data Bus [55]	Bidirect	3.3Vttl	PCI-X	L2
AD56	PCI Address/Data Bus [56]	Bidirect	3.3Vttl	PCI-X	K3
AD57	PCI Address/Data Bus [57]	Bidirect	3.3Vttl	PCI-X	J1
AD58	PCI Address/Data Bus [58]	Bidirect	3.3Vttl	PCI-X	J3
AD59	PCI Address/Data Bus [59]	Bidirect	3.3Vttl	PCI-X	H1
AD60	PCI Address/Data Bus [60]	Bidirect	3.3Vttl	PCI-X	J2
AD61	PCI Address/Data Bus [61]	Bidirect	3.3Vttl	PCI-X	H3
AD62	PCI Address/Data Bus [62]	Bidirect	3.3Vttl	PCI-X	G1
AD63	PCI Address/Data Bus [63]	Bidirect	3.3Vttl	PCI-X	H2
CBE0_	PCI Command/Byte Enable [0]	Bidirect	3.3Vttl	PCI-X	AF5
CBE1_	PCI Command/Byte Enable [1]	Bidirect	3.3Vttl	PCI-X	AD6

Table 14: Pin List

Signal	Function	I/O Type	I/O Level	I/O Drive	Pin
CBE2_	PCI Command/Byte Enable [2]	Bidirect	3.3Vttl	PCI-X	AE6
CBE3_	PCI Command/Byte Enable [3]	Bidirect	3.3Vttl	PCI-X	AF4
CBE4_	PCI Command/Byte Enable [4]	Bidirect	3.3Vttl	PCI-X	AA3
CBE5_	PCI Command/Byte Enable [5]	Bidirect	3.3Vttl	PCI-X	AB1
CBE6_	PCI Command/Byte Enable [6]	Bidirect	3.3Vttl	PCI-X	Y2
CBE7_	PCI Command/Byte Enable [7]	Bidirect	3.3Vttl	PCI-X	Y3
FRAME_	PCI Cycle Frame	Bidirect	3.3Vttl	PCI-X	AE3
IRDY_	PCI Initiator Ready	Bidirect	3.3Vttl	PCI-X	AD5
TRDY_	PCI Target Ready	Bidirect	3.3Vttl	PCI-X	AF3
STOP_	PCI Stop	Bidirect	3.3Vttl	PCI-X	AE4
DEVSEL_	PCI Device Select	Bidirect	3.3Vttl	PCI-X	AF2
IDSEL	PCI Initialization Device Select	Input	3.3Vttl	PCI-X	AE5
REQ64_	PCI 64-bit Transfer Request	Bidirect	3.3Vttl	PCI-X	AC1
ACK64_	PCI 64-bit Transfer Acknowledge	Bidirect	3.3Vttl	PCI-X	AA2
REQ_	PCI Bus Request	Out(ts)	3.3Vttl	PCI-X	AD2
GNT_	PCI bus Grant	Input	3.3Vttl	PCI-X	AB3
PAR	PCI Bus Parity	Bidirect	3.3Vttl	PCI-X	AE7
PAR64	PCI Bus Parity	Bidirect	3.3Vttl	PCI-X	W2
PERR_	PCI Data Parity Error	Bidirect	3.3Vttl	PCI-X	AB2
SERR_	PCI System Error	Out(od)	3.3Vttl	PCI-X	AC2
M66EN	PCI Frequency Capability Select	Input	3.3Vttl	PCI-X	AD1
PCLK	PCI Clock	Input	3.3Vttl	PCI-X	D7
INTA_	PCI Interrupt A	Out(o/d)	3.3Vttl	35ohm	F3
INTB_	PCI Interrupt B	Out(o/d)	3.3Vttl	35ohm	E1
INTC_	PCI Interrupt C	Out(o/d)	3.3Vttl	35ohm	G2
INTD_	PCI Interrupt D	Out(o/d)	3.3Vttl	35ohm	G3

Table 14: Pin List

Signal	Function	I/O Type	I/O Level	I/O Drive	Pin
LRSTO_	Local Bus Reset Out	Output	3.3Vttl	65ohm	W25
LRSTI_	Local Bus Reset In	Input	3.3Vttl		W23
LSRSTI_	Local SYSRST In	Input	3.3Vttl		Y26
PURSTI_	Power-up Reset In	Input	3.3Vttl		W24
BDFAIL_	Board Fail	Bi(o/d)	3.3Vttl	65ohm	Y24
VA1	VMEbus Address Bus [1]	Bidirect	3.3Vttl	35ohm	K24
VA2	VMEbus Address Bus [2]	Bidirect	3.3Vttl	35ohm	L25
VA3	VMEbus Address Bus [3]	Bidirect	3.3Vttl	35ohm	K26
VA4	VMEbus Address Bus [4]	Bidirect	3.3Vttl	35ohm	L23
VA5	VMEbus Address Bus [5]	Bidirect	3.3Vttl	35ohm	L24
VA6	VMEbus Address Bus [6]	Bidirect	3.3Vttl	35ohm	M25
VA7	VMEbus Address Bus [7]	Bidirect	3.3Vttl	35ohm	N23
VA8	VMEbus Address Bus [8]	Bidirect	3.3Vttl	35ohm	M24
VA9	VMEbus Address Bus [9]	Bidirect	3.3Vttl	35ohm	M23
VA10	VMEbus Address Bus [10]	Bidirect	3.3Vttl	35ohm	N25
VA11	VMEbus Address Bus [11]	Bidirect	3.3Vttl	35ohm	M26
VA12	VMEbus Address Bus [12]	Bidirect	3.3Vttl	35ohm	N26
VA13	VMEbus Address Bus [13]	Bidirect	3.3Vttl	35ohm	P24
VA14	VMEbus Address Bus [14]	Bidirect	3.3Vttl	35ohm	N24
VA15	VMEbus Address Bus [15]	Bidirect	3.3Vttl	35ohm	P26
VA16	VMEbus Address Bus [16]	Bidirect	3.3Vttl	35ohm	R26
VA17	VMEbus Address Bus [17]	Bidirect	3.3Vttl	35ohm	P25
VA18	VMEbus Address Bus [18]	Bidirect	3.3Vttl	35ohm	R24
VA19	VMEbus Address Bus [19]	Bidirect	3.3Vttl	35ohm	R23

Table 14: Pin List

Signal	Function	I/O Type	I/O Level	I/O Drive	Pin
VA20	VMEbus Address Bus [20]	Bidirect	3.3Vttl	35ohm	P23
VA21	VMEbus Address Bus [21]	Bidirect	3.3Vttl	35ohm	R25
VA22	VMEbus Address Bus [22]	Bidirect	3.3Vttl	35ohm	T24
VA23	VMEbus Address Bus [23]	Bidirect	3.3Vttl	35ohm	T23
VA24	VMEbus Address Bus [24]	Bidirect	3.3Vttl	35ohm	U26
VA25	VMEbus Address Bus [25]	Bidirect	3.3Vttl	35ohm	T25
VA26	VMEbus Address Bus [26]	Bidirect	3.3Vttl	35ohm	U24
VA27	VMEbus Address Bus [27]	Bidirect	3.3Vttl	35ohm	V26
VA28	VMEbus Address Bus [28]	Bidirect	3.3Vttl	35ohm	U23
VA29	VMEbus Address Bus [29]	Bidirect	3.3Vttl	35ohm	U25
VA30	VMEbus Address Bus [30]	Bidirect	3.3Vttl	35ohm	V24
VA31	VMEbus Address Bus [31]	Bidirect	3.3Vttl	35ohm	W26
VD0	VMEbus Data Bus [0]	Bidirect	3.3Vttl	35ohm	D6
VD1	VMEbus Data Bus [1]	Bidirect	3.3Vttl	35ohm	A4
VD2	VMEbus Data Bus [2]	Bidirect	3.3Vttl	35ohm	B6
VD3	VMEbus Data Bus [3]	Bidirect	3.3Vttl	35ohm	B7
VD4	VMEbus Data Bus [4]	Bidirect	3.3Vttl	35ohm	C7
VD5	VMEbus Data Bus [5]	Bidirect	3.3Vttl	35ohm	D8
VD6	VMEbus Data Bus [6]	Bidirect	3.3Vttl	35ohm	D9
VD7	VMEbus Data Bus [7]	Bidirect	3.3Vttl	35ohm	B9
VD8	VMEbus Data Bus [8]	Bidirect	3.3Vttl	35ohm	A8
VD9	VMEbus Data Bus [9]	Bidirect	3.3Vttl	35ohm	C9
VD10	VMEbus Data Bus [10]	Bidirect	3.3Vttl	35ohm	B10
VD11	VMEbus Data Bus [11]	Bidirect	3.3Vttl	35ohm	B11
VD12	VMEbus Data Bus [12]	Bidirect	3.3Vttl	35ohm	A10
VD13	VMEbus Data Bus [13]	Bidirect	3.3Vttl	35ohm	D11

Table 14: Pin List

Signal	Function	I/O Type	I/O Level	I/O Drive	Pin
VD14	VMEbus Data Bus [14]	Bidirect	3.3Vttl	35ohm	C11
VD15	VMEbus Data Bus [15]	Bidirect	3.3Vttl	35ohm	B12
VD16	VMEbus Data Bus [16]	Bidirect	3.3Vttl	35ohm	D13
VD17	VMEbus Data Bus [17]	Bidirect	3.3Vttl	35ohm	C12
VD18	VMEbus Data Bus [18]	Bidirect	3.3Vttl	35ohm	D12
VD19	VMEbus Data Bus [19]	Bidirect	3.3Vttl	35ohm	B13
VD20	VMEbus Data Bus [20]	Bidirect	3.3Vttl	35ohm	A12
VD21	VMEbus Data Bus [21]	Bidirect	3.3Vttl	35ohm	A13
VD22	VMEbus Data Bus [22]	Bidirect	3.3Vttl	35ohm	C14
VD23	VMEbus Data Bus [23]	Bidirect	3.3Vttl	35ohm	C13
VD24	VMEbus Data Bus [24]	Bidirect	3.3Vttl	35ohm	A14
VD25	VMEbus Data Bus [25]	Bidirect	3.3Vttl	35ohm	A15
VD26	VMEbus Data Bus [26]	Bidirect	3.3Vttl	35ohm	B14
VD27	VMEbus Data Bus [27]	Bidirect	3.3Vttl	35ohm	C15
VD28	VMEbus Data Bus [28]	Bidirect	3.3Vttl	35ohm	D15
VD29	VMEbus Data Bus [29]	Bidirect	3.3Vttl	35ohm	D14
VD30	VMEbus Data Bus [30]	Bidirect	3.3Vttl	35ohm	B15
VD31	VMEbus Data Bus [31]	Bidirect	3.3Vttl	35ohm	C16
AM0	VMEbus AM Bus [0]	Bidirect	3.3Vttl	35ohm	H24
AM1	VMEbus AM Bus [1]	Bidirect	3.3Vttl	35ohm	J23
AM2	VMEbus AM Bus [2]	Bidirect	3.3Vttl	35ohm	J25
AM3	VMEbus AM Bus [3]	Bidirect	3.3Vttl	35ohm	H26
AM4	VMEbus AM Bus [4]	Bidirect	3.3Vttl	35ohm	J24
AM5	VMEbus AM Bus [5]	Bidirect	3.3Vttl	35ohm	K25
IACK_	VMEbus Interrupt Acknowledge	Bidirect	3.3Vttl	35ohm	G26
WRITE_	VMEbus Write	Bidirect	3.3Vttl	35ohm	K23

Table 14: Pin List

Signal	Function	I/O Type	I/O Level	I/O Drive	Pin
LWORD_	VMEbus Long Word	Bidirect	3.3Vttl	35ohm	J26
ASI_	VMEbus Address Strobe In	Input	3.3Vttl		G23
ASO_	VMEbus Address Strobe Out	Output	3.3Vttl	35ohm	F24
DS0I_	VMEbus Data Strobe 0 In	Input	3.3Vttl		E25
DS0O_	VMEbus Data Strobe 0 Out	Output	3.3Vttl	35ohm	D25
DS1I_	VMEbus Data Strobe 1 In	Input	3.3Vttl		D26
DS1O_	VMEbus Data Strobe 1 Out	Output	3.3Vttl	35ohm	F23
DTACKI_	VMEbus Data Acknowledge In	Input	3.3Vttl		E23
DTACKO_	VMEbus Data Acknowledge Out	Output	3.3Vttl	35ohm	D24
RETRYI_	VMEbus Retry In	Input	3.3Vttl		H25
RETRYO_	VMEbus Retry Out	Output	3.3Vttl	35ohm	H23
BERRI_	VMEbus Bus Error In	Input	3.3Vttl		C22
BERRO_	VMEbus Bus Error Out	Output	3.3Vttl	35ohm	A24
BR0I_	VMEbus Bus Request 0 In	Input	5Vtlrnt		D20
BR0O	VMEbus Bus Request 0 Out	Output	3.3Vttl	35ohm	B20
BR1I_	VMEbus Bus Request 1 In	Input	5Vtlrnt		C21
BR1O	VMEbus Bus Request 1 Out	Output	3.3Vttl	35ohm	A22
BR2I_	VMEbus Bus Request 2 In	Input	5Vtlrnt		A23
BR2O	VMEbus Bus Request 2 Out	Output	3.3Vttl	35ohm	B21
BR3I_	VMEbus Bus Request 3 In	Input	5Vtlrnt		B22
BR3O	VMEbus Bus Request 3 Out	Output	3.3Vttl	35ohm	D21
BG0IN_	VMEbus Bus Grant 0 In	Input	5Vtlrnt		B17
BG1IN_	VMEbus Bus Grant 1 In	Input	5Vtlrnt		B18
BG2IN_	VMEbus Bus Grant 2 In	Input	5Vtlrnt		A20
BG3IN_	VMEbus Bus Grant 3 In	Input	5Vtlrnt		C20
BG0INOUT_	VMEbus Bus Grant 0 In/Out	Out(t/s)	5Vtlrnt	35ohm	D17

Table 14: Pin List

Signal	Function	I/O Type	I/O Level	I/O Drive	Pin
BG1INOUT_	VMEbus Bus Grant 1 In/Out	Out(t/s)	5VtIrnT	35ohm	A19
BG2INOUT_	VMEbus Bus Grant 2 In/Out	Out(t/s)	5VtIrnT	35ohm	C19
BG3INOUT_	VMEbus Bus Grant 3 In/Out	Out(t/s)	5VtIrnT	35ohm	D19
BG0OUT_	VMEbus Bus Grant 0 Out	Output	5VtIrnT	35ohm	A18
BG1OUT_	VMEbus Bus Grant 1 Out	Output	5VtIrnT	35ohm	C18
BG2OUT_	VMEbus Bus Grant 2 Out	Output	5VtIrnT	35ohm	D18
BG3OUT_	VMEbus Bus Grant 3 Out	Output	5VtIrnT	35ohm	B19
BBSYI_	VMEbus Bus Busy In	Input	3.3VtI		A17
BBSYO	VMEbus Bus Busy Out	Output	3.3VtI	35ohm	D16
BCLRI_	VMEbus Bus Clear In	Input	3.3VtI		C17
BCLRO_	VMEbus Bus Clear Out	Output	3.3VtI	35ohm	B16
IACKIN_	VMEbus Interrupt Acknowledge In	Input	5VtIrnT		G25
IACKOUT_	VMEbus Interrupt Acknowledge Out	Output	5VtIrnT	35ohm	E26
IRQ1I_	VMEbus Interrupt Request 1 In	Input	5VtIrnT		AA25
IRQ1O	VMEbus Interrupt Request 1 Out	Output	3.3VtI	65ohm	AC26
IRQ2I_	VMEbus Interrupt Request 2 In	Input	5VtIrnT		AC25
IRQ2O	VMEbus Interrupt Request 2 Out	Output	3.3VtI	65ohm	AA23
IRQ3I_	VMEbus Interrupt Request 3 In	Input	5VtIrnT		AB24
IRQ3O	VMEbus Interrupt Request 3 Out	Output	3.3VtI	65ohm	AD26
IRQ4I_	VMEbus Interrupt Request 4 In	Input	5VtIrnT		AD25
IRQ4O	VMEbus Interrupt Request 4 Out	Output	3.3VtI	65ohm	AC24
IRQ5I_	VMEbus Interrupt Request 5 In	Input	5VtIrnT		AD23
IRQ5O	VMEbus Interrupt Request 5 Out	Output	3.3VtI	65ohm	AD22
IRQ6I_	VMEbus Interrupt Request 6 In	Input	5VtIrnT		AE23
IRQ6O	VMEbus Interrupt Request 6 Out	Output	3.3VtI	65ohm	AF24
IRQ7I_	VMEbus Interrupt Request 7 In	Input	5VtIrnT		AE21

Table 14: Pin List

Signal	Function	I/O Type	I/O Level	I/O Drive	Pin
IRQ7O	VMEbus Interrupt Request 7 Out	Output	3.3Vttl	65ohm	AF23
SRSTI_	VMEbus System Reset In	Input	5Vtlrnt		AB26
SRSTO	VMEbus System Reset Out	Output	3.3Vttl	65ohm	Y25
SFAILI_	VMEbus System Fail In	Input	5Vtlrnt		AA24
SFAILO	VMEbus System Fail Out	Output	3.3Vttl	65ohm	Y23
ACFAILI_	VMEbus AC Fail In	Input	5Vtlrnt		V23
GA0_	Geographic Address [0]	Input	3.3Vttl		AF22
GA1_	Geographic Address [1]	Input	3.3Vttl		AE20
GA2_	Geographic Address [2]	Input	3.3Vttl		AD20
GA3_	Geographic Address [3]	Input	3.3Vttl		AE19
GA4_	Geographic Address [4]	Input	3.3Vttl		AF20
GAP_	Geographic Address Parity	Input	3.3Vttl		AD21
SYSCLK	VMEbus System Clock	Output	3.3Vttl	35ohm	E24
AMOUT	VMEbus Address Bus Out	Output	3.3Vttl	35ohm	B24
DBOUT	VMEbus Data Bus Out	Output	3.3Vttl	35ohm	D22
ADBOUT	VMEbus A/D Bus Out	Output	3.3Vttl	35ohm	A25
DBOE_	VMEbus Data bus OE	Output	3.3Vttl	35ohm	C23
ASOE	VMEbus Address Strobe OE	Output	3.3Vttl	35ohm	F25
DSOE	VMEbus Data Strobe OE	Output	3.3Vttl	35ohm	C26
DTACKOE	VMEbus Data Acknowledge OE	Output	3.3Vttl	35ohm	C25
BERROE	VMEbus Bus Error OE	Output	3.3Vttl	35ohm	B23
RETRYOE	VMEbus Retry OE	Output	3.3Vttl	35ohm	G24
SCONEN_	System Controller Enable	Input	3.3Vttl		E3
SCONDIS_	System Controller Disable	Input	3.3Vttl		C2
SCON	System Controller	Output	3.3Vttl	65ohm	B1

Table 14: Pin List

Signal	Function	I/O Type	I/O Level	I/O Drive	Pin
TCK	JTAG Clock	Input	3.3Vttl		D2
TMS	JTAG Mode Select	Input	3.3Vttl		E2
TDI	JTAG Data In	Input	3.3Vttl		C1
TDO	JTAG Data Out	Output	3.3Vttl	65ohm	F2
TRST_	JTAG Reset	Input	3.3Vttl		D1
CEO_TEST	Factory Test Note: This signal is used during factory test and should be pulled low.	Input	1.8V		AE22
PCIMC	PCI Driver Mode Control	Input	3.3Vttl		AB25
HWC_PFU	Float PCI Upper Signals	Input	3.3Vttl		AD4
PCIPUEN	PCI Pullup Enable	Input	3.3Vttl		AC3
PLL_TEN	Enable PLL Tune	Input	3.3Vttl		B5
TM_IN	Temperature Monitor In				AB23
TM_OUT	Temperature Monitor Out				AE26
PLL_RSTI_	PLL Reset In	Input	3.3Vttl		D5
PLL_TUNE0	PLL Tune 0	input	3.3Vttl		C10
PLL_TUNE1	PLL Tune 1	input	3.3Vttl		D10
PLL_TUNE2	PLL Tune 2	input	3.3Vttl		C8
PLL_TUNE3	PLL Tune 3	input	3.3Vttl		B8
PLL_TUNE4	PLL Tune 4	input	3.3Vttl		A5
PLL_TUNE5	PLL Tune 5	input	3.3Vttl		C6
PLL_TUNE6	PLL Tune 6	input	3.3Vttl		B4
PLL_TUNE7	PLL Tune 7	input	3.3Vttl		A3
PLL_TUNE8	PLL Tune 8	input	3.3Vttl		C4
PLL_TUNE9	PLL Tune 9	input	3.3Vttl		B3
PLL_OUTA	PLL Output	Output	1.8V	65ohm	C5
PLL_VDD	PLL 1.8V Analog Supply	Input			A7

Table 14: Pin List

Signal	Function	I/O Type	I/O Level	I/O Drive	Pin
PLL_VSS	PLL Analog Ground	Input			A9
VDD18	1.8V Digital Supply	Inputs	E5, E10, E11, E12, E15, E16, E17, E22, K5, K22, L5, L22, M5, M22, R5, R22, T5, T22, U5, U22, AB5, AB10, AB11, AB12, AB15, AB16, AB17, AB22, M14, N12, P15, R13		
VDD33	3.3V Digital Supply	Inputs	E4, E6, E7, E8, E13, E19, E20, E21, F4, F5, F22, G4, G5, G22, H4, H5, H22, J4, K4, L4, M4, N4, N22, P4, P5, R4, T4, U4, V4, W4, W5, W22, Y4, Y5, Y22, AA4, AA5, AA22, AB14, AB19, AB20, AB21, AB4, AB6, AB7, AB8, AC5, AC6, AC7, AC8, AC9, AC10, AC11, AC12, AC13, AC14, AC15, AC16, AC17, AC18, AC19, AC20, AC21, AC22, L12, L15, M11, M16, R11, R16, T12, T15		
VSS	Digital Ground	Inputs	A1, A2, A6, A11, A16, A21, A26, B2, B25, B26, C3, C24, D4, D23, E9, E14, E18, F1, F26, J5, J22, L1, L26, N5, P22, T1, T26, V5, V22, AA1, AA26, AB9, AB13, AB18, AC4, AC23, AD3, AD24, AE1, AE2, AE25, AF1, AF6, AF11, AF16, AF21, AF25, AF26, L11, L13, L14, L16, M12, M13, M15, N11, N13, N14, N15, N16, P11, P12, P13, P14, P16, R12, R14, R15, T11, T13, T14, T16		
Spares	Unused pins	N/A			

8.4 Detailed Signal Descriptions

This section describes individual signals.

8.4.1 PCI/X Signal Descriptions

The PCI/X Interface is designed to be connected directly to any 3.3V, 32-bit or 64-bit PCI or PCI-X bus. The timing and functionality of all PCI/X signals is with respect to the PCLK clock signal.

All PCI/X signals detailed in the pinout ([Table 17 on page 172](#)) are compliant with the *PCI Local Bus Specification* (Revision 2.2) and the *PCI-X Addendum to PCI Local Bus Specification* (Revision 1.0b). For detailed descriptions of the operations of the signals, please refer to the specifications.

8.4.2 VMEbus Signal Descriptions

The Tsi148 VME Interface is designed to be connected to the VMEbus through external buffers. Refer to the *American National Standard for VME64*, *American National Standard for VME64 Extensions*, and *Source Synchronous Transfer (2eSST) Standard* documents for a complete description of the VMEbus.

Table 15: VMEbus Signal Descriptions

Signal Group	Signal Name	Active	I/O	Description	Buffer Requirements
Data Transfer	VA[31:1] Address	High	I	The VMEbus address signals are monitored by the VME Slave. During MBLT transfers, the address lines are used to transfer data.	These signals are connected to the VMEbus through external bidirectional buffers. Since LWORD_ is also used to transfer data, it should be included in the same buffer group as the VMEbus address signals.
			O	The VMEbus address signals are driven by Tsi148 when it is the VME Master. During MBLT transfers, the address lines are used to transfer data.	
	VD[31:0] DATA	High	I	The VMEbus data signals are used to receive data from the VMEbus during master read cycles and slave write cycles. They are also used to receive address information during A64 cycles.	These signals are connected to the VMEbus through external bidirectional buffers.
			O	The VMEbus data signals are driven by Tsi148 to transmit data during master write cycles and slave read cycles. They are also used to transmit address information during A64 cycles.	
	AM[5:0] Address Modifier	High	I	The VMEbus address modifier signals are monitored by the VME Slave.	These signals are connected to the VMEbus through an external bidirectional buffer. WRITE_ and IACK_ should be included in the same buffer.
			O	The VMEbus address modifier signals are driven by Tsi148 when it is the VME Master.	

Table 15: VMEbus Signal Descriptions

Signal Group	Signal Name	Active	I/O	Description	Buffer Requirements
Data Transfer	LWORD_ Long Word	Low	I	The LWORD_ signal is monitored by the VME Slave. The LWORD_ signal is also used as a data signal during MBLT transfers.	This signal is connected to the VMEbus through an external bidirectional buffer. LWORD_ should be included in the same buffer group as the VMEbus address signals.
			O	The LWORD_ signal is driven by Tsi148 when it is the VME Master. The LWORD_ signal is also used as a data signal during MBLT transfers.	
	IACK_ Interrupt Acknowledge	Low	I	The IACK_ signal is monitored by the VME Slave.	This signal is connected to the VMEbus through an external bidirectional buffer. IACK_ should be included in the same buffer as the AM and WRITE_ signals.
			O	The LWORD_ signal is driven by Tsi148 when it is the VME Master.	
	WRITE_ Write	Low	I	The WRITE_ signal is monitored by the VME Slave.	This signal is connected to the VMEbus through an external bidirectional buffer. WRITE_ should be included in the same buffer as the AM and IACK_ signals.
			O	The WRITE_ signal is driven by Tsi148 when it is the VME Master.	
	ASI_ Address Strobe Input	Low	I	The ASI_ signal is monitored by the VVME Master and VME Slave.	This signal is received from the VMEbus with an external non-inverting buffer.

Table 15: VMEbus Signal Descriptions

Signal Group	Signal Name	Active	I/O	Description	Buffer Requirements
Data Transfer	ASO_ Address Strobe Output	Low	O	The ASO_ signal is driven by Tsi148 when it is the VME Master.	This signal is connected to the VMEbus through an external tri-state buffer.
	DS0I_ Data Strobe 0 Input	Low	I	VMEbus data strobe 0 is monitored by Tsi148's VME Slave.	This signal is received from the VMEbus with an external non-inverting buffer.
	DS0O_ Data Strobe 0 Output	Low	O	VMEbus data strobe 0 is driven by Tsi148 during VME Master cycles.	This signal is connected to the VMEbus through an external tri-state buffer.
	DS1I_ Data Strobe 1 Input	Low	I	VMEbus data strobe 1 is monitored by Tsi148 VME Slave.	This signal is received from the VMEbus with an external non-inverting buffer.
	DS1O_ Data Strobe 1 Output	Low	O	VMEbus data strobe 1 is driven by Tsi148 during VME Master cycles.	This signal is connected to the VMEbus through an external tri-state buffer.
	DTACKI_ Data Acknowledge Input	Low	I	The VMEbus data acknowledge is monitored by Tsi148's VME Master.	This signal is received from the VMEbus with an external non-inverting buffer.
	DTACKO_ Data Acknowledge Output	Low	O	The VMEbus data acknowledge is driven by Tsi148's VME Slave.	This signal is connected to the VMEbus through an external tri-state buffer.
	RETRYI_ Retry Input	Low	I	The VMEbus retry is monitored by Tsi148's VME Master.	This signal is received from the VMEbus with an external non-inverting buffer.
	RETRYO_ Retry Output	Low	O	The VMEbus retry is driven by Tsi148's VME Slave	This signal is connected to the VMEbus through an external tri-state buffer.

Table 15: VMEbus Signal Descriptions

Signal Group	Signal Name	Active	I/O	Description	Buffer Requirements
Data Transfer	BERRI_ Bus Error Input	Low	I	The VMEbus bus error is monitored by Tsi148's VME Master.	This signal is received from the VMEbus with an external non-inverting buffer.
	BERRO_ Bus Error Output	Low	O	The VMEbus bus error is driven by Tsi148's VME Slave and global time-out timer.	This signal is connected to the VMEbus through an external tristate buffer.
Arbitration	BR[3:0]_ Bus Request Input	Low	I	The VMEbus bus request signals are monitored by Tsi148's VMEbus arbiter and requester.	These signals are 5 volt tolerant and may be connected directly to the VMEbus.
	BR[3:0]O Bus Request Output	High	O	The VMEbus bus request signals are driven by Tsi148's VMEbus requester.	These signals are connected to the VMEbus through external inverting open collector buffers.
	BG[3:0]IN_ Bus Grant Input	Low	I	The VMEbus bus grant in signals are monitored by Tsi148's VMEbus requester.	These signals are 5 volt tolerant and may be connected directly to the VMEbus.
	BG[3:0]INOUT_ Bus Grant Input	Low	O	The VMEbus standard requires board in slot 1 to drive the bus grant in signals as outputs. These signals are connected to the BG[3:0]IN_ signals. Separate signals are provided to allow for external buffers.	These signals are 5 volt tolerant and may be connected directly to the VMEbus. These signals may be connected to the VMEbus BG[3:0]IN_ signals through external tri-state drivers. When external drivers are used, SCON is the enable signal.
	BG[3:0]OUT_ Bus Grant Input	Low	O	The VMEbus grant out signals are driven by Tsi148's VMEbus requester.	These signals are 5 volt tolerant and may be connected directly to the VMEbus.

Table 15: VMEbus Signal Descriptions

Signal Group	Signal Name	Active	I/O	Description	Buffer Requirements
Arbitration	BBSYI_ Bus Busy Input	Low	I	The VMEbus bus busy signal is monitored by Tsi148's VMEbus requester and arbiter.	This signal is received from the VMEbus with an external non-inverting buffer.
	BBSYO Bus Busy Output	High	O	The VMEbus bus busy signal is driven by Tsi148's VMEbus requester.	This signal is connected to the VMEbus through an external inverting open collector buffer.
	BCLRI_ Bus Clear Input	Low	I	The VMEbus bus clear signal is monitored by Tsi148's VVME Master.	This signal is received from the VMEbus with an external non-inverting buffer.
	BCLRO_ Bus Clear Output	Low	O	The VMEbus bus clear signal is driven by Tsi148's VMEbus arbiter.	This signal is connected to the VMEbus through an external tri-state buffer.
Interrupt	IACKIN_ Interrupt Acknowledge Input	Low	I	The VMEbus interrupt acknowledge in signal is monitored by Tsi148's VMEbus interrupter.	This signal is 5 volt tolerant and may be connected directly to the VMEbus.
	IACKOUT_ Interrupt Acknowledge Output	Low	O	The VMEbus interrupt acknowledge out signal is driven by Tsi148's VMEbus interrupter.	This signal is 5 volt tolerant and may be connected directly to the VMEbus.
	IRQ[7:1]I_ Interrupt Input	Low	I	The VMEbus interrupt request signals are monitored by Tsi148's VMEbus interrupt handler.	These signals are 5 volt tolerant and may be connected directly to the VMEbus.
	IRQ[7:1]O Interrupt Output	High	O	The VMEbus interrupt request signals are driven by Tsi148's VMEbus interrupter.	These signals are connected to the VMEbus through external inverting open collector buffers.

Table 15: VMEbus Signal Descriptions

Signal Group	Signal Name	Active	I/O	Description	Buffer Requirements
Utility	SRSTI_ System Reset Input	Low	I	The VMEbus system reset signal is used to reset the VMEbus logic. It causes the LRSTO_ signal to be asserted which causes a local bus reset.	This signal is 5 volt tolerant and may be connected directly to the VMEbus.
	SRSTO System Reset Output	High	O	The VMEbus system reset signal is driven to reset the VMEbus.	This signal is connected to the VMEbus through an external inverting open collector buffer.
	SFAILI_ System Fail Input	Low	I	The VMEbus system fail signal is monitored by Tsi148's interrupter logic. If enabled, an interrupt is generated on the falling edge of SFAILI_.	This signal is 5 volt tolerant and may be connected directly to the VMEbus.
	SFAILO System Fail Output	High	O	The VMEbus system fail signal is driven by Tsi148 when the BDFAIL_ signal is asserted and the SYSFAIL signal is not inhibited.	This signal is connected to the VMEbus through an external inverting open collector buffer.
	ACFAILI_ AC Fail Input	Low	I	The VMEbus AC fail signal is monitored by Tsi148's interrupter logic. If enabled, an interrupt is generated on the falling edge of ACFAILI_.	This signal is 5 volt tolerant and may be connected directly to the VMEbus.
	SYSCLK System Clock Output		O	The system clock signal is driven by Tsi148 when the system controller function is enable.	This signal is connected to the VMEbus through an external tri-state buffer.
Utility	GA[4:0]_ Geographic Address Input	Low	I	These signals are connected to the geographic address signals on the VMEbus.	Since these signals are either grounded or open on the backplane, they can be connected directly to Tsi148.
	GAP_ Geographic Address Parity Input	Low	I	This signal is connected to the geographic address parity signal on the VMEbus.	Since this signal is either grounded or open on the backplane, it can be connected directly to Tsi148.

Table 15: VMEbus Signal Descriptions

Signal Group	Signal Name	Active	I/O	Description	Buffer Requirements
Buffer Control	AMOUT Address Bus Out	High	O	This signal is used to control the direction of the external buffers on the AM, IACK_ and WRITE_ signals.	
	DBOUT Data Bus Out	High	O	This signal is used to control the direction of the external buffers on the D bus signals.	
	DBOE_ Data Bus Output Enable	Low	O	This signal is used to control the enable of the external buffers on the D bus, A bus and LWORD_ signals.	
	ADBOU Address/Data Bus Out	High	O	This signal is used to control the direction of the external buffers on the A bus and LWORD_ signals. These signal are used to transfer data during MBLT transfers.	
	ASOE Address Strobe Output Enable	High	O	This signal is used to enable the address strobe driver.	
	DSOE Data Strobe Output Enable	High	O	This signal is used to enable the data strobe 0 and 1 drivers.	
	DTACKOE Data Transfer Acknowledge Output Enable	High	O	This signal is used to enable the data transfer acknowledge driver.	
	BERROE Bus Error Output Enable	High	O	This signal is used to enable the bus error driver.	
	RETRYOE Retry Output Enable	High	O	This signal is used to enable the Retry driver.	

Table 15: VMEbus Signal Descriptions

Signal Group	Signal Name	Active	I/O	Description	Buffer Requirements
Buffer Control	SCON System Controller Enabled	High	O	This signal is asserted when the system controller function is enabled. This signal is used to enable the BCLR_ and SYSCLK drivers.	
Configuration	SCONEN_ System Controller Enable	Low	I	When this signal is asserted and the SCONDIS_ signal is negated. The system controller functions are enabled. When SCONEN_ and SCONDIS_ signals are negated, the auto SCON function is enabled.	
	SCONDIS_ System Controller Disable	Low	I	When this signal is asserted and the SCONEN_ signal is negated. The system controller functions are disabled. When SCONEN_ and SCONDIS_ signals are negated, the auto SCON function is enabled.	

8.4.3 Miscellaneous Signal Descriptions

Table 16: Miscellaneous Signal Descriptions

Signal Group	Signal Name	Active	I/O	Description
Utility	BDFAIL_ Board Fail	Low	I/O	When this signal is asserted, the SFAILO signal is asserted if the SYSFAIL inhibit bit is not set.

Table 16: Miscellaneous Signal Descriptions

Signal Group	Signal Name	Active	I/O	Description
Reset Control	LRSTI_ Local Reset Input	Low	I	When this signal is asserted, the PCI bus internal logic is reset. This signal should be connected to the boards local bus reset signal.
	LRSTO_ Local Reset Output	Low	O	When this signal is asserted, the PCI bus logic on the board should be reset. This signal should be combined with other reset signals to generate the local bus reset signal.
	LSRSTI_ Local System Reset Input	Low	I	When this signal is asserted, the LRSTO signal is asserted. This signal allows on board logic to generate a VMEbus system reset.
	PURSTI_ Power Up Reset Input	Low	I	PURSTI_ is asserted at power up.
Interrupt	INTA_ - INTD_	Low	O	These pins are the PCI bus interrupt outputs.
Hardware Configuration	HWC_PFU	High	I	When Tsi148 is configured in 32-bit PCI mode and this signal is low, the 64-bit extension signals are driven. When Tsi148 is configured in 32-bit PCI mode and this signal is high, the 64-bit extension signals are tri-stated.
	PCIPUEN	High	I	When this signal is asserted, the internal PCI bus pull ups are enable. When this signal is negated, the internal PCI bus pull ups are disabled.
	PCIMC	High	I	When this signal is asserted, the PCI drivers are configured with a 40 ohm impedance for point-to-point operation. When this signal is negated, the PCI drivers are configured with a 20 ohm impedance for multi-point operation.
PLL	PLL_TEN	High	I	When this signal is high, the PLL_TUNE signals are used to tune the PLL.
	PLL_TUNE [9:0]	High	I	When the PLL_TEN signal is asserted, these signals are used to tune the PLL. When PLL_TEN signal is negated, the PLL tune bits are internally controlled.
	PLL_RSTI_	Low	I	When this signal is asserted, the PLL is reset.
	PLL_OUTA	-	-	PLL Output: This output is internally disabled.

Table 16: Miscellaneous Signal Descriptions

Signal Group	Signal Name	Active	I/O	Description
Temperature	TM_IN			The TM_IN and TM_OUT signals can be used to measure the die temperature.
	TN_OUT			
Test	TCK	High	I	This signal is used to clock state information and test data into and out of Tsi148 during IEEE 1149.1 test operation.
	TMS	High	I	This signal is used to control the state of the TAP controller during IEEE 1149.1 test operation.
	TDI	High	I	This signal is used to serially shift test data and test instructions into Tsi148 during IEEE 1149.1 test operation.
	TDO	High	O	This signal is used to serially shift test data and test instructions out of Tsi148 during IEEE 1149.1 test operation.
	TRST_	Low	I	This signal provides an asynchronous initialization of the IEEE 1149.1 compliant TAP controller. This signal must be tied to ground if JTAG is not used in the system. If JTAG is used in the system, the TRST_ input must be asserted low at the negation of the PURSTI_ input and then held high during boundary scan testing.
	CEO_TEST	High	I	This signal is used during factory test. It should be pulled down on the PWB.
Power	VDD2		I	The +3.3V pins provide power for the I/O buffers.
	VDD		I	The +1.8V pins provide power for the internal core logic.
	VSS		I	These pins form the ground connections for all of the input macros, output macros, and core logic.
	PLL_VDD		I	The +1.8V pin provides clean power to the internal Analog Phase Locked Loop.
	PLL_VSS		I	This input provides clean ground to the internal Analog Phase Locked Loop.

8.5 Pinout

Tsi148's pinout is illustrated in the [Figure 34](#) Use this diagram along with the tables in the following sections to locate pin assignments on the Tsi148:

- [Table 17 on page 172](#) lists the pinout according to pin assignment
- [Table 18 on page 179](#) lists ground pins according to pin assignment
- [Table 19 on page 182](#) lists core power pins according to pin assignment
- [Table 20 on page 183](#) lists I/O power pins according to pin assignment

Figure 34: Pinout — Bottom View

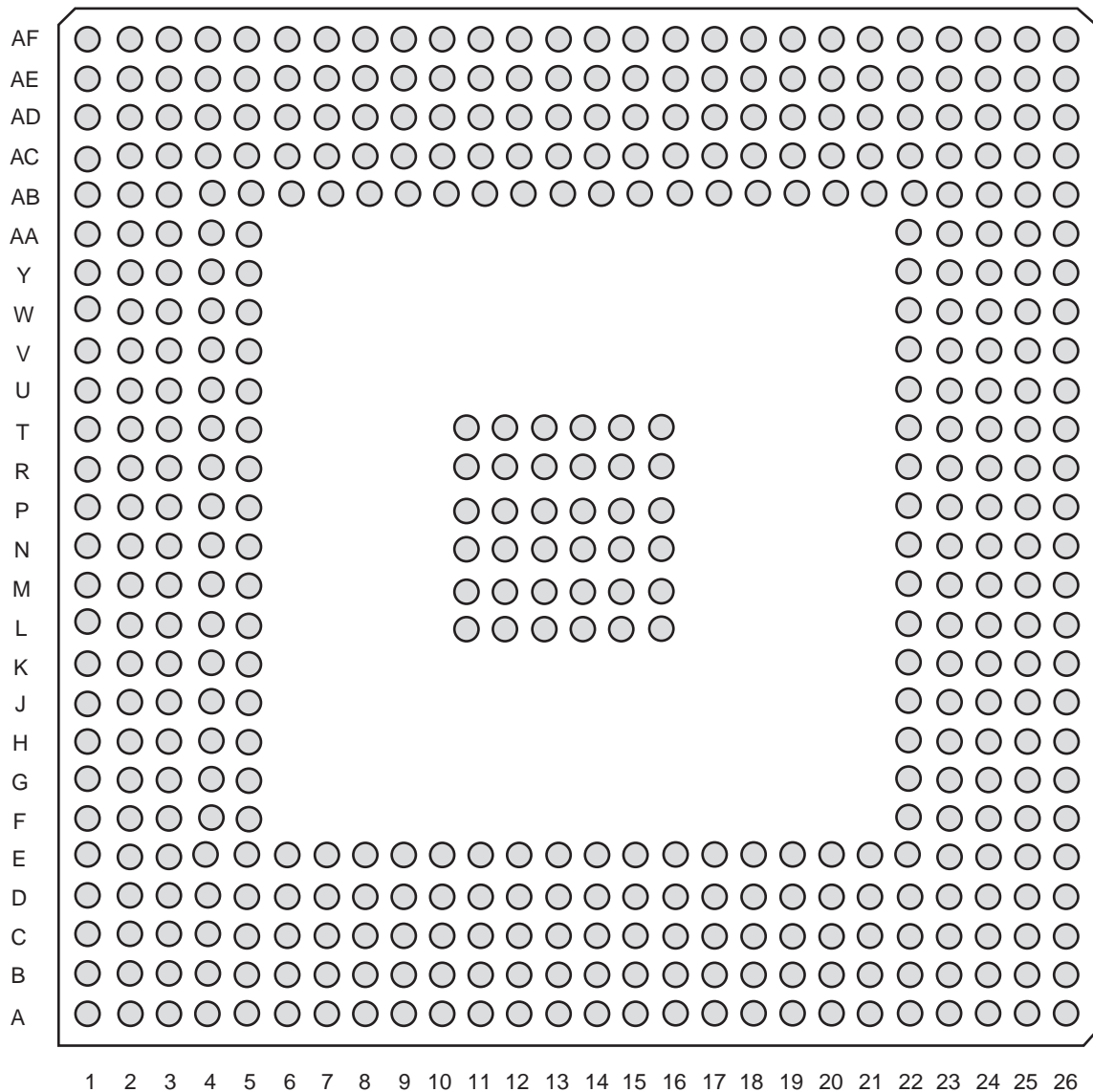

8.5.1 Sorted by Pin Assignment

The following table lists Tsi148's pinout in numerical order according to pin assignment. Use this table along with [Figure 34 on page 171](#) to locate Tsi148 signal names or pin assignments.

Table 17: Pinout — Sorted by Pin Assignment

Pin Assignment	Signal Name
A03	PLL_TUNE7
A04	VD1
A05	PLL_TUNE4
A07	PLL_VDDA
A08	VD8
A09	PLL_GNDA
A10	VD12
A12	VD20
A13	VD21
A14	VD24
A15	VD25
A17	BBSYI_
A18	BG0OUT_
A19	BG1INOUT_
A20	BG2IN_
A22	BR1O
A23	BR2I_
A24	BERRO_
A25	ADBOU
B01	SCON
B03	PLL_TUNE9
B04	PLL_TUNE6
B05	PLL_TEN
B06	VD2
B07	VD3
B08	PLL_TUNE3
B09	VD7
B10	VD10
B11	VD11
B12	VD15
B13	VD19
B14	VD26
B15	VD30
B16	BCLRO_
B17	BG0IN_

Table 17: Pinout — Sorted by Pin Assignment (Continued)

Pin Assignment	Signal Name
B18	BG1IN_
B19	BG3OUT_
B20	BR00
B21	BR20
B22	BR3I_
B23	BERROE
B24	AMOUT
C01	TDI
C02	SCONDIS_
C04	PLL_TUNE8
C05	PLL_OUTA
C06	PLL_TUNE5
C07	VD4
C08	PLL_TUNE2
C09	VD9
C10	PLL_TUNE0
C11	VD14
C12	VD17
C13	VD23
C14	VD22
C15	VD27
C16	VD31
C17	BCLRI_
C18	BG1OUT_
C19	BG2INOUT_
C20	BG3IN_
C21	BR1I_
C22	BERRI_
C23	DBOE_
C25	DTACKOE
C26	DSEO
D01	TRST_
D02	TCK
D03	NO CONNECT
D05	PLL_RSTI_
D06	VD0
D07	PCLK
D08	VD5

Table 17: Pinout — Sorted by Pin Assignment (Continued)

Pin Assignment	Signal Name
D09	VD6
D10	PLL_TUNE1
D11	VD13
D12	VD18
D13	VD16
D14	VD29
D15	VD28
D16	BBSYO
D17	BG0INOUT_
D18	BG2OUT_
D19	BG3INOUT_
D20	BR0I_
D21	BR3O
D22	DBOUT
D24	DTACKO_
D25	DS0O_
D26	DS1I_
E01	INTB_
E02	TMS
E03	SCONEN_
E23	DTACKI_
E24	SYSCLK
E25	DS0I_
E26	IACKOUT_
F02	TDO
F03	INTA_
F23	DS1O_
F24	ASO_
F25	ASOE
G01	AD62
G02	INTC_
G03	INTD_
G23	ASI_
G24	RETRYOE
G25	IACKIN_
G26	IACK_
H01	AD59
H02	AD63

Table 17: Pinout — Sorted by Pin Assignment (Continued)

Pin Assignment	Signal Name
H03	AD61
H23	RETRYO_
H24	AM0
H25	RETRYI_
H26	AM3
J01	AD57
J02	AD60
J03	AD58
J23	AM1
J24	AM4
J25	AM2
J26	LWORD_
K01	AD54
K02	NO CONNECT
K03	AD56
K23	WRITE_
K24	VA1
K25	AM5
K26	VA3
L02	AD55
L03	AD53
L23	VA4
L24	VA5
L25	VA2
M01	NO CONNECT
M02	AD52
M03	AD51
M23	VA9
M24	VA8
M25	VA6
M26	VA11
N01	AD49
N02	AD50
N03	AD47
N23	VA7
N24	VA14
N25	VA10
N26	VA12

Table 17: Pinout — Sorted by Pin Assignment (Continued)

Pin Assignment	Signal Name
P01	AD46
P02	AD44
P03	AD48
P23	VA20
P24	VA13
P25	VA17
P26	VA15
R01	AD45
R02	AD42
R03	AD43
R23	VA19
R24	VA18
R25	VA21
R26	VA16
T02	AD40
T03	AD41
T23	VA23
T24	VA22
T25	VA25
U01	NO CONNECT
U02	AD37
U03	AD39
U23	VA28
U24	VA26
U25	VA29
U26	VA24
V01	AD38
V02	AD34
V03	AD36
V23	ACFAILI_
V24	VA30
V25	NO CONNECT
V26	VA27
W01	AD35
W02	PAR64
W03	AD33
W23	LRSTI_
W24	PURSTI_

Table 17: Pinout — Sorted by Pin Assignment (Continued)

Pin Assignment	Signal Name
W25	LRSTO_
W26	VA31
Y01	AD32
Y02	CBE6_
Y03	CBE7_
Y23	SFAILO
Y24	BDFAIL_
Y25	SRSTO
Y26	LSRSTI_
AA02	ACK64_
AA03	CBE4_
AA23	IRQ2O
AA24	SFAILI_
AA25	IRQ1I_
AB01	CBE5_
AB02	PERR_
AB03	GNT_
AB23	TM_IN
AB24	IRQ3I_
AB25	PCIMC
AB26	SRSTI_
AC01	REQ64_
AC02	SERR_
AC03	PCIPUEN
AC24	IRQ4O
AC25	IRQ2I_
AC26	IRQ1O
AD01	M66EN
AD02	REQ_
AD04	HWC_PFU
AD05	IRDY_
AD06	CBE1_
AD07	AD31
AD08	AD28
AD09	AD25
AD10	AD23
AD11	AD20
AD12	AD18

Table 17: Pinout — Sorted by Pin Assignment (Continued)

Pin Assignment	Signal Name
AD13	AD14
AD14	AD15
AD15	AD10
AD16	AD8
AD17	AD6
AD18	AD3
AD19	AD0
AD20	GA2_
AD21	GAP_
AD22	IRQ50
AD23	IRQ51_
AD25	IRQ41_
AD26	IRQ30
AE03	FRAME_
AE04	STOP_
AE05	IDSEL
AE06	CBE2_
AE07	PAR
AE08	AD30
AE09	AD27
AE10	NO CONNECT
AE11	AD22
AE12	AD19
AE13	AD17
AE14	AD11
AE15	AD9
AE16	AD7
AE17	AD4
AE18	AD1
AE19	GA3_
AE20	GA1_
AE21	IRQ71_
AE22	CE0_TEST
AE23	IRQ61_
AE24	NO CONNECT
AE26	TM_OUT
AF02	DEVSEL_
AF03	TRDY_

Table 17: Pinout — Sorted by Pin Assignment (Continued)

Pin Assignment	Signal Name
AF04	CBE3_
AF05	CBE0_
AF07	AD29
AF08	AD26
AF09	AD24
AF10	AD21
AF12	NO CONNECT
AF13	AD16
AF14	AD13
AF15	AD12
AF17	NO CONNECT
AF18	AD5
AF19	AD2
AF20	GA4_
AF22	GA0_
AF23	IRQ7O
AF24	IRQ6O

8.5.1.1 Ground Pins

The following table lists Tsi148's ground pins in numerical order according to pin assignment. Use this table along with [Figure 34 on page 171](#) to locate Tsi148 signal names or pin assignments.

Table 18: VSS (Ground) — Sorted by Pin Assignment

Pin Assignment	Signal Name
A01	VSS
A02	VSS
A06	VSS
A11	VSS
A16	VSS
A21	VSS
A26	VSS
B02	VSS
B25	VSS
B26	VSS
C03	VSS
C24	VSS
D04	VSS

Table 18: VSS (Ground) — Sorted by Pin Assignment (Continued)

Pin Assignment	Signal Name
D23	VSS
E09	VSS
E14	VSS
E18	VSS
F01	VSS
F26	VSS
J05	VSS
J22	VSS
L01	VSS
L11	VSS
L13	VSS
L14	VSS
L16	VSS
L26	VSS
M12	VSS
M13	VSS
M15	VSS
N05	VSS
N11	VSS
N13	VSS
N14	VSS
N15	VSS
N16	VSS
P11	VSS
P12	VSS
P13	VSS
P14	VSS
P16	VSS
P22	VSS
R12	VSS
R14	VSS
R15	VSS
T01	VSS
T11	VSS
T13	VSS
T14	VSS
T16	VSS
T26	VSS

Table 18: VSS (Ground) — Sorted by Pin Assignment (*Continued*)

Pin Assignment	Signal Name
V05	VSS
V22	VSS
AA01	VSS
AA26	VSS
AB09	VSS
AB13	VSS
AB18	VSS
AC04	VSS
AC23	VSS
AD03	VSS
AD24	VSS
AE01	VSS
AE02	VSS
AE25	VSS
AF01	VSS
AF06	VSS
AF11	VSS
AF16	VSS
AF21	VSS
AF25	VSS
AF26	VSS

8.5.1.2 Power Pins

The following tables lists Tsi148's core and I/O power pins in numerical order according to pin assignment. Use this table along with [Figure 34 on page 171](#) to locate Tsi148 signal names or pin assignments.

Table 19: Core Power (1.8 V) — Sorted by Pin Assignment

Pin Assignment	Signal Name
E05	VDD
E10	VDD
E11	VDD
E12	VDD
E15	VDD
E16	VDD
E17	VDD
E22	VDD
K05	VDD
K22	VDD
L05	VDD
L22	VDD
M05	VDD
M14	VDD
M22	VDD
N12	VDD
P15	VDD
R05	VDD
R13	VDD
R22	VDD
T05	VDD
T22	VDD
U05	VDD
U22	VDD
AB05	VDD
AB10	VDD
AB11	VDD
AB12	VDD
AB15	VDD
AB16	VDD
AB17	VDD
AB22	VDD

Table 20 shows Tsi148's I/O power pins in numerical order according to pin assignment. Use this table along with Figure 34 on page 171 to locate Tsi148 signal names or pin assignments.

Table 20: I/O Power (3.3 V) — Sorted by Pin Assignment

Pin Assignment	Signal Name
E04	VDD2
E06	VDD2
E07	VDD2
E08	VDD2
E13	VDD2
E19	VDD2
E20	VDD2
E21	VDD2
F04	VDD2
F05	VDD2
F22	VDD2
G04	VDD2
G05	VDD2
G22	VDD2
H04	VDD2
H05	VDD2
H22	VDD2
J04	VDD2
K04	VDD2
L04	VDD2
L12	VDD2
L15	VDD2
M04	VDD2
M11	VDD2
M16	VDD2
N04	VDD2
N22	VDD2
P04	VDD2
P05	VDD2
R04	VDD2
R11	VDD2
R16	VDD2
T04	VDD2
T12	VDD2
T15	VDD2
U04	VDD2

Table 20: I/O Power (3.3 V) — Sorted by Pin Assignment (*Continued*)

Pin Assignment	Signal Name
V04	VDD2
W04	VDD2
W05	VDD2
W22	VDD2
Y04	VDD2
Y05	VDD2
Y22	VDD2
AA04	VDD2
AA05	VDD2
AA22	VDD2
AB14	VDD2
AB19	VDD2
AB20	VDD2
AB21	VDD2
AB04	VDD2
AB06	VDD2
AB07	VDD2
AB08	VDD2
AC05	VDD2
AC06	VDD2
AC07	VDD2
AC08	VDD2
AC09	VDD2
AC10	VDD2
AC11	VDD2
AC12	VDD2
AC13	VDD2
AC14	VDD2
AC15	VDD2
AC16	VDD2
AC17	VDD2
AC18	VDD2
AC19	VDD2
AC20	VDD2
AC21	VDD2
AC22	VDD2

9. Electrical Characteristics

The electrical characteristics of a device depend on its design and intended application. Device signals that are protocol-compliant must conform with a set of electrical operating characteristics for that protocol. DC electrical characteristics for a device define parameters such as supply, input, and output voltages. AC characteristics specify the input requirements (for example, setup and hold times) and output responses (that is, delays from clock to signal) and are normally defined for each clock domain for a device. Absolute maximum ratings, if available, define the maximum operating conditions such as supply voltage, power, and operating temperature.

This chapter discusses the following topics about Tsi148's electrical characteristics:

- [“Operating Conditions” on page 188](#)
- [“Power Consumption” on page 189](#)
- [“Thermal Characteristics” on page 190](#)
- [“Electrostatic Discharge \(ESD\)” on page 192](#)

9.1 Overview of Electrical Characteristics

Tsi148's electrical characteristics are defined by PCI/X electrical characteristics and non-PCI/X electrical characteristics.

9.1.1 PCI/X Electrical Characteristics

The Tsi148's PCI/X interface is electrically compatible with the 3.3V signaling interface as defined by the PCI-X Addendum to *PCI-X Addendum to PCI Local Bus Specification (Revision 1.0b)* and the *PCI Local Bus Specification (Revision 2.2)*.

Table 21 specifies DC characteristics of all Tsi148's PCI/X signal pins.

Table 21: PCI/X Electrical Characteristics

Symbol	Parameter	Condition	PCI-X		3.3V Conventional PCI		Units
			Min	Max	Min	Max	V
V_{DD}	Supply voltage		3.0V	3.6V	3.0V	3.6V	V
V_{IH}	Input high voltage		$0.5 \cdot V_{DD}$	$V_{DD} + 0.5$	$0.5 \cdot V_{DD}$	$V_{DD} + 0.5$	V
V_{IL}	Input low voltage		-0.5	$0.35 \cdot V_{DD}$	-0.5	$0.3 \cdot V_{DD}$	V
V_{IPU}	Input pull-up voltage		$0.7 \cdot V_{DD}$		$0.7 \cdot V_{DD}$		V
V_{OH}	Output high voltage	$I_{OUT} = -500\mu A$	$0.9 \cdot V_{DD}$		$0.9 \cdot V_{DD}$		V
V_{OL}	Output low voltage	$I_{OUT} = 1500\mu A$		$0.1 \cdot V_{DD}$		$0.1 \cdot V_{DD}$	V
C_{IN}	Input pin capacitance			8		10	pF

9.1.2 Non-PCI Electrical Characteristics

The following tables detail the DC characteristics of all non-PCI/X Tsi148 signal pins.

Table 22: 3.3 V LVTTTL DC Electrical Characteristics

Symbol	Parameter	Condition	Min	Max	Units
V_{IL}	Input low voltage	-	0.0	0.8	V
V_{IH}	Input high voltage	-	2.0	VDD2	V

Table 23: 5.0 V LVTTTL DC Electrical Characteristics

Symbol	Parameter	Condition	Min	Max	Units
V_{IL}	Input low voltage	-	0.0	0.8	V
V_{IH}	Input high voltage	-	2.0	5.5	V

Table 24: Common Receiver DC Electrical Characteristics

Symbol	Parameter	Condition	Min	Max	Units
I_{IN}	Input leakage Current	-		0	μ A
I_{IN}	Input leakage Current (pull-up)	$V = 0V$		-150	μ A
I_{IN}	Input leakage Current (pull-down)	$V = VDD\ IO\ Max$		200	μ A

Table 25: LVTTTL Driver DC Electrical Characteristics

Symbol	Parameter	Condition	Min	Max	Units
V_{OH}^a	Output high voltage	$I_{OH} = -15.3\ mA$ (35 ohm output)	2.4		V
V_{OL}^a	Output low voltage	$I_{OL} = 10.2\ mA$ (35 ohm output)		0.4	V
V_{OH}^a	Output high voltage	$I_{OH} = -8.2\ mA$ (65 ohm output)	2.4		V
V_{OL}^a	Output low voltage	$I_{OL} = 5.4\ mA$ (65 ohm output)		0.4	V

a. VDD is 1.65V and the temperature is 100°C

Table 26: 1.8 V CMOS Driver DC Electrical Characteristics

Symbol	Parameter	Condition	Min	Max	Units
V_{OH}	Output high voltage	$I_{OH} = -6.1 \text{ mA}$ (65 ohm output)	1.2		V
V_{OL}	Output low voltage	$I_{OL} = 6.0 \text{ mA}$ (65 ohm output)		0.45	V

9.2 Operating Conditions

9.2.1 Absolute Maximum Operating Conditions

Stresses above those listed may cause permanent damage to the device. This is a stress rating only and functional operation of the device at these or any other conditions above those indicated in the operation sections of this specification is not implied. Exposure to absolute maximum rating conditions for extended periods may affect device reliability.

Table 27: Absolute Maximum Ratings

Symbol	Parameter	Min	Max	Unit
V_{DD}	1.8V DC Supply Voltage	-0.3	2.0	V
V_{DD2}	3.3V DC Supply Voltage	-0.3	3.6	V
V_{IN}	LVTTL Input Voltage	-0.6	$V_{DD33} + 0.3$	V
V_{IN}	5V-Tolerant Input Voltage	-0.6	+5.5	V
I_{IN}	DC Input Current	-10	+10	μA
T_{STG}	Storage Temperature Range	-65	+150	$^{\circ}\text{C}$

9.2.2 Recommended Operating Conditions

This device contains circuitry to protect the inputs against damage due to high static voltages or electric fields; however, it is advised that normal precautions be taken to avoid application of any voltage higher than maximum rated voltages to this high impedance circuit. Unused inputs must always be tied to an appropriate logic voltage level.

Table 28: Recommended Operating Conditions

Symbol	Parameter	Min	Max	Unit
V _{DD}	1.8V DC Supply Voltage	+1.65	+1.95	V
V _{DD2}	3.3V DC Supply Voltage	+3.0	+3.6	V
PLL_VDD	PLL 1.8V Analog Supply	1.65	1.95	V
T _A	Operating Ambient Temperature Range (Commercial)	0	+70	°C
T _A	Operating Ambient Temperature Range (Industrial)	-40	+85	°C
T _j	Junction Temperature		+122	°C

9.2.3 Power Supply Sequencing

The Tsi148 uses the 1.8V supply to power its core logic and the 3.3V supply to power its I/O buffers. If the 3.3V is supplied before the 1.8V, the Tsi148 I/O buffers are in an undefined state, and possibly driving, until the core 1.8V is applied. It is recommended to supply the 1.8V before, or concurrently, with the 3.3V supply.

If the board design requires the 3.3V be supplied before the 1.8V supply, contact Tundra's Applications Engineering team.

9.3 Power Consumption

Table 29 shows the power dissipation for Tsi148 using different frequency parameters and bus loading.

Table 29: Tsi148 Total Power Dissipation (Core + IO)

PCI/X Clock Frequency (MHz)	PCI/X Load (pF)	Minimum (W)	Nominal (W)	Maximum (W)
133	10	1.19	1.41	1.64
100	20	1.24	1.46	1.71
66	40	1.34	1.58	1.84

Table 30 shows how the power dissipation is divided in the Tsi148. The IO portion can be determined by subtracting the Total Core Logic Power from the Total Power Dissipation.

Table 30: Tsi148 Power Dissipation Division

Source	Nominal (W)
Total Core Logic Power	1.322
PLL Power	0.030

9.4 Thermal Characteristics

Based on the worst case die power dissipation of 1.84W the Tsi148's thermal performance does meet the industrial grade requirements. These results are based on the Tsi148 being routed on an 8 layer PCB. It should be noted that the thermal simulations for a JEDEC standard 4 layer PCB with a worst case power dissipation of 1.84W, the Tsi148 does not have sufficient thermal performance to meet the industrial grade requirements. If the worst case die power dissipation is less than or equal to 1.7W, the Tsi148 does have sufficient thermal performance to meet the industrial grade requirements when routed on a 4 layer PCB.

The maximum ambient temperature of the Tsi148 can be calculated as follows:

$$T_a \leq T_j - \theta_{ja} * P$$

Where,

T_a = Ambient temperature (°C)

T_j = Maximum Tsi148 Junction temperature (°C) = 122°C

θ_{ja} = Ambient to Junction Thermal Impedance (°C/Watt)

P = Tsi148 power consumption (Watts) (“**Power Consumption**” on page 189).

9.4.1 Junction-to-Ambient Thermal Characteristics (θ_{ja})

The junction-to-ambient thermal impedance (θ_{ja}) is dependent on the air flow in meters per second over the Tsi148.

Table 31 and **Table 32** show the package thermal performance for the Tsi148 device according to the number of layers on the PCB.

Table 31: 456 EPBGA Package Thermal Performance for an 8 layer PCB

Air Flow (m/s)	Power Consumption (W)	Theta ja (°C/W)
0	1.84	19
1	1.84	16.1
2	1.84	15.1

Table 32: 456 EPBGA Package Thermal Performance for a 4 layer PCB

Air Flow (m/s)	Power Consumption (W)	Theta ja (°C/W)
0	1.84	21.5
1	1.84	18.0
2	1.84	16.8

9.4.2 Junction-to-Board and Junction-to-Case Characteristics

Table 33 shows the simulated Theta jb and Theta jc thermal characteristics of the Tsi148 package.

Table 33: Thermal Characteristics of Tsi148

Interface	Result
Theta jb (junction-to-board)	16.6 °C/watt
Theta jc (junction-to-case)	10.3 °C/watt

9.5 Electrostatic Discharge (ESD)

The Tsi148 is a Charge Device Model test (CDM) Class II device as classified in the *JEDEC JESD22-C101-A Specification*. **Table 34** shows the varying ESD tests and JEDEC classifications for the Tsi148 device.

Table 34: Tsi148 ESD Classification

ESD Test	Protection Value	JEDEC Rating	JEDEC Specification
Human Body Model (HBM)	2000V	Class 2	JESD22-A114-B
Machine Model (MM)	200V	Class B	JESD22-A115-A
Charge Device Model (CDM)	200V	Class II	JESD22-C101-A

The Tsi148 has passed a CDM of 200V protection, but failed 500V protection. This rates the Tsi148 as JEDEC Class II (200V to <500V). The exact threshold voltage has not yet been determined but is between 200V and 500V. The most sensitive CDM Tsi148 pins are PLL_VDD, PLL_VSS, PLL_OUTA, and CEO_TEST.

All other pins meet CDM Class III (500V to <1000V).

9.5.1 ESD Precautions

Precautions must be taken to reduce ESD exposure. The following practices are recommended to help reduce ESD exposure:

- Wear wrist straps while seated
- Wear footwear or heel straps while standing
- Wear ESD smocks
- Regularly check wrist straps and footwear
- Ensure ESD dissipative flooring and work surfaces
- Ensure work surfaces and equipment connected to electrical ground
- Use ESD compliant chairs and carts, or “drag-chain” to the floor
- Maintain humidity between 30% and 70% in all inspection and assembly areas
- Minimize inspection and handling. If inspection is required, keep parts within trays (if possible)

- Ensure conductive and electrostatic generating materials are not in close proximity to the Tsi148 when unprotected. For example, shop travelers, labels, cardboard, Plexiglas, wood, CRT screens, etc.
- Use ionization systems to help dissipate residual charge built up on any material that is static generating and is in close proximity to the Tsi148
- Use a field strength meter to check items that come into contact with the Tsi148. The field strength meter tool is useful in confirming safe surfaces and those that contain residual charges needing neutralizing ionizers.

10. Registers

This appendix describes the Tsi148's registers. The following topics are discussed:

- “Overview of Registers” on page 196
 - “Register Groupings” on page 196
 - “Register Endian Mapping” on page 199
 - “Register Map” on page 201
-

10.1 Overview of Registers

This chapter provides a detailed description of the Tsi148's internal registers. These registers are separated into four groups: the PCI/X Configuration Space registers (PCFS), the Local Control and Status Registers (LCSR), the VMEbus Global Control and Status Registers (GCSR) and the VMEbus Configuration ROM / Control and Status Registers (CR/CSR).

Registers can be accessed by the Tsi148 PCI/X Target or the VME Slave through the internal Linkage Module.

10.2 Register Groupings

Tsi148 register space is separated into different groups within Tsi148. [Figure 35](#) shows the complete register map and individual groups.

Figure 35: Combined Register Group (CRG)

4 Kbyte CRG	1024 bytes	CSR
	1504 bytes	Reserved
	32 bytes	GCSR
	1280 bytes	LCSR
	256 bytes	PCFS

10.2.1 Combined Register Group (CRG)

The CRG requires 4 Kbytes of address space. The address space can be mapped into PCI/X address space using the standard PCI/X BAR (located at offsets 0x10h and 0x14h). All CRG accesses through the PCI/X BAR pass through the PCI/X Target Interface.

The CRG can also be mapped into A16, A24, A32 and A64 VME address space through the CRG image (located at offsets 0x40Ch – 0x414h). The CRG can be accessed using D8, D16 and D32 SCT transactions. All accesses pass through the VME Slave Interface.

Alternatively, the CRG can be accessed as part of the 512 Kbyte CR/CSR area defined in the *American National Standard for VME64* by using the special A24 CR/CSR AM code.

10.2.2 PCI/X Configuration Space Registers (PCFS)

This register area is the standard PCI/X configuration space and is accessible from the PCI/X bus using PCI/X configuration cycles.

The PCFS area includes a standard 64-bit Base Address Register (see MBARL and MBARU registers in [Section 10.4.2 on page 202](#)) which enables the CRG to be mapped into PCI/X memory space.

The PCFS can also be accessed from the VMEbus as part of the CRG group.

10.2.3 Local Control and Status Registers (LCSR)

The LCSR register group contains the inbound and outbound map decoder registers, DMA, interrupt control registers, and other miscellaneous registers. It can be accessed from either the PCI/X bus or VMEbus as part of the CRG.

10.2.4 Global Control and Status Registers (GCSR)

The GCSR register group contains control bits, semaphore, and mailbox registers which allow information to be passed between processors on other VMEbus boards and the local processor.

It can be accessed from either the PCI/X bus or VMEbus as part of the CRG. Alternatively, the GCSR group can be independently accessed from the VMEbus by using the GCSR image (located at offsets 0x418h – 0x420h).

The GCSR can be mapped to the VMEbus A16, A24, A32 or A64 address spaces and accepts D8, D16 and D32 SCT transactions.

10.2.5 Control and Status Registers (CSR)

The CSR register group is a sub-set of the CR/CSR section of the CR/CSR registers defined in the *American National Standard for VME64 Extensions*. Tsi148 implementation of these standard registers include: the CR/CSR Bit Clear, CR/CSR Bit Set, and CR/CSR Base Address Registers.

10.2.6 CR/CSR Register Access

The 512 Kbyte CR/CSR space, shown in [Figure 36](#), can be accessed from the VMEbus using the special A24 CR/CSR AM code.

The Base Address is defined by either Geographical Address Implementation or Auto Slot ID. Tsi148's VME Slave can be configured at power-up to use one of the two methods (see [Section 5.4 on page 128](#)). When an access is initiated on the VMEbus using the A24 CR/CSR AM code, the Tsi148 initiates an access on the PCI/X bus when the enable bit in the CR/CSR Attribute Register is set (located at offset 0x420). The address generated on the PCI/X bus is determined by the values in the CR/CSR Offset registers (located at offsets 0x418 and 0x41C). These values are added to the internal VMEbus address to create the PCI/X bus address.

The address space is separated into the following areas:

- The upper 4 Kbytes defines the Tsi148 CRG
- The remaining 508 Kbytes maps to the PCI/X bus.
 - When an access is initiated on the VMEbus using A24 CR/CSR AM code, Tsi148 initiates an access on the PCI/X bus when the CR/CSR offset register is enabled.

Figure 36: CR/CSR Address Space

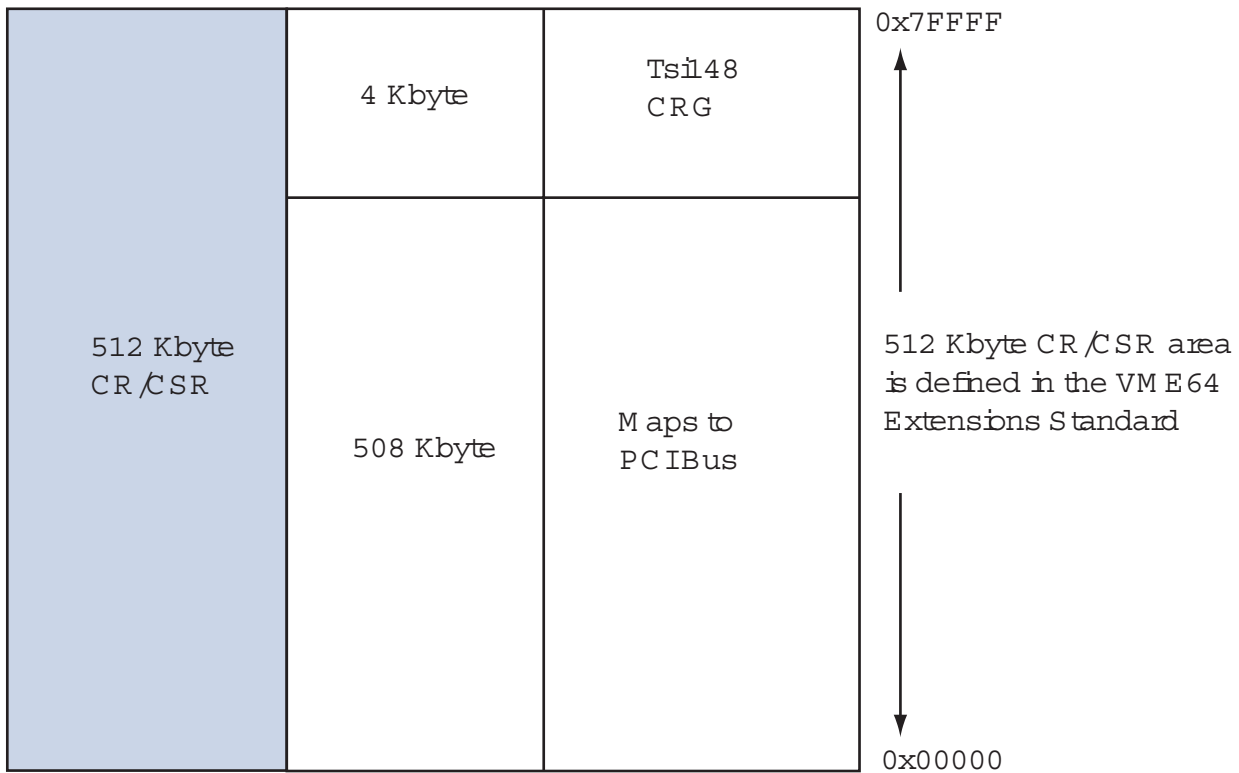

10.3 Register Endian Mapping

The VMEbus uses Big-Endian byte ordering and the PCI/X bus uses Little-Endian byte ordering. The byte ordering differences are accommodated by swapping the data in the PCI/X Master and PCI/X Target before it is passed to the Linkage Module. Data transferred between the PCI/X bus and the Linkage Module is swapped as shown in [Figure 37](#). This method of handling the endian problem is called *address invariance*. If data is accessed using byte operations, *little endian* and *big endian* processors view the same data. If data is accessed using 32-bit accesses, *little endian* and *big endian* processors see different views of the same data.

Figure 37: Big to Little Endian Data Swap

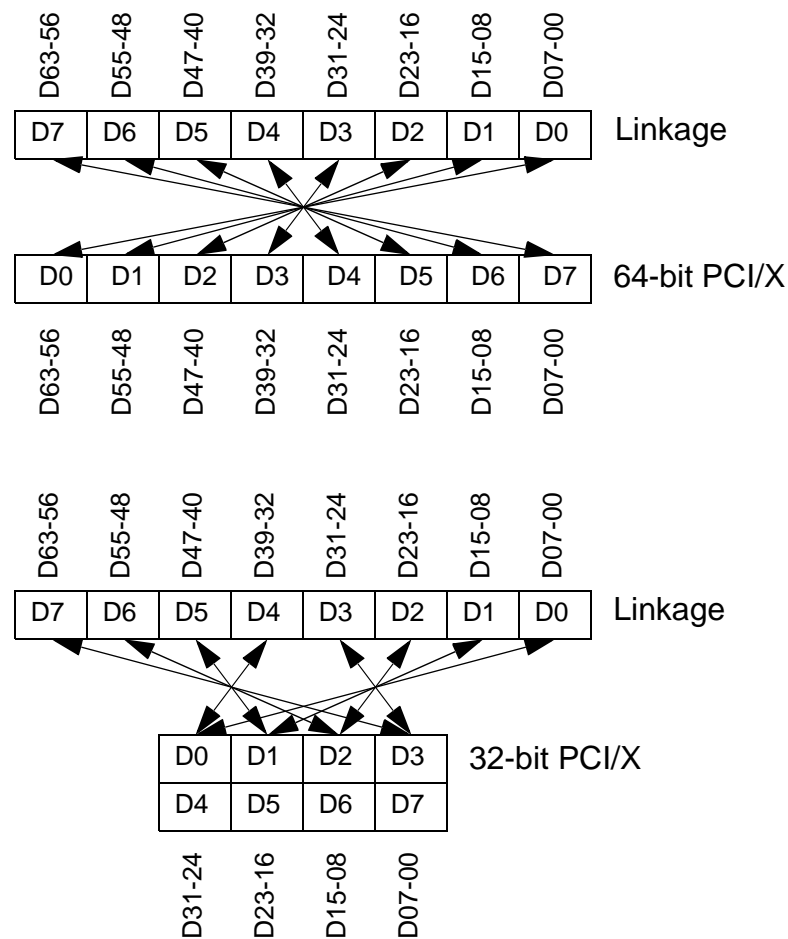

When viewed from the VMEbus, the LCSR, GCSR and CR/CSR registers appear as presented in the programming section. When viewed from the VMEbus, the PCFS registers appear swapped.

When viewed from the PCI/X bus, the LCSR, GCSR and CR/CSR registers appear swapped. When viewed from the PCI/X bus, the PCFS registers appear as presented in the programming section.

Table 35 summarizes the register views. This table assumes the processor is operating in big endian mode and that the bridge between the processor bus and PCI/X bus swaps the data. This table assumes the 32-bit value ABCD is stored in a register and that the data is accessed using a 32-bit read.

Table 35: Endian Register Views

Register Group	Value in Register	Value on PCI/X bus	Value on Processor bus	Value on VMEbus
PCFS	ABCD	ABCD	DCBA	DCBA
LCSR	ABCD	DCBA	ABCD	ABCD
GCSR	ABCD	DCBA	ABCD	ABCD
CR/CSR	ABCD	DCBA	ABCD	ABCD

Data transferred between the VMEbus and the PCI/X bus is swapped. When a processor operating in big endian mode transfers data from the VMEbus, the data is swapped in the VME bridge and swapped again in the host bridge. The two swaps effectively cancel each other and processor sees the VMEbus data in the correct order. When a processor operating in little endian mode is used, the VMEbus data appears swapped.

10.4 Register Map

The register map shows all the Tsi148 register groupings in the Combined Register Group (CRG). The CRG requires 4 Kbytes of address space. The address space can be mapped into PCI/X address space or VMEbus address space. Refer to [Section 10.2.1 on page 196](#) for more information on the CRG and all the group that comprise the Tsi148 registers.

10.4.1 Conventions

The following conventions are used to describe the operation of a register bit and are found in the “Type” column of the register description table:

- R: Read Only field
- R/W: Read/Write field.
- S: Writing a 1 to this field sets this field.
- C: Writing a 1 to this field clears an associated field.
- R/S: Writing a 1 to this field sets an associated field. Reading this field returns the current value of the associated field.
- R/C: Writing a 1 to this field clears an associated field. Reading this field returns the current value of the associated field

The following conventions are used to describe the effect of the reset signals on a register bit and are found in the “Reset By” heading of the register description table:

- L: The field is affected by PCI/X local bus reset.
- S: The field is affected by VMEbus system reset.
- P: The field is affected by power up reset.
- *x*: The reset value depends on configuration options.

Bits that are reset by multiple signals show the signals with a slash (/) separating them. For example, if a bit is reset by all the reset signals, the register table shows the following value: L/S/P/X.

10.4.2 PCFS Register Group Overview

This register area is the standard PCI/X configuration space and is accessible from the PCI/X bus using PCI/X configuration cycles. Refer to [Section 10.2.2 on page 197](#) for more information on the PCFS registers.

Table 36: PCFS Register Group

Function		Bits												Offset PCFS/ CRG
		31		24	23		16	15		8	7		0	
PCI/X Configuration	Header	Device ID (DEVI)						Vendor ID (VENI)						0x00/ 0x000
		STATUS (STAT)						Command (CMMD)						0x04/ 0x004
		Class Code (CLAS)								Revision ID (REVI)				0x08/ 0x008
		Reserved			Header Type (HEAD)			Master Latency Timer (MLAT)			Cache Line Size (CLSZ)			0x0C/ 0x00C
		Memory Base Address Lower (MBARL)												0x10/ 0x010
		Memory Base Address Upper (MBARU)												0x14/ 0x014
		Reserved												0x18/ 0x018
		Reserved												0x1C/ 0x01C
		Reserved												0x20/ 0x020
		Reserved												0x24/ 0x024

Table 36: PCFS Register Group

Function		Bits											Offset PCFS/ CRG
		31		24	23		16	15		8	7		
PCI/X Configuration	Header	Reserved											0x28/ 0x028
		Subsystem ID (SUBI)					Subsystem Vendor ID (SUBV)						0x2C/ 0x02C
		Reserved											0x30/ 0x030
		Reserved							Capabilities Pointer (CAPP)				0x34/ 0x034
		Reserved											0x38/ 0x038
		Maximum Latency (MXLA)			Minimum Grant (MNGN)			Interrupt Pln (INTP)		Interrupt Line (INTL)			0x3C/ 0x03C
	PCI-X Capabilities	PCI-X Capabilities (PCIXCAP)											0x40/ 0x040
		PCI-X Status (PCIXSTAT)											0x44/ 0x044
		Reserved	Reserved										
	Reserved											-	
	Reserved											0xFF/ 0x0FF	

10.4.3 LCSR Register Group Overview

The LCSR register group contains the inbound and outbound slave image registers, DMA, interrupt control registers, and other miscellaneous registers. It can be accessed from either the PCI/X bus or VMEbus as part of the CRG.

Table 37: LCSR Register Group

Function		Bits											Offset CRG
		31		24	23		16	15		8	7		
Outbound Functions	Outbound Translation 0	Outbound Translation Starting Address Upper 0 (OTSAU0)											0x100
		Outbound Translation Starting Address Lower 0 (OTSAL0)											0x104
		Outbound Translation Ending Address Upper 0 (OTEAU0)											0x108
		Outbound Translation Ending Address Lower 0 (OTEAL0)											0x10C
		Outbound Translation Offset Upper 0 (OTOFU0)											0x110
		Outbound Translation Offset Lower 0 (OTOFLO)											0x114
		Outbound Translation 2eSST Broadcast Select 0 (OTBS0)											0x118
		Outbound Translation Attribute 0 (OTAT0)											0x11C

Table 37: LCSR Register Group

Function		Bits											Offset CRG
		31		24	23		16	15		8	7		
Outbound Functions	Outbound Translation 1	OTSAU1											0x120
		OTSAL1											0x124
		OTEAU1											0x128
		OTEAL1											0x12C
		OTOFU1											0x130
		OTOFL1											0x134
		OTBS1											0x138
		OTAT1											0x13C
	Outbound Translation 2	OTSAU2											0x140
		OTSAL2											0x144
		OTEAU2											0x148
		OTEAL2											0x14C
		OTOFU2											0x150
		OTOFL2											0x154
		OTBS2											0x158
		OTAT2											0x15C
	Outbound Translation 3	OTSAU3											0x160
		OTSAL3											0x164
		OTEAU3											0x168
		OTEAL3											0x16C
		OTOFU3											0x170
		OTOFL3											0x174
		OTBS3											0x178
		OTAT3											0x17C

Table 37: LCSR Register Group

Function		Bits												Offset CRG
		31		24	23		16	15		8	7		0	
Outbound Functions	Outbound Translation 4	OTSAU4												0x180
		OTSAL4												0x184
		OTEAU4												0x188
		OTEAL4												0x18C
		OTOFU4												0x190
		OTOFL4												0x194
		OTBS4												0x198
		OTAT4												0x19C
	Outbound Translation 5	OTSAU5												0x1A0
		OTSAL5												0x1A4
		OTEAU5												0x1A8
		OTEAL5												0x1AC
		OTOFU5												0x1B0
		OTOFL5												0x1B4
		OTBS5												0x1B8
		OTAT5												0x1BC
	Outbound Translation 6	OTSAU6												0x1C0
		OTSAL6												0x1C4
		OTEAU6												0x1C8
		OTEAL6												0x1CC
		OTOFU6												0x1D0
		OTOFL6												0x1D4
		OTBS6												0x1D8
		OTAT6												0x1DC

Table 37: LCSR Register Group

Function		Bits											Offset CRG	
		31		24	23		16	15		8	7			0
Outbound Functions	Outbound Translation 7	OTSAU7											0x1E0	
		OTSAL7											0x1E4	
		OTEAU7											0x1E8	
		OTEAL7											0x1EC	
		OTOFU7											0x1F0	
		OTOFL7											0x1F4	
		OTBS7											0x1F8	
		OTAT7											0x1FC	
			Reserved											
		VMEbus Interrupt Acknowledge	VMEbus IACK 1 (VIACK1)											0x204
			VIACK2											0x208
			VIACK3											0x20C
			VIACK4											0x210
			VIACK5											0x214
			VIACK6											0x218
	VIACK7											0x21C		
	RMW	VMEbus RMW Address Upper (RMWAU)											0x220	
		VMEbus RMW Address Lower (RMWAL)											0x224	
		VMEbus RMW Enable (RMWEN)											0x228	
		VMEbus RMW Compare (RMWC)											0x22C	
		VMEbus RMW Swap (RMWS)											0x230	
	VMEbus Control	VME Master Control (VMCTRL)											0x234	
		VMEbus Control (VCTRL)											0x238	
		VMEbus Status (VSTAT)											0x23C	
	PCI/X Status	PCI/X Control / Status (PCSR)											0x240	
		Reserved												

Table 37: LCSR Register Group

Function		Bits												Offset CRG
		31		24	23		16	15		8	7		0	
VME Filters	VME Filter	VMEbus Filter (VMEFL)												0x250
		Reserved												
VME Exception	VME Exception Status	VMEbus Exception Address Upper (VEAU)												0x260
		VMEbus Exception Address Lower (VEAL)												0x264
		VMEbus Exception Attributes (VEAT)												0x268
		Reserved												0x26C
PCI/X Error	PCI/X Error Status	Error Diagnostic PCI Address Upper (EDPAU)												0x270
		Error Diagnostic PCI Address Lower (EDPAL)												0x274
		Error Diagnostic PCI-X Attribute (EDPXA)												0x278
		Error Diagnostic PCI-X Split Completion Message (EDPXS)												0x27c
		Error Diagnostic PCI Attributes (EDPAT)												0x280
		Reserved												
Inbound Functions	Inbound Translation 0	Inbound Translation Starting Address Upper 0 (ITSAU0)												0x300
		Inbound Translation Starting Address Lower 0 (ITSAL0)												0x304
		Inbound Translation Ending Address Upper 0 (ITEAU0)												0x308
		Inbound Translation Ending Address Lower (ITEAL0)												0x30C
		Inbound Translation Offset Upper 0 (ITOFU0)												0x310
		Inbound Translation Offset Lower 0 (ITOFLO)												0x314
		Inbound Translation Attribute 0 (ITAT0)												0x318
		Reserved												0x31C

Table 37: LCSR Register Group

Function		Bits												Offset CRG
		31		24	23		16	15		8	7		0	
Inbound Functions	Inbound Translation 1	ITSAU1												0x320
		ITSAL1												0x324
		ITEAU1												0x328
		ITEAL1												0x32C
		ITOFU1												0x330
		ITOFL1												0x334
		ITAT0												0x338
		Reserved												0x33C
	Inbound Translation 2	ITSAU2												0x340
		ITSAL2												0x344
		ITEAU2												0x348
		ITEAL2												0x34C
		ITOFU2												0x350
		ITOFL2												0x354
		ITAT2												0x358
		Reserved												0x35C
	Inbound Translation 3	ITSAU3												0x360
		ITSAL3												0x364
		ITEAU3												0x368
		ITEAL3												0x36C
		ITOFU3												0x370
		ITOFL3												0x374
		ITAT3												0x378
		Reserved												0x37C

Table 37: LCSR Register Group

Function		Bits												Offset CRG
		31		24	23		16	15		8	7		0	
Inbound Functions	Inbound Translation 4	ITSAU4												0x380
		ITSAL4												0x384
		ITEAU4												0x388
		ITEAL4												0x38C
		ITOFU4												0x390
		ITOFL4												0x394
		ITAT4												0x398
		Reserved												0x39C
	Inbound Translation 5	ITSAU5												0x3A0
		ITSAL5												0x3A4
		ITEAU5												0x3A8
		ITEAL5												0x3AC
		ITOFU5												0x3B0
		ITOFL5												0x3B4
		ITAT5												0x3B8
		Reserved												0x3BC
	Inbound Translation 6	ITSAU6												0x3C0
		ITSAL6												0x3C4
		ITEAU6												0x3C8
		ITEAL6												0x3CC
		ITOFU6												0x3D0
		ITOFL6												0x3D4
		ITAT6												0x3D8
		Reserved												0x3DC

Table 37: LCSR Register Group

Function		Bits											Offset CRG
		31		24	23		16	15		8	7		
Interrupt Functions	Inbound Translation 7	ITSAU7											0x3E0
		ITSAL7											0x3E4
		ITEAU7											0x3E8
		ITEAL7											0x3EC
		ITOFU7											0x3F0
		ITOFL7											0x3F4
		ITAT7											0x3F8
		Reserved											0x3FC
	Inbound Translation GCSR	GCSR Base Address Upper (GBAU)											0x400
		GCSR Base Address Lower (GBAL)											0x404
		GCSR Attribute (GCSRAT)											0x408
	Inbound Translation CRG	CRG Base Address Upper (CBAU)											0x40C
		CRG Base Address Lower (CBAL)											0x410
		CRG Attribute (CRGAT)											0x414
	Inbound Translation CR/CSR	CR/CSR Offset Upper (CROU)											0x418
		CR/CSR Offset Lower (CROL)											0x41C
		CR/CSR Attribute (CRAT)											0x420

Table 37: LCSR Register Group

Function		Bits												Offset CRG
		31		24	23		16	15		8	7		0	
Interrupt Functions	Inbound Translation Location Monitor	Location Monitor Base Address Upper (LMBAU)												0x424
		Location Monitor Base Address Lower (LMBAL)												0x428
		Location Monitor Attribute (LMAT)												0x42C
	VMEbus Interrupt Control	64-bit Counter Upper (64BCU)												0x430
		64-bit Counter Lower (64BCL)												0x434
		Broadcast Pulse Generator Timer (BPGTR)												0x438
		Broadcast Programmable Clock Timer (BPCTR)												0x43C
		VMEbus Interrupt Control (VICR)												0x440
		Reserved												0x444
	Local Bus Interrupt Control	Interrupt Enable (INTEN)												0x448
		Interrupt Enable Out (INTEO)												0x44C
		Interrupt Status (INTS)												0x450
		Interrupt Clear (INTC)												0x454
		Interrupt Map 1 (INTM1)												0x458
		Interrupt Map 2 (INTM2)												0x45C
			Reserved											

Table 37: LCSR Register Group

Function		Bits												Offset CRG
		31		24	23		16	15		8	7		0	
DMA Controller	DMA Controller 0	DMA Control (DCTL0)												0x500
		DMA Status (DSTA0)												0x504
		DMA Current Source Address Upper (DCSAU0)												0x508
		DMA Current Source Address Lower (DCSAL0)												0x50C
		DMA Current Destination Address Upper (DCDAU0)												0x510
		DMA Current Destination Address Lower (DCDAL0)												0x514
		DMA Current Link Address Upper (DCLAU0)												0x518
		DMA Current Link Address Lower (DCLAL0)												0x51C
		DMA Source Address Upper (DSAU0)												0x520
		DMA Source Address Lower (DSAL0)												0x524
		DMA Destination Address Upper (DDAU0)												0x528
		DMA Destination Address Lower (DDAL0)												0x52C
		DMA Source Attribute (DSAT0)												0x530
		DMA Destination Attribute (DDAT0)												0x534
		DMA Next Link Address Upper (DNLAU0)												0x538
		DMA Next Link Address Lower (DNLAL0)												0x53C
		DMA Count (DCNT0)												0x540
		DMA Destination Broadcast Select (DDBS0)												0x544
		Reserved												

Table 37: LCSR Register Group

Function		Bits												Offset CRG
		31		24	23		16	15		8	7		0	
DMA Controller	DMA Controller 1	DCTL1												0x580
		DSTA1												0x584
		DCSAU1												0x588
		DCSAL1												0x58C
		DCDAU1												0x590
		DCDAL1												0x594
		DCLAU1												0x598
		DCLAL1												0x59C
		DSAU1												0x5A0
		DSAL1												0x5A4
		DDAU1												0x5A8
		DDAL1												0x5AC
		DSAT1												0x5B0
		DDAT1												0x5B4
		DNLAU1												0x5B8
		DNLAL1												0x5BC
		DCNT1												0x5C0
DDBS1												0x5C4		

10.4.4 GCSR Register Group Overview

Table 38: GCSR Register Group

Function		Bits											Offset GCSR/ CRG
		31		24	23		16	15		8	7		
GCSR	Header	Device ID (DEVI)					Vendor ID (VENI)					0x00/ 0x600	
	Control	Control and Status (GCTRL)					Geographic Address (GA)		Revision ID (REVID)			0x04/ 0x604	
	Semaphore	SEMAPHORE0		SEMAPHORE1		SEMAPHORE2		SEMAPHORE3			0x08/ 0x608		
		SEMAPHORE4		SEMAPHORE5		SEMAPHORE6		SEMAPHORE7			0x0C/ 0x60C		
	Mail Box	MBOX0										0x10/ 0x610	
		MBOX1										0x14/ 0x614	
		MBOX2										0x18/ 0x618	
		MBOX3										0x1C/ 0x61C	

10.4.5 CR/CSR Register Group Overview

Table 39: CR/CSR Register Group

Function		Bits											Offset CR/CSR/ CRG
		31		24	23		16	15		8	7		
CR/CSR	CSR	CR/CSR Bit Clear (CSRBCR)											0x7FFF4/ 0xFF4
		CR/CSR Bit Set (CSRBSR)											0x7FFF8/ 0xFF8
		CR/CSR Base Address (CBAR)											0x7FFFC/ 0xFFC

10.4.6 PCFS Register Group Description

This register group represents the PCI/X Configuration Space. This register group can be viewed from PCI/X configuration space and from the CRG.



In many cases a register represented within the PCFS Register Group has different read/write characteristics than the same register represented within the CRG. Generally, the read/write characteristics of the registers within the PCFS Register Group are strictly limited to the abilities defined by the *PCI Local Bus Specification (Revision 2.2)* and *PCI-X Addendum to PCI Local Bus Specification (Revision 1.0b)*.

10.4.7 Vendor ID/ Device ID Registers

Table 40: Vendor ID/ Device ID Registers

Register Name: DEVI/VENI Reset Value: 0x014810E3				Register Offset: PCFS + 0x00 - CRG + 0x000				
Bits	7	6	5	4	3	2	1	0
31:24	DEVI							
23:16	DEVI							
15:8	VENI							
7:0	VENI							

Vendor ID/ Device ID Register

Bits	Name	Function	Type	Reset By	Reset Value
31:16	DEVI	Device ID	R	N/A	0x0148
15:0	VENI	Vendor ID	R	N/A	0x10E3

Device ID Register (DEVI): This is a read-only register that uniquely identifies this particular device. This Tsi148 always returns a value of 0x0148.

Vendor ID Register (VENI): This is a read-only register that identifies the manufacturer of the device. This identifier is allocated by the PCI/X Special Interest Group to ensure uniqueness. 0x10E3 has been assigned to Tundra and is hard wired as a read-only value.

10.4.8 Command/Status Registers

The Status functionality in this register is used to record information for PCI/X bus related events while the command functionality in this register provides course control over the chips ability to generate and respond to PCI/X cycles.

Table 41: Command/Status Register

Register Name: STAT/CMMD PCI Reset Value: 0x PCI-X Reset Value: 0x				Register Offset: PCFS + 0x04 - CRG + 0x004				
Bits	7	6	5	4	3	2	1	0
31:24	DPE	SIGSE	RCVMA	RCVTA	SIGTA	SELTIM1	SELTIM0	DPED
23:16	FAST	Reserved	P66M	CAPL	Reserved			
15:8	Reserved							SERR
7:0	Reserved	PERR	Reserved			MSTR	MEMSP	IOSP

Command/Status Register

Bits	Name	Function	Type	Reset By	PCI Reset Value	PCI-X Reset Value
31	DPE	Detected Parity Error	R/C	P/S/L	0	0
30	SIGSE	Signaled System Error	R/C	P/S/L	0	0
29	RCVMA	Received Master Abort	R/C	P/S/L	0	0
28	RCVTA	Received Target Abort	R/C	P/S/L	0	0
27	SIGTA	Signalled Target Abort	R	N/A	0	0
26	SELTIM1	DEVSEL Timing	R	N/A	0	0
25	SELTIM0	DEVSEL Timing	R	N/A	1	1
24	DPED	Data Parity Error Detected	R/C	P/S/L	0	0
23	FAST	Fast Back-to-Back Capable	R	N/A	1	0
22	Reserved	N/A	R	N/A	0	0
21	P66M	PCI 66 MHz	R	N/A	1	1
20	CAPL	Capabilities List	R	N/A	1	1
19:9	Reserved	N/A	R	N/A	0	0

Command/Status Register

Bits	Name	Function	Type	Reset By	PCI Reset Value	PCI-X Reset Value
8	SERR	System Error Enable	R/W	P/S/L	0	0
7	Reserved	N/A	R	N/A	0	0
6	PERR	Parity Error Response	R/W	P/S/L	0	0
5:3	Reserved	N/A	R	N/A	0	0
2	MSTR	Bus Master Enable	R/W	P/S/L	0	0
1	MEMSP	Memory Space Enable	R/W	P/S/L	0	0
0	IOSP	I/O Space Enable	R	N/A	0	0

DPE (Data Parity Error): This bit is set whenever a parity error is detected, even if the parity error response is disabled (see bit PERR in the [Section 10.4.8 on page 218](#)). It is cleared by writing it to 1 - writing a 0 has no effect.

SIGSE (Signaled System Error): This bit is set whenever the Tsi148 asserts SERR_. The register is cleared by writing it to 1 while writing a 0 has no effect.

RCVMA (Received Master Abort): This bit is set when a master transaction (except for Special Cycles) is terminated by a master-abort. It is cleared by writing it to 1; writing a 0 has no effect.

RCVTA (Received Target Abort): This bit is set when a master transaction is terminated by a target-abort. The register is cleared by writing it to 1 while writing a 0 has no effect.

SIGTA (Signalled Target Abort): The Tsi148 does not generate a target abort, therefore this bit is hard-wired to a logic 0.

SELTIM (DEVSEL Timing): This field indicates that Tsi148 always asserts DEVSEL_ as a *medium* responder.

DPED (Data Parity Error Detected): This bit is set when three conditions are met:

1. The Tsi148 asserted PERR_ itself or observed PERR_ asserted
2. The Tsi148 was the PCI/X Master for the transfer in which the error occurred
3. The PERR bit is set. This bit is cleared by writing it to 1; writing a 0 has no effect.

FAST (Fast Back-to-Back Capable): This bit indicates that the Tsi148 is capable of accepting fast back-to-back transactions with different targets.

P66M (PCI 66 MHz): This bit indicates the Tsi148 is capable of supporting a 66.67 MHz PCI/X bus.

CAPL (Capabilities List): This bit indicates that the address at offset 0x34 is a pointer for a New Capabilities linked list.

SERR (System Error Enable): This bit enables the SERR_ output pin. If cleared, the **Tsi148** never drives SERR_. If set, the **Tsi148** drives SERR_ active when a system error is detected.

PERR (Parity Error Response): This bit enables the PERR_ output pin. If cleared, the Tsi148 never drives PERR_. If set, the Tsi148 drives PERR_ active when a data parity error is detected.

MSTR (Bus Master Enable): If set, the Tsi148 may act as a master on PCI/X. If cleared, the Tsi148 may not act as a master.

MEMSP (Memory Space Enable): If set, the Tsi148 does respond to PCI/X memory space accesses when appropriate. If cleared, the Tsi148 does not respond to PCI/X memory space accesses.

IOSP (I/O Space Enable): This bit is hard wired to zero. The Tsi148 does not respond to PCI/X I/O space accesses.

10.4.9 Revision ID / Class Code Registers

Table 42: Revision ID / Class Code Register

Register Name: CLAS/REVI Reset Value: 0x				Register Offset: PCFS + 0x08 - CRG + 0x008				
Bits	7	6	5	4	3	2	1	0
31:24	BCLAS							
23:16	SCLAS							
15:8	PIC							
7:0	REVI							

Revision ID / Class Code Register

Bits	Name	Function	Type	Reset By	Reset Value
31:24	BCLAS	Base Class Code Register	R	N/A	0x06
23:16	SCLAS	Sub Class Code Register	R	N/A	0x80
15:8	PIC	Program Interface Code Register	R	N/A	0x00
7:0	REVI	Revision ID Register	R	N/A	0x01

BCLAS (Base Class Code Register): This is a read-only register that identifies the base class code of the Tsi148. The Tsi148 always returns a value of 0x06.

SCLAS (Sub Class Code Register): This is a read-only register that identifies the sub class code of the Tsi148. The Tsi148 always returns a value of 0x80.

PIC (Program Interface Code Register): This is a read-only register that identifies the program interface code of the Tsi148. The Tsi148 always returns a value of 0x00.

REVI (Revision ID Register): This is a read-only register that identifies the Tsi148 revision level.

10.4.10 Cache Line Size / Master Latency Timer / Header Type Registers

Table 43: Cache Line Size / Master Latency Timer / Header Type Register

Register Name: HEAD/MLAT/CLSZ PCI Reset Value: 0x PCI-X Reset Value: 0x	Register Offset: PCFS + 0x0C - CRG + 0x00C
--	---

Bits	7	6	5	4	3	2	1	0
31:24	Reserved							
23:16	HEAD							
15:8	MLAT							
7:0	CLSZ							

Cache Line Size / Master Latency Timer / Header Type Register

Bits	Name	Function	Type	Reset By	PCI Reset Value	PCI-X Reset Value
31:24	Reserved	N/A	R	N/A	0x00	0x00
23:16	HEAD	Header Type	R	N/A	0x00	0x00
15:08	MLAT	Master Latency Timer	R/W	P/S/L	0x00	0x40
7:0	CLSZ	Cache Line Size	R/W	P/S/L	0x00	0x00

CLSZ (Cache Line): These bits represent the number of 32-bit words that define a cache-line. A cache line is defined as 32-bytes, which is eight 32-bit words. If a value of 0x08 is written to this register, the value is retained. If any other value is written to this register, a value of 0x00 is retained.

The *PCI Local Bus Specification (Revision 2.2)* states that this register must power up to all zeros. The Tsi148 does not generate memory write and invalidate command. This register is only used to inform other PCI/X masters of the supported cache-line size for read, read line, and read multiple commands.

MLAT (Master Latency Timer): These bits represent the value used for the Master Latency Timer. The Master Latency Timer specifies the amount of PCI/X clock periods that Tsi148 can remain on the PCI/X bus during burst cycles after GNT_ is taken away. The MLAT bits provides a minimum granularity of the 8 PCI/X clock periods.

The *PCI Local Bus Specification (Revision 2.2)* states that this register must power up to all zeros in PCI mode. Severe performance degradation may result if this register is not adjusted from the reset value. This register is initialized to 0x40 in PCI-X mode.

HEAD (Header Type): This is a read-only register that identifies this Tsi148 as a Single Function device.

10.4.11 Memory Base Address Lower Register

The MBARL register controls access to the Combined Register Group (CRG).

Table 44: Memory Base Address Lower Register

Register Name: MBAR Reset Value: 0x				Register Offset: PCFS + 0x10 - CRG + 0x010				
Bits	7	6	5	4	3	2	1	0
31:24	BASEL							
23:16	BASEL							
15:8	BASEL				Reserved			
7:0	Reserved				PRE	MTYP1	MTYP0	IO/MEM

Memory Base Address Lower Register

Bits	Name	Function	Type	Reset By	Reset Value
31:12	BASEL	Base Address Lower	R/W	P/S/L	0x00
11:4	Reserved	N/A	R	N/A	0x00
3	PRE	Prefetch	R	N/A	0x00
2	MTYP1	Memory Type	R	N/A	0x01
1	MTYP0	Memory Type	R	N/A	0x00
0	IO/MEM	I/O Space Indicator	R	N/A	0x00

BASEL (Base Address Lower): These bits define the memory space base address of the (CRG).

PRE (Prefetch): This is a read-only register that reflects the ability of the function to support prefetching. The CRG does not support prefetching.

MTYPx (Memory Type): These bits are hard-wired to 10b to indicate that the CRG can be located anywhere in the 64-bit address space.

IO/MEM (I/O Space Indicator): This bit is set to a zero indicating this resource is a memory space resource. The CRG can only be mapped to memory space.

10.4.12 Memory Base Address Upper Register

The MBARU register controls access to the Combined Register Group (CRG).

Table 45: Memory Base Address Upper Register

Register Name: MBARU Reset Value: 0x				Register Offset: PCFS + 0x14 - CRG + 0x014				
Bits	7	6	5	4	3	2	1	0
31:24	BASEU							
23:16	BASEU							
15:8	BASEU							
7:0	BASEU							

Memory Base Address Upper Register

Bits	Name	Function	Type	Reset By	Reset Value
31:0	BASEU	Base Address Upper	R/W	P/S/L	0x00

BASEU (Base Address Upper): These bits define the memory space base address of the (CRG).

10.4.13 Subsystem Vendor ID/ Subsystem ID Registers

Table 46: Subsystem Vendor ID/ Subsystem ID Register

Register Name: SUBI/SUBV Reset Value: 0x				Register Offset: PCFS + 0x2C - CRG + 0x02C				
Bits	7	6	5	4	3	2	1	0
31:24	SUBI							
23:16	SUBI							
15:8	SUBV							
7:0	SUBV							

Subsystem Vendor ID/ Subsystem ID Register

Bits	Name	Function	PCFS Space Type	CRG Space Type	Reset By	Reset Value
31:16	SUBI	Subsystem ID	R	R/W	P/S/L	0x0000
15:0	SUBV	Subsystem Vendor ID	R	R/W	P/S/L	0x10E3

SUBI (Subsystem ID): This is a read-only register from within the PCI/X configuration space (PCFS), and may be written at any time from within the Combined Register Group (CRG). The SUBI register provides a second level of identification for this particular device. This register defaults to 0x0000 upon the release of reset.

SUBV (Subsystem Vendor ID): This is a read-only register from within the PCI/X configuration space, and may be written at any time from within the Combined Register Group. The SUBV register provides a second level of identification for the manufacturer of this particular device. This identifier is allocated by the PCI/X Special Interest Group to ensure uniqueness. This register is configured to the Tundra value of 0x10E3 upon release of reset.

10.4.14 Capabilities Pointer Register

This register contains the offset to the first entry in the capabilities list.

Table 47: Capabilities Pointer Register

Register Name: CAPP Reset Value: 0x				Register Offset: PCFS + 0x3C - CRG + 0x03C				
Bits	7	6	5	4	3	2	1	0
31:24	Reserved							
23:16	Reserved							
15:8	Reserved							
7:0	CAPP							

Capabilities Pointer Register

Bits	Name	Function	Type	Reset By	Reset Value
31:8	Reserved	N/A	R	N/A	0x00
15:0	CAPP	Capabilities Pointer	R	N/A	0x40

10.4.15 Interrupt Line/interrupt PIn/Minimum Grant/Maximum Latency Registers

Table 48: Interrupt Line/Interrupt PIn/Minimum Grant/Maximum Latency Register

Register Name: MXLA/MNGN/INTP/INTL Reset Value: 0x				Register Offset: PCFS + 0x3C - CRG + 0x03C				
Bits	7	6	5	4	3	2	1	0
31:24	MXLA							
23:16	MNGN							
15:8	INTP							
7:0	INTL							

Interrupt Line/Interrupt PIn/Minimum Grant/Maximum Latency Register

Bits	Name	Function	PCFS Space Type	CRG Space Type	Reset By	Reset Value
31:24	MXLA	Maximum Latency	R	R/W	P/S/L	0x00
23:16	MNGN	Minimum Grant	R	R/W	P/S/L	0x00
15:8	INTP	Interrupt Pin	R	see Table 49	P/S/L	0x01
7:0	INTL	Interrupt Line	R/W	R/W	P/S/L	0x00

MXLA (Maximum Latency): This is a read-only register from the PCI/X configuration space, and may be written at any time from within the Combined Register Group. The MXLA register specifies how often access to the PCI/X bus is required. The value is presented in units of 0.25 us. This register defaults 0x00 following the release of reset which indicates that there are no particular latency requirements.

MNGN (Minimum Grant): This is a read-only register from the PCI/X configuration space, and may be written at any time from within the Combined Register Group. The MNGN register specifies how long of a burst period is required. The value is presented in units of 0.25 us. This register defaults to 0x00 following the release of reset which indicates that there are no particular grant requirements.

INTP (Interrupt Pin): This register contains information pertaining to the PCI/X interrupt pin being driven. This register is read-only from the PCI/X configuration space, and may be written at any time from within the Combined Register Group. [Table 49](#) shows which bits in the INTP field are read only from within the CRG register group and which bits are both read and write.

Table 49: CRG Space Type

Register Bit	INTP Field
15	R
14	R
13	R
12	R
11	R
10	R/W
9	R/W
8	R/W

This Tsi148 is a single function device and is limited by the *PCI Local Bus Specification (Revision 2.2)* to only driving INTA_. In special cases, this Tsi148 can be programmed to drive any one of the four PCI/X interrupts.

This register may be modified to show which of the four interrupt lines is being driven. The recommended encoding of this field is shown in [Table 50](#):

Table 50: INTP INTx Encoding

INTP	PCI/X Interrupt
0x000	Undefined
0x001	INTA_
0x010	INTB_
0x011	INTC_
0x100	INTD_
0x101 - 0x111	Undefined

Note that the selection of a particular INTx line is handled by the interrupt map registers. The **INTP** register is for reference only and does not control any hardware.

INTL (Interrupt Line): This register contains interrupt routing information. This Tsi148 does not have any hardware associated with this register, and is not affected by the contents of this register. Initialization software can write interrupt routing information into this register during system configuration.

10.4.16 PCI-X Capabilities Register

Table 51: PCI-X Capabilities Register

Register Name: PCIXCAP Reset Value: 0x				Register Offset: PCFS + 0x40 - CRG + 0x040				
Bits	7	6	5	4	3	2	1	0
31:24	Reserved							
23:16	Reserved	MOST			MMRBC		ERO	DPERE
15:8	NCAPP							
7:0	CAPID							

PCI-X Capabilities Register

Bits	Name	Function	PCFS Space Type	Reset By	Reset Value
31:23	Reserved	N/A	R	N/A	0x00
22:20	MOST	Maximum Outstanding Split Transactions	R/W	P/S/L	010b
19:18	MMRBC	Maximum Memory Read Byte Count	R/W	P/S/L	0x00
17	ERO	Enable Relaxed Ordering	R	N/A	0x00
16	DPERE	Data Parity Recovery Enable	R/W	P/S/L	0x00
15:8	NCAPP	Next Capabilities Pointer	R	N/A	0x00
7:0	CAPID	Capabilities ID	R	N/A	0x07

MOST (Maximum Outstanding Split Transactions): Three outstanding split transactions are supported. Changing the value of this field decreases the maximum number of outstanding split transactions:

Table 52: MOST Encoding

MOST	Maximum Outstanding
000b	1
001b	2
010b	3
011b - 111b	3

MMRBC (Maximum Memory Read Byte Count): This field sets the maximum byte count the device uses when initiating a read sequence with one of the burst memory commands:

Table 53: MMRBC Encoding

MMRBC	Byte Count
00b	512
01b	1024
10b	2048
11b	4096

ERO (Enable Relaxed Ordering): The Tsi148 does not support relaxed ordering. When this field is read, the value is always zero.

DPERE (Data Parity Recovery Enable): When this bit is set and the device is in PCI-X mode, the Tsi148 does not assert SERR_ when the master data parity error bit is set. When this bit is clear and the device is in PCI-X mode, the Tsi148 asserts SERR_ when the master data parity error bit is set.

NCAPP (Next Capabilities Pointer): This field points to the next item in the Capabilities List. A zero indicates that this is the final item in the list.

CAPID (Capabilities ID): This field defines this item in the capabilities list as a PCI-X register set. When this field is read, the value is always 0x07.

10.4.17 PCI-X Status Register

Table 54: PCI-X Status Register

Register Name: PCIXSTAT Reset Value: 0x				Register Offset: PCFS + 0x44 - CRG + 0x044				
Bits	7	6	5	4	3	2	1	0
31:24	Reserved		RSECM	DMCRS			DMOST	
23:16	DMOST	DMMRC		DC	USC	SCD	133C	64D
15:8	BN							
7:0	DN				FN			

PCI-X Status Register

Bits	Name	Function	PCFS Space Type	Reset By	Reset Value
31:30	Reserved	N/A	R	N/A	0x00
29	RSECM	Received Split Completion Error Message	R	P/S/L	0x00
28:26	DMCRS	Designed Maximum Cumulative Read Size	R/C	N/A	0x01
25:23	DMOST	Designed Maximum Outstanding Split Transactions	R	N/A	0x02
22:21	DMMRC	Designed Maximum Memory Read Byte Count	R	N/A	0x03
20	DC	Device Complexity	R	N/A	0x01
19	USC	Unexpected Split Completion	R/C	P/S/L	0x00
18	SCD	Split Completion Discarded	R/C	P/S/L	0x00
17	133C	133 MHz Capable	R	N/A	0x01
16	64D	64-bit Device	R	N/A	0x01
15:8	BN	Bus Number	R	N/A	0xFF
7:3	DN	Device Number	R	N/A	0x1F
2:0	FN	Function Number	R	N/A	0x00

RSECM (Received Split Completion Error Message): This bit is set if a Split Completion Message is received with the Split Completion Error attribute set. This bit is cleared by

writing a one to it.

DMCRS (Designed Maximum Cumulative Read Size): These bits depend on the value of the MMRBC field (see [Table 10.4.16 on page 231](#)) as shown in the following table:

Table 55: DMCRS Encoding

MMRBC	DMCRS
00b	001b
01b	010b
10b	011b
11b	100b

DMOST (Designed Maximum Outstanding Split Transactions): These bits always return a value of two. The Tsi148 can have up to three outstanding read transactions.

DMMRC (Designed Maximum Memory Read Byte Count): These bits always return a value of three indicating that the Tsi148 has a maximum memory read byte count of 4096 bytes.

DC (Device Complexity): This bit always returns a value of one indicating that the Tsi148 is a bridge device.

USC (Unexpected Split Completion): This bit is set if an unexpected Split Completion is received. This bit is cleared by writing a one to it.

SCD (Split Completion Discarded): This bit is set if a Split Completion is discarded because the requestor would not accept it. This bit is cleared by writing a one to it.

133C (133 MHz Capable): This bit always returns a value of one indicating that the Tsi148 is capable of operating at 133 MHz.

64D (64-bit Device): This bit always returns a value of one indicating that the Tsi148 has a 64-bit AD interface.

BN (Bus Number): This field indicates the number of the bus segment the Tsi148 is attached to. During the attribute phase of a configuration write, the bus number is latched from AD[7:0]. This number is used as part of the Requester ID and Completer ID.

DN (Device Number): This field indicates the chips device number. During the address phase of a configuration write, the device number is latched from AD[15:11]. This number is used as part of the Requester ID and Completer ID.

FN (Function Number): This field indicates the number of this function and always returns a value of zero. This number is used as part of the Requester ID and Completer ID.

10.4.18 LCSR Register Group Description

This section defines the Local Control and Status Registers.

10.4.19 Outbound Translation Starting Address Upper (0-7) Registers

The Outbound Translation Starting Address Upper Registers (OTSAU0-OTSAU7) contain address information associated with the mapping of PCI/X Memory space to VMEbus space. The outbound PCI/X address is decoded when the PCI/X address is greater than or equal to the start address and less than or equal to the end address.

Table 56: Outbound Translation Starting Address Upper (0-7) Register

Register Name: OTSAUx Reset Value: 0x00000000				Register Offset: OTSAU0: CRG + 0x100 OTSAU1: CRG + 0x120 OTSAU2: CRG + 0x140 OTSAU3: CRG + 0x160 OTSAU4: CRG + 0x180 OTSAU5: CRG + 0x1A0 OTSAU6: CRG + 0x1C0 OTSAU7: CRG + 0x1E0				
Bits	7	6	5	4	3	2	1	0
31:0	STAU							

Outbound Translation Starting Address Upper (0-7) Register

Bits	Name	Function	PCFS Space Type	Reset By	Reset Value
31:0	STAU	Start Address Upper	R/W	P/S/L	0x00

STAU (Start Address Upper): This field determines the start address of a particular memory area on the PCI/X bus which is used to access VMEbus resources. The value of this field is compared with A63-A32 of the PCI/X bus address.

10.4.20 Outbound Translation Starting Address Lower (0-7) Registers

The Outbound Translation Starting Address Lower Registers (OTSAL0-OTSAL7) contain address information associated with the mapping of PCI/X Memory space to VMEbus space. The outbound PCI/X address is decoded when the PCI/X address is greater than or equal to the start address and less than or equal to the end address.

Table 57: Outbound Translation Starting Address Lower (0-7) Register

Register Name: OTSALx Reset Value: 0x00000000	Register Offset: OTSAL0: CRG + 0x104 OTSAL1: CRG + 0x124 OTSAL2: CRG + 0x144 OTSAL3: CRG + 0x164 OTSAL4: CRG + 0x184 OTSAL5: CRG + 0x1A4 OTSAL6: CRG + 0x1C4 OTSAL7: CRG + 0x1E4
--	--

Bits	7	6	5	4	3	2	1	0
31:16	STAL							
15:0	Reserved							

Outbound Translation Starting Address Lower (0-7) Register

Bits	Name	Function	PCFS Space Type	Reset By	Reset Value
31:16	STAL	Start Address Lower	R/W	P/S/L	0x00
15:0	Reserved	N/A	R	N/A	0x00

STAL (Start Address Lower): This field determines the start address of a particular memory area on the PCI/X bus which is used to access VMEbus resources. The value of this field is compared with A31-A16 of the PCI/X bus address.

10.4.21 Outbound Translation Ending Address Upper (0-7) Registers

The Outbound Translation Ending Address Upper Registers (OTEAU0-OTEAU7) contain address information associated with the mapping of PCI/X Memory space to VMEbus space. The outbound PCI/X address is decoded when the PCI/X address is greater than or equal to the start address and less than or equal to the end address.

Table 58: Outbound Translation Ending Address Upper (0-7) Register

Register Name: OTEAUx Reset Value: 0x00000000	Register Offset: OTEAU0: CRG + 0x108 OTEAU1: CRG + 0x128 OTEAU2: CRG + 0x148 OTEAU3: CRG + 0x168 OTEAU4: CRG + 0x188 OTEAU5: CRG + 0x1A8 OTEAU6: CRG + 0x1C8 OTEAU7: CRG + 0x1E8
--	--

Bits	7	6	5	4	3	2	1	0
31:0	ENDU							

Outbound Translation Ending Address Upper (0-7) Register

Bits	Name	Function	PCFS Space Type	Reset By	Reset Value
31:0	ENDU	End Address Upper	R/W	P/S/L	0x00

ENDU (End Address Upper): This field determines the end address of a particular memory area on the PCI/X bus which is used to access VMEbus resources. The value of this field is compared with A63-A32 of the PCI/X bus address.

10.4.22 Outbound Translation Ending Address Lower (0-7) Registers

The Outbound Translation Ending Address Lower Registers (OTEAL0-OTEAL7) contain address information associated with the mapping of PCI/X Memory space to VMEbus space. The outbound PCI/X address is decoded when the PCI/X address is greater than or equal to the start address and less than or equal to the end address.

Table 59: Outbound Translation Ending Address Lower (0-7) Register

Register Name: OTEALx Reset Value: 0x00000000	Register Offset: OTEAL0: CRG + 0x10C OTEAL1: CRG + 0x12C OTEAL2: CRG + 0x14C OTEAL3: CRG + 0x16C OTEAL4: CRG + 0x18C OTEAL5: CRG + 0x1AC OTEAL6: CRG + 0x1CC OTEAL7: CRG + 0x1EC
--	--

Bits	7	6	5	4	3	2	1	0
31:16	ENDL							
15:0	Reserved							

Outbound Translation Starting Address Lower (0-7 Register

Bits	Name	Function	PCFS Space Type	Reset By	Reset Value
31:16	ENDL	End Address Lower	R/W	P/S/L	0x00
15:0	Reserved	N/A	R	N/A	0x00

ENDL (End Address Lower): This field determines the end address of a particular memory area on the PCI/X bus which is used to access VMEbus resources. The value of this field is compared with A31-A16 of the PCI/X bus address.

10.4.23 Outbound Translation Offset Upper (0-7) Registers

The Outbound Translation Offset Upper Registers (OTOFU0-OTOFU7) contain information associated with the mapping of PCI/X Memory space to VMEbus space.

Table 60: Outbound Translation Offset Upper (0-7) Register

Register Name: OTOFUx Reset Value: 0x00000000	Register Offset: OTOFU0: CRG + 0x110 OTOFU1: CRG + 0x130 OTOFU2: CRG + 0x150 OTOFU3: CRG + 0x170 OTOFU4: CRG + 0x190 OTOFU5: CRG + 0x1B0 OTOFU6: CRG + 0x1D0 OTOFU7: CRG + 0x1F0
--	--

Bits	7	6	5	4	3	2	1	0
31:0	OFFU							

Outbound Translation Offset Upper (0-7) Register

Bits	Name	Function	PCFS Space Type	Reset By	Reset Value
31:0	OFFU	Offset Upper	R/W	P/S/L	0x00

OFFU (Offset Upper): This field contains the offset that is added to PCI/X address lines A63-A32 to create the VMEbus address.

10.4.24 Outbound Translation Offset Lower (0-7) Registers

The Outbound Translation Offset Lower Registers (OTOFL0-OTOFL7) contain address information associated with the mapping of PCI/X Memory space to VMEbus space.

Table 61: Outbound Translation Offset Lower (0-7) Register

Register Name: OTOFLx Reset Value: 0x00000000				Register Offset: OTOFL0: CRG + 0x114 OTOFL1: CRG + 0x134 OTOFL2: CRG + 0x154 OTOFL3: CRG + 0x174 OTOFL4: CRG + 0x194 OTOFL5: CRG + 0x1B4 OTOFL6: CRG + 0x1D4 OTOFL7: CRG + 0x1F4				
Bits	7	6	5	4	3	2	1	0
31:16	OFFL							
15:0	Reserved							

Outbound Translation Starting Address Lower (0-7) Register

Bits	Name	Function	PCFS Space Type	Reset By	Reset Value
31:16	OFFL	Offset Lower	R/W	P/S/L	0x00
15:0	Reserved	N/A	R	N/A	0x00

OFFL (Offset Lower): This field contains the offset that is added to PCI/X address lines A31-A16 to create the VMEbus address.

10.4.25 Outbound Translation 2eSST Broadcast Select (0-7) Registers

The Outbound Translation 2eSST Broadcast Select Registers (OTBS0-OTBS7) contain information associated with the mapping of PCI/X Memory space to VMEbus space.

The 2eSST protocol supports broadcast transfers which allow a master to write the same data to multiple slaves with a single transfer. When this functionality is used, this register determines which VMEbus slaves participates and receives the broadcast data.

Table 62: Outbound Translation 2eSST Broadcast Select (0-7) Register

Register Name: OTBSx Reset Value: 0x00000000	Register Offset: OTBS0: CRG + 0x118 OTBS1: CRG + 0x138 OTBS2: CRG + 0x158 OTBS3: CRG + 0x178 OTBS4: CRG + 0x198 OTBS5: CRG + 0x1B8 OTBS6: CRG + 0x1D8 OTBS7: CRG + 0x1F8
---	--

Bits	7	6	5	4	3	2	1	0
31:21	Reserved							
20:0	2eBS							

Outbound Translation 2eSST Broadcast Select (0-7) Register

Bits	Name	Function	PCFS Space Type	Reset By	Reset Value
31:21	Reserved	N/A	R	N/A	0x00
20:0	2eBS	2eSST Broadcast Select	R/W	P/S/L	0x00

2eBS (2eSST Broadcast Select): This register contains the 2eSST broadcast select bits. Each bit corresponds to one of the 21 possible slaves. The 2eSST master broadcasts this field during address phase three. Register bit 20 corresponds to VMEbus address line A21 and register bit 0 corresponds to VMEbus address line A1.

10.4.26 Outbound Translation Attribute (0-7) Registers

The Outbound Translation Attribute Registers (OTAT0-OTAT7) contain information associated with the mapping of PCI/X Memory space to VMEbus space.

Table 63: Outbound Translation Attribute (0-7) Register

Register Name: OTATx Reset Value: 0x00000000	Register Offset: OTAT0: CRG + 0x11C OTAT1: CRG + 0x13C OTAT2: CRG + 0x15C OTAT3: CRG + 0x17C OTAT4: CRG + 0x19C OTAT5: CRG + 0x1BC OTAT6: CRG + 0x1DC OTAT7: CRG + 0x1FC
---	---

Bits	7	6	5	4	3	2	1	0
31:24	EN	Reserved						
23:16	Reserved					MRPFD	PFS1	PFS0
15:8	Reserved		2eSSTM2	2eSSTM1	2eSSTM0	TM2	TM1	TM0
7:0	DBW1	DBW0	SUP	PGM	ADMODE3	ADMODE2	ADMODE1	ADMODE0

Outbound Translation Attribute (0-7) Register

Bits	Name	Function	PCFS Space Type	Reset By	Reset Value
31	EN	Enable	R/W	P/S/L	0x00
30:19	Reserved	N/A	R	N/A	0x00
18	MRPFD	Memory Read Prefetch Disable	R/W	P/S/L	0x00
17	PFS1	Prefetch Size	R/W	P/S/L	0x00
16	PFS0	Prefetch Size	R/W	P/S/L	0x00
15:14	Reserved	N/A	R	N/A	0x00
13	2eSSTM2	2eSST Mode	R/W	P/S/L	0x00
12	2eSSTM1	2eSST Mode	R/W	P/S/L	0x00
11	2eSSTM0	2eSST Mode	R/W	P/S/L	0x00
10	TM2	Transfer Mode	R/W	P/S/L	0x00

Outbound Translation Attribute (0-7) Register

Bits	Name	Function	PCFS Space Type	Reset By	Reset Value
9	TM1	Transfer Mode	R/W	P/S/L	0x00
8	TM0	Transfer Mode	R/W	P/S/L	0x00
7	DBW1	VMEbus Data Bus Width	R/W	P/S/L	0x00
6	DBW0	VMEbus Data Bus Width	R/W	P/S/L	0x00
5	SUP	VMEbus Supervisory Mode	R/W	P/S/L	0x00
4	PGM	VMEbus Program Mode	R/W	P/S/L	0x00
3	ADMODE3	Address Mode	R/W	P/S/L	0x00
2	ADMODE2	Address Mode	R/W	P/S/L	0x00
1	ADMODE1	Address Mode	R/W	P/S/L	0x00
0	ADMODE0	Address Mode	R/W	P/S/L	0x00

EN (Enable): If set, the corresponding outbound translation function is enabled.

MRPFD (Memory Read Prefetch Disable): If set, prefetching is disabled for all memory read commands. If cleared, a cache line is prefetched when a PCI/X bus memory read burst is received.

PFS (Prefetch Size): This field sets the data read prefetch size for PCI/X bus read multiple commands.

Table 64: Prefetch Size

PFS	Prefetch Size
00b	2 Cache Lines
01b	4 Cache Lines
10b	8 Cache Lines
11b	16 Cache Lines

2eSSTM (2eSST Mode): This field defines the 2eSST Transfer Rate.

Table 65: 2eSST Transfer Rate

2eSSTM	Transfer Rate
000b	160 MB/s
001b	267 MB/s
010b	320 MB/s
011b-111b	Reserved

TM (Transfer Mode): This field defines the VMEbus transfer mode.

Table 66: VMEbus Transfer Mode

TM	Transfer Mode
000b	SCT
001b	BLT
010b	MBLT
011b	2eVME
100b	2eSST
101b	2eSST Broadcast
110b	Reserved
111b	Reserved

DBW (VMEbus Data Bus Width): These bits define the maximum data bus width for VMEbus transfers initiated by the corresponding outbound translation function. These bits apply to SCT and BLT transfers. MBLT, 2eVME and 2eSST transfers are always 64-bit.

Table 67: VMEbus Data Bus Width

DBW	Data Bus Width
00b	16 bit
01b	32 bit
10b	Reserved
11b	Reserved

SUP (VMEbus Supervisory Mode): When this bit is set the AM code indicates Supervisory Access, when required. When this bit is cleared the AM code indicates Non-Privileged Access.

PGM (VMEbus Program Mode): When this bit is set the AM code indicates Program Access. When this bit is cleared the AM code indicates Data Access.

AMODE (Address Mode): This field defines the VMEbus Address mode.

Table 68: VMEbus Address Mode

AMODE	Address Mode
0000b	A16
0001b	A24
0010b	A32
0011b	Reserved
0100b	A64
0101b	CR/CSR
0110b	Reserved
0111b	Reserved
1000b	User1 (AM 0100xxb)
1001b	User2 (AM 0101xxb)
1010b	User3 (AM 0110xxb)
1011b	User4 (AM 0111xxb)
1100b	Reserved
1101b	Reserved
1110b	Reserved
1111b	Reserved

When the User1-User4 modes are used, the AM[1] bit is defined by the SUP bit and the AM[0] bit is defined by the PGM bit.

10.4.27 VMEbus IACK (1-7) Registers

Reading these registers causes an interrupt acknowledge cycle on the VMEbus. A 32-bit read of these registers causes a 32-bit IACK cycle on the VMEbus. A 16-bit read of these registers causes a 16-bit IACK cycle on the VMEbus. An 8-bit read of these registers causes an 8-bit IACK cycle on the VMEbus. Since most VMEbus interrupters support 8-bit IACK cycles, byte reads from offset three should be used to retrieve the interrupt vector. Writes to this register are ignored.

Table 69: VMEbus IACK (1-7) Register

Register Name: VIACKx Reset Value: 0xxxxxxxx	Register Offset: VIACK1: CRG + 0x204 VIACK2: CRG + 0x208 VIACK3: CRG + 0x20C VIACK4: CRG + 0x210 VIACK5: CRG + 0x214 VIACK6: CRG + 0x218 VIACK7: CRG + 0x21C
---	---

Bits	7	6	5	4	3	2	1	0
31:0	VIACK							

VMEbus IACK (1-7) Register

Bits	Name	Function	PCFS Space Type	Reset By	Reset Value
31:0	VIACK	VMEbus IACK	R	N/A	0xxx

10.4.28 VMEbus Read-Modify-Write (RMW) Address Upper Register

This register defines the upper bits (63:32) of the PCI/X bus address for the RMW cycle. Refer to [Section 2.5 on page 79](#) for more information on RMW cycles.

Table 70: VMEbus RMW Address Upper Register

Register Name: RMWAU Reset Value: 0x00000000				Register Offset: CRG + 0x220				
Bits	7	6	5	4	3	2	1	0
31:0	RMWAU							

VMEbus RMW Address Upper Register

Bits	Name	Function	PCFS Space Type	Reset By	Reset Value
31:0	RMWAU	VMEbus RMW Address Upper	R/W	P/S/L	0x00

10.4.29 VMEbus RMW Address Lower Register

This register defines the lower bits (31:2) of the PCI/X bus address for the RMW cycle.

Table 71: VMEbus RMW Address Lower Register

Register Name: RMWAL Reset Value: 0x00000000	Register Offset: CRG + 0x224
---	-------------------------------------

Bits	7	6	5	4	3	2	1	0
31:0	RMWAL							

VMEbus RMW Address Lower Register

Bits	Name	Function	PCFS Space Type	Reset By	Reset Value
31:0	RMWAL	VMEbus RMW Address Lower	R/W	P/S/L	0x00

10.4.30 VMEbus RMW Enable Register

This register defines the bits which are involved in the compare and swap operation of the RMW cycle.

Table 72: VMEbus RMW Enable Register

Register Name: RMWEN Reset Value: 0x00000000				Register Offset: CRG + 0x228				
Bits	7	6	5	4	3	2	1	0
31:0	RMWEN							

VMEbus RMW Enable Register

Bits	Name	Function	PCFS Space Type	Reset By	Reset Value
31:0	RMWEN	VMEbus RMW Enable	R/W	P/S/L	0x00

10.4.31 VMEbus RMW Compare Register

This register defines the bits which are compared with the data read from the VMEbus.

Table 73: VMEbus RMW Compare Register

Register Name: RMWC Reset Value: 0x00000000	Register Offset: CRG + 0x22C
--	-------------------------------------

Bits	7	6	5	4	3	2	1	0
31:0	RMWC							

VMEbus RMW Compare Register

Bits	Name	Function	PCFS Space Type	Reset By	Reset Value
31:0	RMWC	VMEbus RMW Compare	R/W	P/S/L	0x00

10.4.32 VMEbus RMW Swap Register

This register defines the bits which are written to the VMEbus when the compare is successful.

Table 74: VMEbus RMW Swap Register

Register Name: RMWS Reset Value: 0x00000000				Register Offset: CRG + 0x230				
Bits	7	6	5	4	3	2	1	0
31:0	RMWS							

VMEbus RMW Swap Register

Bits	Name	Function	PCFS Space Type	Reset By	Reset Value
31:0	RMWS	VMEbus RMW Swap	R/W	P/S/L	0x00

10.4.33 VME Master Control Register

The VME Master Control Registers gives the user various control mechanisms on how Tsi148 behaves on the VMEbus as a master. The various data throttling methods are used by the Tsi148 VME Master in all cases when Tsi148 is master on the VMEbus including DMA accesses.

Table 75: VME Master Control Register

Register Name: VMCTRL Reset Value: 0x				Register Offset: CRG + 0x234				
Bits	7	6	5	4	3	2	1	0
31:24	Reserved			VSA	VS	DHB	DWB	
23:16	Reserved		RMWEN	Reserved			A64DS	
15:8	Reserved	VTOFF		Reserved	VTON			
7:0	Reserved		VREL		VFAIR	VREQL		

VME Master Control Register

Bits	Name	Function	PCFS Space Type	Reset By	Reset Value
31:28	Reserved	N/A	R	N/A	0x00
27	VSA	VMEbus Stop Acknowledge	R	-	0x00
26	VS	VMEbus Stop	R/W	P/S/L	0x00
25	DHB	Device Has Bus	R	-	0x00
24	DWB	Device Wants Bus	R/W	P/S/L	0x00
23:22	Reserved	N/A	R	N/A	0x00
20	RMWEN	RMW Enable	R/W	P/S/L	0x00
19:17	Reserved	N/A	R	N/A	0x00
16	A64DS	A64 Data Strokes	R/W	P/S/L	0x00
15	Reserved	N/A	R	N/A	0x00
14:12	VTOFF	VME Master Time Off	R/W	P/S/L	0x00
11	Reserved	N/A	R	N/A	0x00

VME Master Control Register

Bits	Name	Function	PCFS Space Type	Reset By	Reset Value
10:8	VTON	VME Master Time On	R/W	P/S/L	0x00
7:5	Reserved	N/A	R	N/A	0x00
4:3	VREL	VME Master Release Mode	R/W	P/S/L	0x00
2	VFAIR	VME Master Fair Mode	R/W	P/S/L	0x00
1:0	VREQL	VME Master Request Level	R/W	P/S/L	11b

VSA (VMEbus Stop Acknowledge): When this bit is set, the VME Master has obtained mastership of the VMEbus in response to the VS request. This bit is not set if the VME Master has obtained VMEbus ownership for any other reason.

VS (VMEbus Stop): When this bit is set, the Tsi148 requests the VMEbus. When VMEbus ownership has been obtained, the VSA bit is set. VMEbus ownership is maintained until the VS bit is cleared. While the VS bit is set, the PCI/X to VMEbus channel and DMA controllers are prevented for accessing the VMEbus. This bit is used to ensure that the VMEbus is idle before the LRESET bit is set. This bit is cleared and the VMEbus released when the LRSTI_ signal is received.

DHB (Device Has Bus): When this bit is set, the VME Master has obtained mastership of the VMEbus in response to the DWB request. This bit is not set if the VME Master has obtained VMEbus ownership for any other reason.

DWB (Device Wants Bus): When this bit is set, the VME Master requests the VMEbus. When VMEbus ownership has been obtained, the DHB bit is set. VMEbus ownership is maintained until the DWB bit is cleared. While the DWB bit is set, the PCI/X to VMEbus channel and DMA controllers may access the VMEbus.

RMWEN (RMW Enable): If set, the VME Master RMW function is enabled. If cleared, the VME Master RMW function is disabled.

A64DS (A64 Data Strokes): If set, the VME Master asserts both the DS0_ and DS1_ signals during an A64 address phase. If cleared, the VME Master asserts the data strobes based on the following data phase.

VTOFF (VME Master Time Off): These bits define the time the VME Master must wait before re-requesting the VMEbus.

Table 76: VME Master Time Off

VTOFF	Time
000b	0 μ s
001b	1 μ s
010b	2 μ s
011b	4 μ s
100b	8 μ s
101b	16 μ s
110b	32 μ s
111b	64 μ s

VTON (VME Master Time On): These bits define the time the VME Master is allowed to spend on the VMEbus. The time on timer is defined in microseconds for the SCT, BLT and MBLT protocols. The time on timer is defined in bytes for the 2eVME and 2eSST protocols. Once the Tsi148 VME Master satisfies VTON it can then access the VMEbus again based on the value programmed for VTOFF.

Table 77: VME Master Time On

VTON	Time	Count
000b	4 μ s	128 Bytes
001b	8 μ s	128 Bytes
010b	16 μ s	128 Bytes
011b	32 μ s	256 Bytes
100b	64 μ s	512 Bytes
101b	128 μ s	1024 Bytes
110b	256 μ s	2048 Bytes
111b	512 μ s	4096 Bytes

VREL (VME Master Release Mode): These bits define the VMEbus release modes for the VMEbus interface.

Table 78: VME Master Release Mode

VREL	MODE
00b	TIME ON or DONE
01b	(TIME ON and REQ) or DONE
10b	(TIME ON and BCLR) or DONE
11b	(TIME ON or DONE) and REQ

VFAIR (VME Master Fair Mode): If set, the VMEbus requester operates in fair mode. If cleared, the VMEbus requester operates in normal mode.

VREQL (VME Master Request Level): These bits define the VMEbus request level for the VME Master.

10.4.34 VMEbus Control Register

Table 79: VMEbus Control Register

Register Name: VCTRL Reset Value: 0x00000000	Register Offset: CRG + 0x238
---	-------------------------------------

Bits	7	6	5	4	3	2	1	0
31:24	Reserved				DLT			
23:16	Reserved			NELBB	Reserved		SRESET	LRESET
15:8	SFAILAI	Reserved		BID				
7:0	ATOEN	ROBIN	Reserved		GTO			

VMEbus Control Register

Bits	Name	Function	PCFS Space Type	Reset By	Reset Value
31	Reserved	N/A	R/W	N/A	0x00
30:28	Reserved	N/A	R	N/A	0x00
27:24	DLT	Deadlock Timer	R/W	P/S/L	0x00
23:21	Reserved	N/A	R	N/A	0x00
20	NELBB	No Early Release of Bus Busy	R/W	P/S	0x00
19:18	Reserved	N/A	R	N/A	0x00
17	SRESET	System Reset	S	-	0x00
16	LRESET	Local Reset	S	-	0x00
15	SFAILAI	System Fail Auto Slot ID	R/W	P/S	0xxx
14:13	Reserved	N/A	R	N/A	0x00
12:8	BID	Broadcast ID	R/W	P/S/L	0x00
7	ATOEN	Arbiter Time-out Enable	R/W	P/S	0x00
6	ROBIN	Round Robin Mode	R/W	P/S	0x00
5:4	Reserved	N/A	R	N/A	0x00
3:0	GTO	VMEbus Global Time-out	R/W	P/S	4'b1000

DLT (Deadlock Timer): These bits define the time the VME Slave waits after detecting a potential deadlock before asserting the `RETRYO_` signal.



The timer checks only for a potential deadlock. The deadlock condition it monitors is when the Tsi148's PCI/X to VME write buffers are completely full and a VMEbus initiator attempts a read to a PCI/X target through the Tsi148. This is the only potential deadlock condition this timer monitors.

Table 80: Deadlock Timer

DLT	Time
0000b	Deadlock Retry Disabled
0001b	16 VCLKs ^a
0010b	32 VCLKs
0011b	64 VCLKs
0100b	128 VCLKs
0101b	256 VCLKs
0110b	512 VCLKs
0111b	1024 VCLKs
1000b	2048 VCLKs
1001b	4096 VCLKs
1010b	8192 VCLKs
1011b	16384 VCLKs
1100b	32768 VCLKs
1101b	Reserved
1110b	Reserved
1111b	Reserved

a. A VCLK is a Tsi148 internal clock which is a 133 MHz clock.

NELBB (No Early Release of Bus Busy): When this bit is set, the Tsi148 asserts `BBSYO_` whenever `ASI_` is asserted. This disables the early release of bus busy function for all VMEbus masters. This can sometimes help debug systems when noise is causing arbitration problems.

SRESET (System Reset): When this bit is set, the SRSTO signal is asserted. This bit is automatically cleared if SRSTI is connected to SRSTO through a transceiver.

LRESET (Local Reset): When this bit is set, the LRSTO_ signal is asserted. This bit is automatically cleared. Before this bit is set, the software should set the VS bit and wait for the VSA bit to be set.

SFAILAI (SYSFAIL Auto Slot ID): When this bit is set, the SFAILO signal is asserted. When this bit is cleared, the SFAILO signal is negated. When the Auto Slot ID function is enabled, this bit is set by SRSTI_. It is cleared automatically when the auto clear mode is selected. Otherwise it is cleared by software.

BID (Broadcast ID): This field defines the broadcast ID which is used to receive 2eSST broadcast transfers. This field is compared with the broadcast slave select bits which are transmitted during address phase three of a 2eSST transfer. A value of one corresponds to address bit one set, a value of two corresponds to address bit two set and so on through a value of 21. If this field is zero, the VME Slave does not respond to a 2eSST broadcast transfer.

ATOEN (Arbiter Time-out Enable): When this bit is set, the VMEbus arbiter time-out function is enabled. When the time-out function is enabled, the arbiter asserts BBSY* if a bus grant out signal remains asserted for 16 microseconds. This causes the arbiter to re-arbitrate.

ROBIN (Round Robin): When this bit is set, the VMEbus arbiter operates in round robin mode. When this bit is cleared, the VMEbus arbiter operates in priority mode. This bit may be set or cleared at any time.

GTO (VMEbus Global Time-out): These bits define the VMEbus Global Time-out period.

Table 81: VMEbus Global Time-out

GTO	Time
0000b	8 μ s
0001b	16 μ s
0010b	32 μ s
0011b	64 μ s
0100b	128 μ s
0101b	256 μ s
0110b	512 μ s
0111b	1024 μ s
1000b	2048 μ s

Table 81: VMEbus Global Time-out

GTO	Time
1001b	Reserved
1010b	Reserved
1011b	Reserved
1100b	Reserved
1101b	Reserved
1110b	Reserved
1111b	Disabled

10.4.35 VMEbus Status Register

Table 82: VMEbus Status Register

Register Name: VSTAT Reset Value: 0x				Register Offset: CRG + 0x23C				
Bits	7	6	5	4	3	2	1	0
31:24	Reserved							
23:16	Reserved							
15:8	CPURST	BDFAIL	Reserved	PURSTS	BDFAILS	SYSFLS	ACFAILS	SCONS
7:0	Reserved		GAP	GA				

VME Master Control Register

Bits	Name	Function	PCFS Space Type	Reset By	Reset Value
31:16	Reserved	N/A	R	N/A	0x00
15	CPURST	Clear Power Up Reset	C	N/A	0x00
14	BDFAIL	Board Fail	R/W	P/S/L	0x01
13	Reserved	N/A	R	N/A	0x00
12	PURSTS	Power Up Reset Status	R	P	0x01
11	BDFAILS	Board Fail Status	R	N/A	0x01
10	SYSFLS	System Fail Status	R	N/A	0xxx
9	ACFAILS	AC Fail Status	R	N/A	0xxx
8	SCONS	System Controller Status	R	P	0xxx
7:6	Reserved	N/A	R	N/A	0x00
5	GAP	Geographic Address Parity	R		0xxx
4:0	GA	Geographic Address	R	N/A	0xxx

CPURST (Clear Power Up Reset): When this bit is set, the PURSTS bit is cleared. This bit always returns zero when read.

BDFAIL (Board Fail): This is the board fail control bit. When this bit is high, the BDFAIL_ signal is asserted by the Tsi148. When this bit is low, the BDFAIL_ signal is not asserted by the Tsi148. Board fail is set by a local bus reset and is cleared by software when the board is ready.

PURSTS (Power Up Reset Status): This bit is set when the PURSTI_ signal is asserted. It can be cleared by setting the CPURST bit.

BDFAILS (Board Fail Status): This is the board fail status bit. When this bit is high, the BDFAIL_ signal is asserted. When this bit is low, the BDFAIL_ signal is negated.

SYSFLS (System Fail Status): This bit indicates the current state of the SFAILI_ signal. When this bit is high, the SFAILI_ signal is asserted. When this bit is low, the SFAILI_ signal is negated.

ACFAILS (AC Fail Status): This bit indicates the current state of the ACFAILI_ signal. When this bit is high, the ACFAILI_ signal is asserted. When this bit is low, the ACFAILI_ signal is negated.

SCONS (System Controller Status): When this bit is high, the VMEbus system controller is enabled. When this bit is low, the VMEbus system controller is not enabled.

GAP (Geographic Address Parity): This bit is the parity bit for the Geographic Address. This bit is inverted from the VMEbus GAP_ signal.

GA (Geographic Address): These bits represent the Geographic Address of the board. These bits are inverted from the VMEbus GA[4:0]_ signals.

10.4.36 PCI/X Control / Status Register

The PCI/X Control Status Register (PCSR) contains the PCI/X bus configuration information captured from the PCI/X bus on the rising edge of the LRSTI_ signal. This information is used to define the mode, clock frequency and bus width.

Table 83: PCI/X Control / Status Register

Register Name: PCSR Reset Value: 0x					Register Offset: CRG + 0x240			
Bits	7	6	5	4	3	2	1	0
31:24	Reserved					SRTO		
23:16	Reserved	SRTT	CCTM	DRQ	DTTT	MRCT	MRC	SBH
15:8	Reserved					SRTE	DTTE	MRCE
7:0	Reserved	REQ64S	M66ENS	FRAMES	IRDYS	DEVSELS	STOPS	TRDYS

PCI/X Control / Status Register

Bits	Name	Function	PCFS Space Type	Reset By	Reset Value
31:27	Reserved	N/A	R	N/A	0x00
26:24	SRTO	PCI-X Split Response Time-out	R/W	P/S/L	111b
23	Reserved	N/A	R	N/A	0x00
22	SRTTS	Split Response Time-out Test	R/W	P/S/L	0x00
21	CCTM	Configuration Cycle Test Mode	R/W	P/S/L	0x00
20	DRQ	Disregard REQ64_ Qualification	R/W	P/S/L	0x00
19	DTTT	Delayed Transaction Time-out Test	R/W	P/S/L	0x00
18	MRCT	Maximum Retry Count Test	R/W	P/S/L	0x00
17	MRC	Maximum Retry Count	R/W	P/S/L	0x00
16	SBH	Stop on Byte Holes	R/W	P/S/L	0x00
15:11	Reserved	N/A	R	N/A	0x00
10	SRTE	Split Response Time-out Error	R/C	P/S/L	0x00
9	DTTE	Delayed Transaction Time-out Error	R/C	P/S/L	0x00

PCI/X Control / Status Register

Bits	Name	Function	PCFS Space Type	Reset By	Reset Value
8	MRCE	Maximum Retry Count Error	R/C	P/S/L	0x00
7	Reserved	N/A	R	N/A	0x00
6	REQ64S	REQ64 Status	R	P/S/L	0xxx
5	M66ENS	66 MHz enable Status	R	P/S/L	0xxx
4	FRAMES	FRAME Status	R	P/S/L	0xxx
3	IRDYS	IRDY Status	R	P/S/L	0xxx
2	DEVSELS	DEVSEL Status	R	P/S/L	0xxx
1	STOPS	STOP Status	R	P/S/L	0xxx
0	TRSDYS	TRDY Status	R	P/S/L	0xxx

SRTO (PCI-X Split Response Time-out): These bits define the PCI-X Split Response Time-out period. The Split Response Time-out should be set to a time that is longer than the VMEbus global time-out time. The VMEbus Global time-out timer is a VMEbus system controller function may be controlled by another device.

Table 84: PCI-X Split Read Time-out

SRTO	Time
000b	16 μ s
001b	32 μ s
010b	64 μ s
011b	128 μ s
100b	256 μ s
101b	512 μ s
110b	1024 μ s
111b	Disabled

SRTT (Split Response Time-out Test): When this bit is set, the split response time-out time is reduced for test purposes. Only single beat transfers are supported. When this bit is cleared, the split response time-out time is controlled by the SRTO field. This bit is provided for test purposes.

CCTM (Configuration Cycle Test Mode): When this bit is set, any VME to PCI/X cycle that uses inbound map decoder number 7 generates PCI/X configuration read and write cycles. Only single beat transfers are supported. When this bit is cleared, inbound map decoder 7 behaves normally. This bit is provided for test purposes.

DRQ (Disregard REQ64_ Qualification): This bit must be cleared to comply with the *PCI Local Bus Specification (Revision 2.2)*.

DTTT (Delayed Transaction Time-out Test): When this bit is set, a delayed transaction times-out after 160 PCI/X bus clocks. When this bit is cleared, a delayed transaction times-out after 2^{15} clocks. This bit reduces the time-out count for test purposes.

MRCT (Maximum Retry Count Test): When this bit is set and the MRC bit is set, the PCI/X Master retries 16 times before indicating an error. When this bit is cleared and the MRC bit is set, the PCI/X Master retries 2^{24} times before indicating an error. This bit reduces the retry count for test purposes.



This bit should be cleared to comply with the *PCI Local Bus Specification (Revision 2.2)*.

MRC (Maximum Retry Count): When this bit is set, the PCI/X Master counts the number of sequential cycles that are retried. If the count is exceeded, the PCI/X Master aborts the transfer. When this bit is cleared, there is no limit to the number of retry attempts.

SBH (Stop on Byte Holes): When this bit is set and the PCI/X bus is configured for conventional mode, the PCI Target issues a stop command when a transfer has non contiguous byte enables. When this bit is clear, the PCI Target issues multiple linkage commands to handle transfers with non contiguous byte enables. This bit is provided for diagnostic purposes.

SRTE (Split Response Time-out Error): This bit is set when a split response time-out error occurs. This bit is cleared by writing a one to this bit.

DTTE (Delayed Transaction Time-out Error): This bit is set when a delayed transaction time-out error occurs. This bit is cleared by writing a one to this bit.

MRCE (Maximum Retry Count Error): This bit is set when the MRC bit is set and the maximum number of retries is exceeded. This bit is cleared by writing a one to this bit.

REQ64S (REQ64 Status): When this bit is set, the REQ64_ signal was sampled high at the rising edge of LRSTI_ and the PCI/X A/D bus is configured for 32-bit. When this bit is clear, the REQ64_ signal was sampled low at the rising edge of reset and the PCI/X A/D bus is configured for 64-bit operation.

M66ENS (66 MHz Enable Status): When this bit is set, the M66EN signal was sampled high at the rising edge of LRSTI_. When this bit is clear, the M66EN signal was sampled low at the rising edge of LRSTI_.

FRAMES (FRAME Status): When this bit is set, the FRAME_ signal was sampled high at the rising edge of LRSTI_. When this bit is clear, the FRAME_ signal was sampled low at the rising edge of LRSTI_.

IRDYS (IRDY Status): When this bit is set, the IRDY_ signal was sampled high at the rising edge of LRSTI_. When this bit is clear, the IRDY_ signal was sampled low at the rising edge of LRSTI_.

DEVSELS (DEVSEL Status): When this bit is set, the DEVSEL_ signal was sampled high at the rising edge of LRSTI_. When this bit is clear, the DEVSEL_ signal was sampled low at the rising edge of LRSTI_.

STOPS (STOP Status): When this bit is set, the STOP_ signal was sampled high at the rising edge of LRSTI_. When this bit is clear, the STOP_ signal was sampled low at the rising edge of LRSTI_.

TRDYS (TRDY Status): When this bit is set, the TRDY_ signal was sampled high at the rising edge of LRSTI_. When this bit is clear, the TRDY_ signal was sampled low at the rising edge of LRSTI_.

10.4.37 VMEbus Filter Register.

Table 85: PCI/X Control / Status Register

Register Name: VMEFL Reset Value: 0x	Register Offset: CRG + 0x250
---	-------------------------------------

Bits	7	6	5	4	3	2	1	0
31:24	Reserved						ACKD	
23:16	Reserved							
15:8	Reserved				BGFC	BRFC	BCFC	BBFC
7:0	Reserved			AKFC	Reserved			STFC

PCI/X Control / Status Register

Bits	Name	Function	PCFS Space Type	Reset By	Reset Value
31:26	Reserved	N/A	R	N/A	0x00
25:24	ACKD	Acknowledge Delay	R/W	P	10b
23:12	Reserved	N/A	R	N/A	0x00
11	BGFC	Bus Grant Filter Control	R/W	P	0x01
10	BRFC	Bus Request Filter Control	R/W	P	0x01
9	BCFC	Bus Clear Filter Control	R/W	P	0x01
8	BBFC	Bus Busy Filter Control	R/W	P	0x01
7:5	Reserved	N/A	R	N/A	0x00
4	AKFC	Acknowledge Filter Control	R/W	P	0x00
3:1	Reserved	N/A	R	N/A	0x00
0	STFC	Strobe Filter Control	R/W	P	0x00

ACKD (Acknowledge Delay): These bits define the delay time from when the VMEbus data strobes are negated until the acknowledge signals (DTACKO_, BERRO_, and RETRYO_)

are negated.

Table 86: Acknowledge Delay Time

ACKD	Time
00b	Slow
01b	Medium
10b	Fast
11b	Reserved

BGFC (Bus Grant Filter Control): When this bit is set, the VMEbus BG[3:0]IN_ and IACKIN_ signals are filtered with a digital filter to remove noise and glitches. When this bit is clear, the VMEbus BGIN[3:0]_ and IACKIN_ signals are not filtered.

BRFC (Bus Request Filter Control): When this bit is set, the VMEbus BR[3:0]I_ signals are filtered with a digital filter to remove noise and glitches. When this bit is clear, the VMEbus BR[3:0]I_ signals are not filtered.

BCFC (Bus Clear Filter Control): When this bit is set, the VMEbus BCLRI_ signal is filtered with a digital filter to remove noise and glitches. When this bit is clear, the VMEbus BCLRI_ signal is not filtered.

BBFC (Bus Busy Filter Control): When this bit is set, the VMEbus BBSYI_ signal is filtered with a digital filter to remove noise and glitches. When this bit is clear, the VMEbus BBSYI_ signal is not filtered.

AKFC (Acknowledge Filter Control): When this bit is set, filtering is applied to the VMEbus acknowledge signals (DTACKI_, BERRI_, and RETRYI_). When this bit cleared, no filtering is applied to the VMEbus acknowledge signals.

STFC (Strobe Filter Control): When this bit is set, filtering is applied to the VMEbus strobe signals (ASL_, DS0I_, and DS1I_). When this bit cleared, no filtering is applied to the VMEbus strobe signals.

10.4.38 VMEbus Exception Address Upper Register

This register captures VMEbus address bits 63 to 32 whenever the Tsi148 is VME Master and a VMEbus exception occurs. This register is only updated when the VES bit in the VMEbus Exception Attributes register is clear.

Table 87: VMEbus Exception Address Upper Register

Register Name: VEAU Reset Value: 0x00000000	Register Offset: CRG + 0x260
--	-------------------------------------

Bits	7	6	5	4	3	2	1	0
31:0	VEAU							

VMEbus Exception Address Upper Register

Bits	Name	Function	PCFS Space Type	Reset By	Reset Value
31:0	VEAU	VMEbus Exception Address Upper	R	P/S/L	0x00

10.4.39 VMEbus Exception Address Lower Register

This register captures VMEbus address bits 31 to 1 whenever the Tsi148 is VME Master and a VMEbus exception occurs. This register is only updated when the VES bit in the VMEbus Exception Attributes register is clear.

Table 88: VMEbus Exception Address Lower Register

Register Name: VEAL Reset Value: 0x00000000	Register Offset: CRG + 0x264
--	-------------------------------------

Bits	7	6	5	4	3	2	1	0
31:0	VEAL							

VMEbus Exception Address Lower Register

Bits	Name	Function	PCFS Space Type	Reset By	Reset Value
31:0	VEAL	VMEbus Exception Address Lower	R	P/S/L	0x00

10.4.40 VMEbus Exception Attributes Register

Table 89: VMEbus Exception Attributes Register

Register Name: VEAT Reset Value: 0x				Register Offset: CRG + 0x268				
Bits	7	6	5	4	3	2	1	0
31:24	VES	VEOF	VESCL	Reserved				
23:16	Reserved		2eOT	2eST	BERR	LWORD	WRITE	IACK
15:8	DS1	DS0	AM					
7:0	XAM							

PCI/X Control / Status Register

Bits	Name	Function	PCFS Space Type	Reset By	Reset Value
31	VES	VMEbus Exception Status	R	P/S/L	0x00
30	VEOF	VMEbus Exception Overflow	R	P/S/L	0x00
29	VESCL	VMEbus Exception Status Clear	C	P/S/L	0x00
28:22	Reserved	N/A	R	N/A	0x00
21	2eOT	2e Odd Termination	R	P/S/L	0x10
20	2eST	2e Slave Terminated	R	P/S/L	0x00
19	BERR	VMEbus Error	R	P/S/L	0x00
18	LWORD	LWORD	R	P/S/L	0x00
17	WRITE	WRITE	R	P/S/L	0x00
16	IACK	IACK	R	P/S/L	0x00
15	DS1	DS1	R	P/S/L	0x00
14	DS0	DS0	R	P/S/L	0x00
13:8	AM	AM	R	P/S/L	0x00
7:0	XAM	XAM	R	P/S/L	0x00

VES (VMEbus Exception Status): This bit is set when the VMEbus exception registers are updated. The VMEbus error diagnostic registers are updated when the VES bit is clear and the a VMEbus master transfer is terminated with an error condition, a 2eVME transfer is terminated by the slave or 2eSST transfer is terminated with the last word invalid. If an exception occurs and the VES bit is set, then the current status is retained and the VEOF bit is set. This bit is cleared by writing a one to the VESCL bit.

VEOF (VMEbus Exception Overflow): If the VES bit is clear and a VMEbus exception occurs, the VMEbus error diagnostic registers capture the VMEbus address and attributes. If another error occurs and the VES bit is set, then the VEOF bit is set and the registers are not updated. The VEOF and VES bits are cleared by writing a one to the VESCL bit.

VESCL (VMEbus Exception Status Clear): When this bit is set, the VES and VEOF bits are cleared. This bit always reads zero and writing a zero has no effect.

2eOT (2e Odd Termination): This bit is set when the error diagnostic registers are updated because a 2eSST transfer was terminated with a last word invalid exception. This bit is also set when a 2eVME transfer receives a slave termination or error termination on an odd beat. This bit is only updated when the VES bit is clear.

2eST (2e Slave Terminated): This bit is set when the error diagnostic registers are updated because a 2eVME or 2eSST transfer was terminated by the slave. This bit is only updated when the VES bit is clear.

BERR (VMEbus Error): This bit is set when the error diagnostic registers are updated because a VMEbus transfer was terminated with an error. This bit is only updated when the VES bit is clear.

LWORD (LWORD): This bit captures the state of the VMEbus LWORD_ signal when the Tsi148 is VME Master and an exception occurs. This bit is set when the LWORD_ signal is asserted. This bit is only updated when the VES bit is clear.

WRITE (WRITE): This bit captures the state of the VMEbus WRITE_ signal when the Tsi148 is VME Master and an exception occurs. This bit is set when the WRITEI_ signal is asserted. This bit is only updated when the VES bit is clear.

IACK (IACK): This bit captures the state of the VMEbus IACK_ signal when the Tsi148 is VME Master and an exception occurs. This bit is set when the IACK_ signal is asserted. This bit is only updated when the VES bit is clear.

DS1 (DS1): This bit captures the state of the VMEbus DS1_ signal when the Tsi148 is VME Master and an exception occurs. This bit is set when the DS1I_ signal is asserted. This bit is only updated when the VES bit is clear.

DS0 (DS0): This bit captures the state of the VMEbus DS0_ signal when the Tsi148 is VME Master and an exception occurs. This bit is set when the DS0I_ signal is asserted. This bit is only updated when the VES bit is clear.

AM (AM): These bits capture the state of the VMEbus AM signals when the Tsi148 is VME Master and an exception occurs. These bits are only updated when the VES bit is clear.

XAM (XAM): These bits captures the state of the VMEbus XAM signals when the Tsi148 is VME Master and an exception occurs. These bits are only updated when the VES bit is clear.

10.4.41 Error Diagnostic PCI/X Address Upper Register

This register captures PCI/X bus address bits 63 to 32 whenever PCI/X bus error occurs. This register is only updated when the EDPST bit in the Error Diagnostic PCI/X Attributes register is clear.

Table 90: Error Diagnostic PCI/X Address Upper Register

Register Name: EDPAU Reset Value: 0x00000000	Register Offset: CRG + 0x270
---	-------------------------------------

Bits	7	6	5	4	3	2	1	0
31:0	EDPAU							

Error Diagnostic PCI/X Address Upper Register

Bits	Name	Function	PCFS Space Type	Reset By	Reset Value
31:0	EDPAU	Error Diagnostic PCI/X Address Upper	R	P/S/L	0x00

10.4.42 Error Diagnostic PCI/X Address Lower Register

This register captures PCI/X address bits 31 to 0 whenever a PCI/X bus error occurs. This register is only updated when the EDPST bit in the Error Diagnostic PCI/X Attributes register is clear.

Table 91: Error Diagnostic PCI/X Address Lower Register

Register Name: EDPAL Reset Value: 0x00000000	Register Offset: CRG + 0x274
---	-------------------------------------

Bits	7	6	5	4	3	2	1	0
31:0	EDPAL							

Error Diagnostic PCI/X Address Lower Register

Bits	Name	Function	PCFS Space Type	Reset By	Reset Value
31:0	EDPAL	Error Diagnostic PCI/X Address Lower	R	P/S/L	0x00

10.4.43 Error Diagnostic PCI-X Attribute Register

This register captures the PCI-X bus AD bits 31 to 0 during the attribute phase whenever a PCI-X bus error occurs. This register is only updated when the EDPST bit is clear.

Table 92: Error Diagnostic PCI-X Attribute Register

Register Name: EDPXA Reset Value: 0x00000000				Register Offset: CRG + 0x278				
Bits	7	6	5	4	3	2	1	0
31:0	EDPXA							

Error Diagnostic PCI-X Attribute Register

Bits	Name	Function	PCFS Space Type	Reset By	Reset Value
31:0	EDPXA	Error Diagnostic PCI-X Attribute	R	P/S/L	0x00

10.4.44 Error Diagnostic PCI-X Split Completion Message Register

This register captures the PCI-X bus split completion message whenever a PCI-X bus error occurs. This register is only updated when the EDPST bit in the Error Diagnostic PCI-X Attributes register is clear.

Table 93: Error Diagnostic PCI-X Split Completion Message Register

Register Name: EDPXS Reset Value: 0x00000000	Register Offset: CRG + 0x27C
---	-------------------------------------

Bits	7	6	5	4	3	2	1	0
31:0	EDPXS							

Error Diagnostic PCI-X Split Completion Message Register

Bits	Name	Function	PCFS Space Type	Reset By	Reset Value
31:0	EDPXS	Error Diagnostic PCI-X Split Completion Message	R	P/S/L	0x00

10.4.45 Error Diagnostic PCI/X Attributes Register

Table 94: Error Diagnostic PCI/X Attributes Register

Register Name: EDPAT Reset Value: 0x00000000	Register Offset: CRG + 0x280
---	-------------------------------------

Bits	7	6	5	4	3	2	1	0
31:24	EDPST	EDPOF	EDPCL	Reserved				
23:16	Reserved						SCD	USC
15:8	SRT	SCEM	DPED	DPE	MRC	RMA	RTA	DTT
7:0	CBEA3	CBEA2	CBEA1	CBEA0	COMM3	COMM2	COMM1	COMM0

Error Diagnostic PCI/X Attributes Register

Bits	Name	Function	PCFS Space Type	Reset By	Reset Value
31	EDPST	Error Diagnostic PCI/X Status	R	P/S/L	0x00
30	EDPOF	Error Diagnostic PCI/X Overflow	R	P/S/L	0x00
29	EDPCL	Error Diagnostic PCI/X Clear	C	P/S/L	0x00
28:18	Reserved	N/A	R	N/A	0x00
17	SCD	Split Completion Discarded.	R	P/S/L	0x00
16	USC	Unexpected Split Completion	R	P/S/L	0x00
15	SRT	Split Response Time-out	R	P/S/L	0x00
14	SCEM	Split Completion Error Message	R	P/S/L	0x00
13	DPED	Data Parity Error Detected.	R	P/S/L	0x00
12	DPE	Detected Parity Error	R	P/S/L	0x00
11	MRC	Maximum Retry Count	R	P/S/L	0x00
10	RMA	Received Master Abort	R	P/S/L	0x00
9	RTA	Received Target Abort	R	P/S/L	0x00
8	DTT	Delayed Transaction Time-out	R	P/S/L	0x00
7:4	CBEAx	CBE Attribute	R	P/S/L	0x00

Error Diagnostic PCI/X Attributes Register

Bits	Name	Function	PCFS Space Type	Reset By	Reset Value
3:0	COMMx	Command	R	P/S/L	0x00

EDPST (Error Diagnostic PCI/X Status): This bit is set when the PCI/X bus error diagnostic registers are updated. This bit is cleared by writing a one to the EDPCL bit.

EDPOF (Error Diagnostic PCI/X Overflow): If the EDPST bit is clear and a PCI/X bus error occurs, the PCI/X bus error diagnostic registers capture the PCI/X bus address and attributes. If another error occurs and the EDPST is set, then the EDPOF bit is set and the registers are not updated. The EDPOF bit is cleared by writing a one to the EDPCL bit.

EDPCL (Error Diagnostic PCI/X Clear): When this bit is set, all bits in the EDPAU, EDPAL and EDPAT registers are cleared. This bit always read zero and writing a zero has no effect.

SCD (Split Completion Discarded): This bit is set when a split completion is discarded. This bit is only updated when the EDPST bit is clear.

USC (Unexpected Split Completion): This bit is set when an unexpected split completion is received. This bit is only updated when the EDPST bit is clear.

SRT (Split Response Time-out): This bit is set when a split response time-out occurs. This bit is only updated when the EDPST bit is clear.

SCEM (Split Completion Error Message): This bit is set when a split completion error message is received. This bit is only updated when the EDPST bit is clear.

DPED (Data Parity Error Detected): This bit is set when three conditions are met: 1) the Tsi148 asserted PERR_ itself or observed PERR_ asserted; 2) the Tsi148 was the PCI/X Master for the transfer in which the error occurred; 3) the PERR bit in the CMMD register is set. This bit is only updated when the EDPST bit is clear.

DPE (Detected Parity Error): This bit is set when the PCI/X Master detects a data parity error during a read transaction or the PCI/X Target detects a parity error during a write transaction. This bit is only updated when the EDPST bit is clear.

MRC (Maximum Retry Count): This bit is set when the maximum retry count is exceeded. This bit is only updated when the EDPST bit is clear.

RMA (Received Master Abort): This bit is set when the master receives a master abort. This bit is only updated when the EDPST bit is clear.

RTA (Received Target Abort): This bit is set when the master receives a target abort. This bit is only updated when the EDPST bit is clear.

DTT (Delayed Transaction Time-out): This bit is set when there is a delayed transaction time-out. This bit is only updated when the EDPST bit is clear.

CBEAx (CBE Attribute): These bits capture the PCI-X bus CBE signals during the attribute phase whenever a PCI/X bus error occurs. These bits are only updated when the EDPST bit is clear.

COMMx (Command): These bits capture the PCI/X bus command whenever a PCI/X bus error occurs. These bits are only updated when the EDPST bit is clear.

10.4.46 Inbound Translation Starting Address Upper (0-7) Registers

The Inbound Translation Starting Address Upper Registers (ITSAU0-ITSAU7) contain address information associated with the mapping of VMEbus space to PCI/X space. The Inbound VMEbus address is decoded when the VMEbus address is greater than or equal to the start address and less than or equal to the end address.

Table 95: Inbound Translation Starting Address Upper (0-7) Register

Register Name: ITSAUx Reset Value: 0x00000000		Register Offset: ITSAU0: CRG + 0x300 ITSAU1: CRG + 0x320 ITSAU2: CRG + 0x340 ITSAU3: CRG + 0x360 ITSAU4: CRG + 0x380 ITSAU5: CRG + 0x3A0 ITSAU6: CRG + 0x3C0 ITSAU7: CRG + 0x3E0						
Bits	7	6	5	4	3	2	1	0
31:0	STAU							

Inbound Translation Starting Address Upper (0-7) Register

Bits	Name	Function	PCFS Space Type	Reset By	Reset Value
31:0	STAU	Start Address Upper	R/W	P/S/L	0x00

STAU (Start Address Upper): This field determines the start address of a particular area on the VMEbus which is used to access local resources. The value of this field is compared with the incoming VMEbus address. If the VMEbus address is 64-bit, then the start address upper is compared with VMEbus address bit 63 to 32. This field is only used when the VMEbus address is 64-bits.

10.4.47 Inbound Translation Starting Address Lower (0-7) Registers

The Inbound Translation Starting Address Lower Registers (ITSAL0-ITSAL7) contain address information associated with the mapping of VMEbus space to PCI/X space. The inbound VMEbus address is decoded when the VMEbus address is greater than or equal to the start address and less than or equal to the end address.

Table 96: Inbound Translation Starting Address Upper (0-7) Register

Register Name: ITSALx Reset Value: 0x00000000	Register Offset: ITSAL0: CRG + 0x304 ITSAL1: CRG + 0x324 ITSAL2: CRG + 0x344 ITSAL3: CRG + 0x364 ITSAL4: CRG + 0x384 ITSAL5: CRG + 0x3A4 ITSAL6: CRG + 0x3C4 ITSAL7: CRG + 0x3E4
--	--

Bits	7	6	5	4	3	2	1	0
31:24	STAL							
23:16	STAL							
15:8	STAL							
7:0	STAL				Reserved			

Inbound Translation Starting Address Lower (0-7) Register

Bits	Name	Function	PCFS Space Type	Reset By	Reset Value
31:4	STAL	Start Address Lower	R/W	P/S/L	0x00
3:0	Reserved	N/A	R	N/A	0x00

STAL (Start Address Lower): If the VMEbus address bus is 64-bit or 32-bit, then the start address lower bits 31 to 16 are compared with VMEbus address bits 31 to 16 and the granularity is 64 Kbytes. If the VMEbus address is 24-bits, then the start address lower bits 23 to 12 are compared with VMEbus address bits 23 to 12 and the granularity is 4 Kbytes. If the VMEbus address is 16-bits, then the start address lower bits 15 to 4 are compared with VMEbus address bits 15 to 4 and the granularity is 16 bytes.

10.4.48 Inbound Translation Ending Address Upper (0-7) Registers

The Inbound Translation Ending Address Upper Registers (ITEAU0-ITEAU7) contain address information associated with the mapping of VMEbus space to PCI/X space. The Inbound VMEbus address is decoded when the VMEbus address is greater than or equal to the start address and less than or equal to the end address.

Table 97: Inbound Translation Ending Address Upper (0-7) Register

Register Name: ITEAUx Reset Value: 0x00000000				Register Offset: ITEAU0: CRG + 0x308 ITEAU1: CRG + 0x328 ITEAU2: CRG + 0x348 ITEAU3: CRG + 0x368 ITEAU4: CRG + 0x388 ITEAU5: CRG + 0x3A8 ITEAU6: CRG + 0x3C8 ITEAU7: CRG + 0x3E8				
Bits	7	6	5	4	3	2	1	0
31:0	ENDU							

Inbound Translation Ending Address Upper (0-7) Register

Bits	Name	Function	PCFS Space Type	Reset By	Reset Value
31:0	ENDU	End Address Upper	R/W	P/S/L	0x00

ENDU (End Address Upper): This field determines the end address of a particular area on the VMEbus which is used to access local resources. The value of this field is compared with the incoming VMEbus address. If the VMEbus address is 64-bit, then the end address upper is compared with VMEbus address bit 63 to 32. This field is only used when the VMEbus address is 64-bits.

10.4.49 Inbound Translation Ending Address Lower (0-7) Registers

The Inbound Translation Ending Address Lower Registers (ITEAL0-ITEAL7) contain address information associated with the mapping of VMEbus space to PCI/X space. The inbound VMEbus address is decoded when the VMEbus address is greater than or equal to the start address and less than or equal to the end address.

Table 98: Inbound Translation Ending Address Lower (0-7) Register

Register Name: IITEALx Reset Value: 0x00000000	Register Offset: ITEAL0: CRG + 0x30C ITEAL1: CRG + 0x32C ITEAL2: CRG + 0x34C ITEAL3: CRG + 0x36C ITEAL4: CRG + 0x38C ITEAL5: CRG + 0x3AC ITEAL6: CRG + 0x3CC ITEAL7: CRG + 0x3EC
---	--

Bits	7	6	5	4	3	2	1	0
31:24	ENDAL							
23:16	ENDAL							
15:8	ENDAL							
7:0	ENDAL				Reserved			

Inbound Translation Ending Address Lower (0-7) Register

Bits	Name	Function	PCFS Space Type	Reset By	Reset Value
31:4	ENDAL	Start Address Lower	R/W	P/S/L	0x00
3:0	Reserved	N/A	R	N/A	0x00

ENDL (End Address Lower): If the VMEbus address bus is 64-bit or 32-bit, then the end address lower bits 31 to 16 are compared with VMEbus address bits 31 to 16 and the granularity is 64 Kbytes. If the VMEbus address is 24-bits, then the end address lower bits 23 to 12 are compared with VMEbus address bits 23 to 12 and the granularity is 4 Kbytes. If the VMEbus address is 16-bits, then the end address lower bits 15 to 4 are compared with VMEbus address bits 15 to 4 and the granularity is 16 bytes.

10.4.50 Inbound Translation Offset Upper (0-7) Registers

The Inbound Translation Offset Upper Registers (ITOFU0-ITOFU7) contain information associated with the mapping of VMEbus space to PCI/X space.

Table 99: Inbound Translation Offset Upper (0-7) Register

Register Name: IITOFUx Reset Value: 0x00000000	Register Offset: ITOFU0: CRG + 0x310 ITOFU1: CRG + 0x330 ITOFU2: CRG + 0x350 ITOFU3: CRG + 0x370 ITOFU4: CRG + 0x390 ITOFU5: CRG + 0x3B0 ITOFU6: CRG + 0x3D0 ITOFU7: CRG + 0x3F0
---	--

Bits	7	6	5	4	3	2	1	0
31:0	OFFU							

Inbound Translation Offset Upper (0-7) Register

Bits	Name	Function	PCFS Space Type	Reset By	Reset Value
31:0	OFFU	Offset Upper	R/W	P/S/L	0x00

OFFU (Offset Upper): This field contains the offset that is added to VMEbus address bits 63 to 32 to create the PCI/X bus address. If the VMEbus address is not 64-bit, then the internal VMEbus address bits 63 to 32 are zeroed before the offset is added.

10.4.51 Inbound Translation Offset Lower (0-7) Registers

The Inbound Translation Offset Lower Registers (ITOFL0-ITOFL7) contain information associated with the mapping of VMEbus space to PCI/X space.

Table 100: Inbound Translation Offset Lower (0-7) Register

Register Name: IITOFL Reset Value: 0x00000000	Register Offset: ITOFL0: CRG + 0x314 ITOFL1: CRG + 0x334 ITOFL2: CRG + 0x354 ITOFL3: CRG + 0x374 ITOFL4: CRG + 0x394 ITOFL5: CRG + 0x3B4 ITOFL6: CRG + 0x3D4 ITOFL7: CRG + 0x3F4
--	--

Bits	7	6	5	4	3	2	1	0
31:24	OFFL							
23:16	OFFL							
15:8	OFFL							
7:0	OFFL				Reserved			

Inbound Translation Offset Lower (0-7) Register

Bits	Name	Function	PCFS Space Type	Reset By	Reset Value
31:4	OFFL	Offset Lower	R/W	P/S/L	0x00
3:0	Reserved	N/A	R	N/A	0x00

OFFL (Offset Lower): This field contains the offset that is added to the lower VMEbus address bits to create the PCI/X bus address. If the VMEbus address is 24-bit, then the internal VMEbus address bits 31 to 24 are zeroed and then offset bits 31 to 12 are added. If the VMEbus address is 16-bit, then the internal VMEbus address bits 31 to 16 are zeroed and offset bits 31 to 4 are added.

10.4.52 Inbound Translation Attribute (0-7) Registers

The Inbound Translation Attribute Registers (ITAT0-ITAT7) contain information associated with the mapping of VMEbus space to PCI/X space.

Table 101: Inbound Translation Attribute (0-7) Register

Register Name: ITATx Reset Value: 0x00000000	Register Offset: ITAT0: CRG + 0x318 ITAT1: CRG + 0x338 ITAT2: CRG + 0x358 ITAT3: CRG + 0x378 ITAT4: CRG + 0x398 ITAT5: CRG + 0x3B8 ITAT6: CRG + 0x3D8 ITAT7: CRG + 0x3F8
---	--

Bits	7	6	5	4	3	2	1	0
31:24	EN	Reserved						
23:16	Reserved					TH	VFS1	VFS0
15:8	Reserved	2eSSTM2	2eSSTM1	2eSSTM0	2eSSTB	2eSST	2eVME	MBLT
7:0	BLT	AS2	AS1	AS0	SUPR	NPRIV	PGM	DATA

Inbound Translation Attribute (0-7) Register

Bits	Name	Function	PCFS Space Type	Reset By	Reset Value
31	EN	Enable	R/W	P/S/L	0x00
30:19	Reserved	N/A	R	N/A	0x00
18	TH	Threshold	R/W	P/S/L	0x00
17	VFS1	Virtual FIFO Size	R/W	P/S/L	0x00
16	VFS0	Virtual FIFO Size	R/W	P/S/L	0x00
15	Reserved	N/A	R	N/A	0x00
14	2eSSTM2	2eSSTM	R/W	P/S/L	0x00
13	2eSSTM1	2eSSTM	R/W	P/S/L	0x00
12	2eSSTM0	2eSSTM	R/W	P/S/L	0x00
11	2eSSTB	2eSSTB	R/W	P/S/L	0x00
10	2eSST	2eSST	R/W	P/S/L	0x00

Inbound Translation Attribute (0-7) Register

Bits	Name	Function	PCFS Space Type	Reset By	Reset Value
9	2eVME	2eVME	R/W	P/S/L	0x00
8	MBLT	MBLT	R/W	P/S/L	0x00
7	BLT	BLT	R/W	P/S/L	0x00
6	AS2	Address Space	R/W	P/S/L	0x00
5	AS1	Address Space	R/W	P/S/L	0x00
4	AS0	Address Space	R/W	P/S/L	0x00
3	SUPR	Supervisor	R/W	P/S/L	0x00
2	NPRIV	Non-privileged	R/W	P/S/L	0x00
1	PGM	Program	R/W	P/S/L	0x00
0	DATA	Data	R/W	P/S/L	0x00

EN (Enable): If set, the corresponding VME Slave window is enabled.

TH (Threshold): This field sets a threshold for when read-ahead prefetching resumes. If set, prefetching resumes once the FIFO is half empty. If cleared, prefetching resumes once the FIFO is completely empty.

VFS (Virtual FIFO Size): This field is used to set the FIFO size for inbound prefetch reads. The selection of a virtual FIFO size affects the number of initial prefetch read cycles and the number of subsequent prefetch read cycles.

Table 102: Virtual FIFO Size

VFS	FIFO Size Bytes	Initial Read Bytes	Subsequent Reads Bytes
00b	64	64	32
01b	128	128	64
10b	256	256	128
11b	512	512	256

2eSSTM (2eSSTM): These bits define the 2eSST transfer rates the corresponding VME Slave responds to. If SST320 is enabled, the VME Slave also responds to SST267 and SST160. If SST267 is enabled, the VME Slave also responds to SST160.

Table 103: 2eSST Mode

2eSSTM	2eSST Mode
000b	SST160
001b	SST267
010b	SST320
011b-111b	Reserved

2eSSTB (2eSSTB): If set, the corresponding VME Slave responds to 2eSST broadcast cycles.

2eSST (2eSST): If set, the corresponding VME Slave responds to standard 2eSST cycles.

2eVME (2eVME): If set, the corresponding VME Slave responds to 2eVME cycles.

MBLT (MBLT): If set, the corresponding VME Slave responds to MBLT cycles.

BLT (BLT): If set, the corresponding VME Slave responds to BLT cycles.

AS (Address Space): These bits define the address space the corresponding VME Slave responds to.

Table 104: VMEbus Address Space

AS	Address Space
000b	A16
001b	A24
010b	A32
011b	Reserved
100b	A64
101b	Reserved
110b	Reserved
111b	Reserved

SUPR (Supervisor): If set, the corresponding **VME Slave** is enabled to respond to VMEbus supervisor access cycles.

NPRIV (Non-privileged): If set, the corresponding VME Slave is enabled to respond to non-privileged access cycles.

PGM (Program): If set, the corresponding VME Slave is enabled to respond to VMEbus program access cycles.

DATA (Data): If set, the corresponding VME Slave is enabled to respond to VMEbus data access cycles.

10.4.53 GCSR Base Address Upper Register

This field contains the VMEbus base address of the GCSR registers. The value in this register is compared with VMEbus address bits 63 to 32. This register is only used for during A64 cycles.

Table 105: GCSR Base Address Upper Register

Register Name: GBAU Reset Value: 0x00000000					Register Offset: CRG + 0x400			
Bits	7	6	5	4	3	2	1	0
31:0	GBAU							

GCSR Base Address Upper Register

Bits	Name	Function	PCFS Space Type	Reset By	Reset Value
31:0	GBAU	GCSR Base Address Upper	R/W	P/S	0x00

10.4.54 GCSR Base Address Lower Register

This field contains the VMEbus base address of the GCSR registers. If the VMEbus address is A64 or A32, the value in this register is compared with VMEbus address bits 31 to 5. If the VMEbus address is A24, the value in this register is compared with VMEbus address bits 23 to 5. If the VMEbus address is A16, the value in this register is compared with VMEbus address bits 15 to 5.

Table 106: GCSR Base Address Lower (0-7) Register

Register Name: GBAL Reset Value: 0x00000000				Register Offset: CRG + 0x404				
Bits	7	6	5	4	3	2	1	0
31:24	OFFL							
23:16	OFFL							
15:8	OFFL							
7:0	OFFL			Reserved				

GCSR Base Address Lower (0-7) Register

Bits	Name	Function	PCFS Space Type	Reset By	Reset Value
31:5	OFFL	Offset Lower	R/W	P/S	0x00
4:0	Reserved	N/A	R	N/A	0x00

10.4.55 GCSR Attribute Register

Table 107: GCSR Attribute Register

Register Name: GCSRAT Reset Value: 0x00000000					Register Offset: CRG + 0x408			
Bits	7	6	5	4	3	2	1	0
31:24	Reserved							
23:16	Reserved							
15:8	Reserved							
7:0	EN	AS2	AS1	AS0	SUPR	NPRIV	PGM	DATA

GCSR Base Address Lower (0-7) Register

Bits	Name	Function	PCFS Space Type	Reset By	Reset Value
31:8	Reserved	N/A	R	N/A	0x00
7	EN	Enable	R/W	P/S	0x00
6	AS2	Address Space	R/W	P/S	0x00
5	AS1	Address Space	R/W	P/S	0x00
4	AS0	Address Space	R/W	P/S	0x00
3	SUPR	Supervisor	R/W	P/S	0x00
2	NPRIV	Non-privileged	R/W	P/S	0x00
1	PGM	Program	R/W	P/S	0x00
0	DATA	Data	R/W	P/S	0x00

EN (Enable): If set, access to the GCSR registers is enabled.

AS (Address Space): These bits define the address space the GCSR decoder responds to.

Table 108: VMEbus Address Space

AS	Address Space
000b	A16
001b	A24
010b	A32
011b	Reserved
100b	A64
101b	Reserved
110b	Reserved
111b	Reserved

NPRIV (Non-privileged): If set, the GCSR decoder is enabled to respond to non-privileged access cycles.

SUPR (Supervisor): If set, the GCSR decoder is enabled to respond to VMEbus supervisor access cycles.

PGM (Program): If set, the GCSR decoder is enabled to respond to VMEbus program access cycles.

DATA (Data): If set, the GCSR decoder is enabled to respond to VMEbus data access cycles.

10.4.56 CRG Base Address Upper Register

This field contains the VMEbus base address of the CRG registers. The value in this register is compared with VMEbus address bits 63 to 32. This register is only used for during A64 cycles.

Table 109: CRG Base Address Upper Register

Register Name: CBAU Reset Value: 0x00000000					Register Offset: CRG + 0x40C			
Bits	7	6	5	4	3	2	1	0
31:0	CBAU							

CRG Base Address Upper Register

Bits	Name	Function	PCFS Space Type	Reset By	Reset Value
31:0	CBAU	CRG Base Address Upper	R/W	P/S/L	0x00

10.4.57 CRG Base Address Lower Register

This field contains the VMEbus base address of the CRG registers. If the VMEbus address is A64 or A32, the value in this register is compared with VMEbus address bits 31 to 12. If the VMEbus address is A24, the value in this register is compared with VMEbus address bits 23 to 12. If the VMEbus address is A16, the value in this register is compared with VMEbus address bits 15 to 12.

Table 110: CRG Base Address Lower Register

Register Name: CBAL Reset Value: 0x00000000				Register Offset: CRG + 0x410				
Bits	7	6	5	4	3	2	1	0
31:24	CBAL							
23:16	CBAL							
15:8	CBAL				Reserved			
7:0	Reserved							

CBAL Base Address Lower Register

Bits	Name	Function	PCFS Space Type	Reset By	Reset Value
31:12	CBAU	CRG Base Address Lower	R/W	P/S/L	0x00
11:0	Reserved	N/A	R/W	N/A	0x00

10.4.58 CRG Attribute Register

Table 111: CRG Attribute Register

Register Name: CRGAT Reset Value: 0x00000000					Register Offset: CRG + 0x414			
Bits	7	6	5	4	3	2	1	0
31:24	Reserved							
23:16	Reserved							
15:8	Reserved							
7:0	EN	AS2	AS1	AS0	SUPR	NPRIV	PGM	DATA

CRG Base Address Lower (0-7) Register

Bits	Name	Function	PCFS Space Type	Reset By	Reset Value
31:8	Reserved	N/A	R	N/A	0x00
7	EN	Enable	R/W	P/S/L	0x00
6	AS2	Address Space	R/W	P/S/L	0x00
5	AS1	Address Space	R/W	P/S/L	0x00
4	AS0	Address Space	R/W	P/S/L	0x00
3	SUPR	Supervisor	R/W	P/S/L	0x00
2	NPRIV	Non-privileged	R/W	P/S/L	0x00
1	PGM	Program	R/W	P/S/L	0x00
0	DATA	Data	R/W	P/S/L	0x00

EN (Enable): If set, access to the CRG is enabled.

AS (Address Space): These bits define the address space the CRG decoder responds to.

Table 112: VMEbus Address Space

AS	Address Space
000b	A16
001b	A24
010b	A32
011b	Reserved
100b	A64
101b	Reserved
110b	Reserved
111b	Reserved

NPRIV (Non-privileged): If set, the CRG decoder is enabled to respond to non-privileged access cycles.

SUPR (Supervisor): If set, the CRG decoder is enabled to respond to VMEbus supervisor access cycles.

PGM (Program): If set, the CRG decoder is enabled to respond to VMEbus program access cycles.

DATA (Data): If set, the CRG decoder is enabled to respond to VMEbus data access cycles.

10.4.59 CR/CSR Offset Upper Register

This field contains the offset that is added to the internal VMEbus address bits 63 to 32 to create the PCI/X bus address. During CR/CSR cycles, the internal VMEbus address bits 63 to 32 are forced to zero.

Table 113: CR/CSR Offset Upper Register

Register Name: CROU Reset Value: 0x00000000					Register Offset: CRG + 0x418			
Bits	7	6	5	4	3	2	1	0
31:0	CROU							

CR/CSR Offset Upper Register

Bits	Name	Function	PCFS Space Type	Reset By	Reset Value
31:0	CROU	CR/CSR Offset Upper	R/W	P/S	0x00

10.4.60 CR/CSR Offset Lower Register

This field contains the offset that is added to the internal VMEbus address bits 31 to 19 to create the PCI/X bus address. During CR/CSR cycles, the internal VMEbus address bits 31 to 19 are forced to zero.

Table 114: CR/CSR Offset Lower Register

Register Name: CROL Reset Value: 0x00000000				Register Offset: CRG + 0x41C				
Bits	7	6	5	4	3	2	1	0
31:24	CROL							
23:16	CROL					Reserved		
15:8	Reserved							
7:0	Reserved							

CR/CSR Offset Lower Register

Bits	Name	Function	PCFS Space Type	Reset By	Reset Value
31:19	CROL	CR/CSR Base Address Lower	R/W	P/S	0x00
18:0	Reserved	N/A	R	N/A	0x00

10.4.61 CR/CSR Attribute Register

Table 115: CRG Attribute Register

Register Name: CRAT Reset Value: 0x00000000					Register Offset: CRG + 0x420			
Bits	7	6	5	4	3	2	1	0
31:24	Reserved							
23:16	Reserved							
15:8	Reserved							
7:0	EN	Reserved						

CRG Attribute Register

Bits	Name	Function	PCFS Space Type	Reset By	Reset Value
31:8	Reserved	N/A	R	N/A	0x00
7	EN	Enable	R/W	P/S	0xxx
6:0	Reserved	N/A	R	N/A	0x00

EN (Enable): If set, access to the CR/CSR registers are enabled. The initial value of this bit is determined the hardware configuration (see [Section 5.4.2.1 on page 131](#)).

10.4.62 Location Monitor Base Address Upper Register

This field contains the VMEbus base address of the Locations to be monitored. The value in this register is compared with VMEbus address bits 63 to 32. This register is only used for during A64 cycles.

Table 116: Location Monitor Base Address Upper Register

Register Name: LMBAU Reset Value: 0x00000000				Register Offset: CRG + 0x424				
Bits	7	6	5	4	3	2	1	0
31:0	LMBAU							

Location Monitor Base Address Upper Register

Bits	Name	Function	PCFS Space Type	Reset By	Reset Value
31:0	LMBAU	Location Monitor Base Address Upper	R/W	P/S/L	0x00

10.4.63 Location Monitor Base Address Lower Register

This field contains the VMEbus base address of the location to be monitored. If the VMEbus address is A64 or A32, the value in this register is compared with VMEbus address bits 31 to 5. If the VMEbus address is A24, the value in this register is compared with VMEbus address bits 23 to 5. If the VMEbus address is A16, the value in this register is compared with VMEbus address bits 15 to 5.

Table 117: Location Monitor Base Address Lower Register

Register Name: LMBAL Reset Value: 0x00000000				Register Offset: CRG + 0x428				
Bits	7	6	5	4	3	2	1	0
31:24	LMBAL							
23:16	LMBAL							
15:8	LMBAL							
7:0	LMBAL			Reserved				

CR/CSR Offset Lower Register

Bits	Name	Function	PCFS Space Type	Reset By	Reset Value
31:5	LMBAL	Location Monitor Base Address Lower	R/W	P/S/L	0x00
4:0	Reserved	N/A	R	N/A	0x00

10.4.64 Location Monitor Attribute Register

Table 118: Location Monitor Register

Register Name: LMAT Reset Value: 0x00000000				Register Offset: CRG + 0x42C				
Bits	7	6	5	4	3	2	1	0
31:24	Reserved							
23:16	Reserved							
15:8	Reserved							
7:0	EN	AS2	AS1	AS0	SUPR	NPRIV	PGM	DATA

Location Monitor Register

Bits	Name	Function	PCFS Space Type	Reset By	Reset Value
31:8	Reserved	N/A	R	N/A	0x00
7	EN	Enable	R/W	P/S/L	0x00
6	AS2	Address Space	R/W	P/S/L	0x00
5	AS1	Address Space	R/W	P/S/L	0x00
4	AS0	Address Space	R/W	P/S/L	0x00
3	SUPR	Supervisor	R/W	P/S/L	0x00
2	NPRIV	Non-privileged	R/W	P/S/L	0x00
1	PGM	Program	R/W	P/S/L	0x00
0	DATA	Data	R/W	P/S/L	0x00

EN (Enable): If set, the location monitor is enabled.

AS (Address Space): These bits define the address space the location monitor responds to:

Table 119: VMEbus Address Space

AS	Address Space
000b	A16
001b	A24
010b	A32
011b	Reserved
100b	A64
101b	Reserved
110b	Reserved
111b	Reserved

NPRIV (Non-privileged): If set, the location monitor is enabled to respond to non-privileged access cycles.

SUPR (Supervisor): If set, the location monitor is enabled to respond to VMEbus supervisor access cycles.

PGM (Program): If set, the location monitor is enabled to respond to VMEbus program access cycles.

DATA (Data): If set, the location monitor is enabled to respond to VMEbus data access cycles.

10.4.65 64-bit Counter Upper

These bits are the most significant bits of the 64-bit counter. The 64-bit counter can be used to count events on the VMEbus IRQ[1]I_ or IRQ[2]I_ signal lines. Since the 64-bit counter is comprised of two 32-bit registers, it is possible that the lower counter may roll over between a read or write of the upper and lower portions. Software must consider this case.

Table 120: 64-bit Counter Upper Register

Register Name: 64BCU Reset Value: 0x00000000				Register Offset: CRG + 0x430				
Bits	7	6	5	4	3	2	1	0
31:0	64BCU							

64-bit Counter Upper Register

Bits	Name	Function	PCFS Space Type	Reset By	Reset Value
31:0	64BCU	64-bit Counter Upper	R/W	P/S	0x00

10.4.66 64-bit Counter Lower

These bits are the least significant bits of the 64-bit counter. The 64-bit counter can be used to count events on the VMEbus IRQ[1]I_ or IRQ[2]I_ signal lines. Since the 64-bit counter is comprised of two 32-bit registers, it is possible that the lower counter may roll over between a read or write of the upper and lower portions. Software must consider this case.

Table 121: 64-bit Counter Lower Register

Register Name: 64BCL Reset Value: 0x00000000				Register Offset: CRG + 0x434				
Bits	7	6	5	4	3	2	1	0
31:0	64BCL							

64-bit Counter Lower Register

Bits	Name	Function	PCFS Space Type	Reset By	Reset Value
31:0	64BCL	64-bit Counter Lower	R/W	P/S	0x00

10.4.67 Broadcast Pulse Generator Timer Register

The value in this register is compared to that of the internal Broadcast Pulse Generator Counter. When they are equal, a broadcast interrupt pulse is generated and the counter is reset to 0. The value in this register determines the broadcast interrupt pulse width in approximately 30-ns increments. Due to the required glitch filters on the VMEbus IRQ[1]I_ and IRQ[2]I_ signal lines, the value written to this register must be greater than 0x0003. Approximately, the broadcast interrupt pulse width is programmable from 120 ns to 1.97 ms. After power-up, this register is initialized to 0x0022 which produces a 1.02- μ s pulse if broadcast pulse mode is enabled. Writing a value of all zeros to this register has no effect.

Table 122: Broadcast Pulse Generator Timer Register

Register Name: BPGTR Reset Value: 0x000022				Register Offset: CRG + 0x438				
Bits	7	6	5	4	3	2	1	0
31:24	Reserved							
23:16	Reserved							
15:8	BPGT							
7:0	BPGT							

Broadcast Pulse Generator Timer Register

Bits	Name	Function	PCFS Space Type	Reset By	Reset Value
31:16	Reserved	N/A	R	N/A	0x00
15:0	BPGT	Broadcast Pulse Generator Timer	R/W	P/S	0x22

10.4.68 Broadcast Programmable Clock Timer Register

The value in this register is compared to that of the internal Broadcast Programmable Clock Counter. When they are equal, a broadcast interrupt clock is generated and the counter is reset to 0. The value in this register determines the broadcast interrupt clock rate in approximately 1.02- μ s increments. Due to the required glitch filters on the VMEbus IRQ[1]I_ and IRQ[2]I_ signal lines, the value written to this register must be greater than 0x000001. Approximately, the broadcast interrupt clock rate is programmable from 2.04 μ s to 17.11 seconds. After power-up, this register is initialized to 0x0003E8 which produces a 1.02-ms clock if broadcast programmable clock mode is enabled. Writing a value of all zeros to this register has no effect.

Table 123: Broadcast Programmable Clock Timer Register

Register Name: BPCTR Reset Value: 0x000003E8					Register Offset: CRG + 0x43C			
Bits	7	6	5	4	3	2	1	0
31:24	Reserved							
23:16	BPCT							
15:8	BPCT							
7:0	BPCT							

Broadcast Programmable Clock Timer Register

Bits	Name	Function	PCFS Space Type	Reset By	Reset Value
31:24	Reserved	N/A	R	N/A	0x00
23:0	BPCT	Broadcast Programmable Clock Timer	R/W	P/S	0x3E8

10.4.69 VMEbus Interrupt Control Register

The VMEbus Interrupt Control Register is used to control the VMEbus interrupt function.

Table 124: VMEbus Interrupt Control Register

Register Name: VICR Reset Value: 0x0000000F				Register Offset: CRG + 0x440				
Bits	7	6	5	4	3	2	1	0
31:24	CNTS		EDGIS		IRQIF		IRQ2F	
23:16	BIP	BIPS	Reserved					
15:8	IRQC	IRQLS			IRQS	IRQL		
7:0	STID							

VMEbus Interrupt Control Register

Bits	Name	Function	PCFS Space Type	Reset By	Reset Value
31:30	CNTS	Counter Source	R/W	P/S	0x00
29:28	EDGIS	Edge Interrupt Source	R/W	P/S	0x00
27:26	IRQIF	IRQ1 Function	R/W	P/S	0x00
25:24	IRQ2F	IRQ2 Function	R/W	P/S	0x00
23	BIP	Broadcast Interrupt Pulse	S	-	0x00
22	BIPS	Broadcast Interrupt Pulse Status	R	P/S	0x00
21:16	Reserved	N/A	R	N/A	0x00
15	IRQC	VMEbus IRQ Clear	S	-	0x00
14:12	IRQLS	VMEbus IRQ Level Status	R	P/S	0x00
11	IRQS	VMEbus IRQ Status	R	P/S	0x00
10:8	IRQL	VMEbus IRQ Level	S	-	0x00
7:0	STID	STATUS/ID	R/W	P/S	0x0F

CNTS (Counter Source): These bits define input to the 64-bit counter.

Table 125: Counter Source

CNTS	Counter Source
00b	Counter Disable
01b	IRQ[1]I_ to Counter
10b	IRQ[2]I_ to Counter
11b	Reserved

EDGIS (Edge Interrupt Source): These bits define input to VMEbus edge interrupt logic.

Table 126: Edge Interrupt Source

EDGIS	Edge Interrupt Source
00b	Edge Interrupt Disable
01b	IRQ[1]I_ to Edge Interrupt
10b	IRQ[2]I_ to Edge Interrupt
11b	Reserved

IRQ1F (IRQ1 Function): These bits define the function of the VMEbus IRQ[1]O signal line as an output.

Table 127: VMEbus IRQ[1]O Function

IRQ1F	VMEbus IRQ[1]O Function
00b	Normal
01b	Pulse Generator
10b	Programmable Clock
11b	1.02 μ s Clock

IRQ2F (IRQ2 Function): These bits define the function of the VMEbus IRQ[2]O signal line as an output.

Table 128: VMEbus IRQ[2]O Function

IRQ2F	VMEbus IRQ[2]O Function
00b	Normal
01b	Pulse Generator
10b	Programmable Clock
11b	1.02 μ s Clock

BIP (Broadcast Interrupt Pulse): When the broadcast interrupt pulse mode is enabled, setting this bit causes a pulse to be generated on the VMEbus IRQ[1]O or IRQ[2]O signal line. This bit always reads zero and writing a zero has no effect.

BIPS (Broadcast Interrupt Pulse Status): When this bit is high, the broadcast interrupt pulse is still being generated by the pulse generator. When this bit is low, the pulse generator has finished generating the broadcast interrupt pulse. This is a read only status bit.

IRQC (VMEbus IRQ Clear): When this bit is set high, the IRQL bits are reset and the VMEbus interrupt is removed. This bit should only be used to recover from an error condition. Normally VMEbus interrupts should not be removed. This bit always reads zero and writing a zero has no effect.

IRQLS (VMEbus IRQ Level Status): These bits are read-only status bits and they define the current level of a pending VMEbus interrupt.

IRQS (VMEbus IRQ Status): When this bit is high, the VMEbus interrupt has not been acknowledged. When this bit is low, the VMEbus interrupt has been acknowledged. This is a read only status bit.

IRQL (VMEbus IRQ Level): These bits define the level of the VMEbus interrupt generated by the Tsi148. A VMEbus interrupt is generated by writing the desired level to these bits. These bits always read 0 and writing a 0 to these bits has no effect. These bits are automatically cleared following the VMEbus interrupt acknowledge cycle.

STID (STATUS/ID): These bits define the VMEbus vector that is returned during an interrupt acknowledge cycle.

10.4.70 Interrupt Enable Register

Table 129: Interrupt Enable Register

Register Name: INTEN Reset Value: 0x00000000					Register Offset: CRG + 448			
Bits	7	6	5	4	3	2	1	0
31:24	Reserved						DMA1EN	DMA0EN
23:16	LM3EN	LM2EN	LM1EN	LM0EN	MB3EN	MB2EN	MB1EN	MB0EN
15:8	Reserved		PERREN	VERREN	VIEEN	IACKEN	SYSFLEN	ACFLEN
7:0	IRQ7EN	IRQ6EN	IRQ5EN	IRQ4EN	IRQ3EN	IRQ2EN	IRQ1EN	Reserved

Interrupt Enable Register

Bits	Name	Function	PCFS Space Type	Reset By	Reset Value
31:26	Reserved	N/A	R	N/A	0x00
25	DMA1EN	DMAC 1 Interrupt Enable	R/W	P/S/L	0x00
24	DMA0EN	DMAC 0 Interrupt Enable	R/W	P/S/L	0x00
23	LM3EN	Location Monitor 3 Interrupt Enable	R/W	P/S/L	0x00
22	LM2EN	Location Monitor 2 Interrupt Enable	R/W	P/S/L	0x00
21	LM1EN	Location Monitor 1 Interrupt Enable	R/W	P/S/L	0x00
20	LM0EN	Location Monitor 0 Interrupt Enable	R/W	P/S/L	0x00
19	MB3EN	Mail Box 3 Interrupt Enable	R/W	P/S/L	0x00
18	MB2EN	Mail Box 2 Interrupt Enable	R/W	P/S/L	0x00
17	MB1EN	Mail Box 1 Interrupt Enable	R/W	P/S/L	0x00
16	MB0EN	Mail Box 0 Interrupt Enable	R/W	P/S/L	0x00
15:14	Reserved	N/A	R	N/A	0x00
13	PERREN	PCI/X Bus Error Interrupt Enable	R/W	P/S/L	0x00
12	VERREN	VMEbus Error Interrupt Enable	R/W	P/S/L	0x00
11	VIEEN	VMEbus IRQ Edge Interrupt Enable	R/W	P/S/L	0x00
10	IACKEN	Interrupt Acknowledge Interrupt Enable	R/W	P/S/L	0x00

Interrupt Enable Register

Bits	Name	Function	PCFS Space Type	Reset By	Reset Value
9	SYSFLEN	System Fail Interrupt Enable	R/W	P/S/L	0x00
8	ACFLEN	AC Fail Interrupt Enable	R/W	P/S/L	0x00
7	IRQ7EN	IRQ7 Enable	R/W	P/S/L	0x00
6	IRQ6EN	IRQ6 Enable	R/W	P/S/L	0x00
5	IRQ5EN	IRQ5 Enable	R/W	P/S/L	0x00
4	IRQ4EN	IRQ4 Enable	R/W	P/S/L	0x00
3	IRQ3EN	IRQ3 Enable	R/W	P/S/L	0x00
2	IRQ2EN	IRQ2 Enable	R/W	P/S/L	0x00
1	IRQ1EN	IRQ1 Enable	R/W	P/S/L	0x00
0	Reserved	N/A	R	N/A	0x00

DMA1EN (DMAC 1 Interrupt Enable): When this bit is high, the DMA 1 controller interrupt is enabled. When the interrupt is enabled, the status bit indicates the state of the DMA 1 controller interrupt. A local bus interrupt is generated if the corresponding interrupt out bit is set. The interrupt can be polled by setting the enable bit and clearing the interrupt out bit.

DMA0EN (DMAC 0 Interrupt Enable): When this bit is high, the DMA 0 controller interrupt is enabled. When the interrupt is enabled, the status bit indicates the state of the DMA 0 controller interrupt. A local bus interrupt is generated if the corresponding interrupt out bit is set. The interrupt can be polled by setting the enable bit and clearing the interrupt out bit.

LM3EN (Location Monitor 3 Interrupt Enable): When this bit is high, the location monitor 3 interrupt is enabled. When the interrupt is enabled, the status bit indicates the state of the location monitor 3 interrupt. A local bus interrupt is generated if the corresponding interrupt out bit is set. The interrupt can be polled by setting the enable bit and clearing the interrupt out bit.

LM2EN (Location Monitor 2 Interrupt Enable): When this bit is high, the location monitor 2 interrupt is enabled. When the interrupt is enabled, the status bit indicates the state of the location monitor 2 interrupt. A local bus interrupt is generated if the corresponding interrupt out bit is set. The interrupt can be polled by setting the enable bit and clearing the interrupt out bit.

LM1EN (Location Monitor 1 Interrupt Enable): When this bit is high, the location monitor 1 interrupt is enabled. When the interrupt is enabled, the status bit indicates the state of the location monitor 1 interrupt. A local bus interrupt is generated if the corresponding interrupt out bit is set. The interrupt can be polled by setting the enable bit and clearing the interrupt out bit.

LM0EN (Location Monitor 0 Interrupt Enable): When this bit is high, the location monitor 0 interrupt is enabled. When the interrupt is enabled, the status bit indicates the state of the location monitor 0 interrupt. A local bus interrupt is generated if the corresponding interrupt out bit is set. The interrupt can be polled by setting the enable bit and clearing the interrupt out bit.

MB3EN (Mail Box 3 Interrupt Enable): When this bit is high, the mail box 3 interrupt is enabled. When the interrupt is enabled, the status bit indicates the state of the mail box 3 interrupt. A local bus interrupt is generated if the corresponding interrupt out bit is set. The interrupt can be polled by setting the enable bit and clearing the interrupt out bit.

MB2EN (Mail Box 2 Interrupt Enable): When this bit is high, the mail box 2 interrupt is enabled. When the interrupt is enabled, the status bit indicates the state of the mail box 2 interrupt. A local bus interrupt is generated if the corresponding interrupt out bit is set. The interrupt can be polled by setting the enable bit and clearing the interrupt out bit.

MB1EN (Mail Box 1 Interrupt Enable): When this bit is high, the mail box 1 interrupt is enabled. When the interrupt is enabled, the status bit indicates the state of the mail box 1 interrupt. A local bus interrupt is generated if the corresponding interrupt out bit is set. The interrupt can be polled by setting the enable bit and clearing the interrupt out bit.

MB0EN (Mail Box 0 Interrupt Enable): When this bit is high, the mail box 0 interrupt is enabled. When the interrupt is enabled, the status bit indicates the state of the mail box 0 interrupt. A local bus interrupt is generated if the corresponding interrupt out bit is set. The interrupt can be polled by setting the enable bit and clearing the interrupt out bit.

PERREN (PCI/X Bus Error Interrupt Enable): When this bit is high, the PCI/X bus error is enabled. When the interrupt is enabled, the status bit indicates the state of the PCI/X bus error interrupt. A local bus interrupt is generated if the corresponding interrupt out bit is set. The interrupt can be polled by setting the enable bit and clearing the interrupt out bit.

VERREN (VMEbus Error Interrupt Enable): When this bit is high, the VMEbus error interrupt is enabled. When the interrupt is enabled, the status bit indicates the state of the VMEbus error interrupt. A local bus interrupt is generated if the corresponding interrupt out bit is set. The interrupt can be polled by setting the enable bit and clearing the interrupt out bit.

VIEEN (VMEbus IRQ Edge Interrupt Enable): When this bit is high, the VMEbus IRQ edge interrupt is enabled. When the interrupt is enabled, the status bit indicates the state of the VMEbus IRQ edge interrupt. A local bus interrupt is generated if the corresponding interrupt out bit is set. The interrupt can be polled by setting the enable bit and clearing the interrupt out bit.

IACKEN (Interrupt Acknowledge Interrupt Enable): When this bit is high, the VMEbus interrupt acknowledge interrupt is enabled. When the interrupt is enabled, the status bit indicates the state of the VMEbus interrupt acknowledge interrupt. A local bus interrupt is generated if the corresponding interrupt out bit is set. The interrupt can be polled by setting the enable bit and clearing the interrupt out bit.

SYSFLEN (System Fail Interrupt Enable): When this bit is high, the VMEbus system fail interrupt is enabled. When the interrupt is enabled, the status bit indicates the state of the VMEbus system fail interrupt. A local bus interrupt is generated if the corresponding interrupt out bit is set. The interrupt can be polled by setting the enable bit and clearing the interrupt out bit.

ACFLEN (AC Fail Interrupt Enable): When this bit is high, the AC fail interrupt is enabled. When the interrupt is enabled, the status bit indicates the state of the AC fail interrupt. A local bus interrupt is generated if the corresponding interrupt out bit is set. The interrupt can be polled by setting the enable bit and clearing the interrupt out bit.

IRQ7EN (IRQ7 Enable): When this bit is high, the VMEbus IRQ7 interrupt is enabled. When the interrupt is enabled, the status bit indicates the state of the VMEbus IRQ[7]I_ signal line. A local bus interrupt is generated if the corresponding interrupt out bit is set. The interrupt can be polled by setting the enable bit and clearing the interrupt out bit.

IRQ6EN (IRQ6 Enable): When this bit is high, the VMEbus IRQ6 interrupt is enabled. When the interrupt is enabled, the status bit indicates the state of the VMEbus IRQ[6]I_ signal line. A local bus interrupt is generated if the corresponding interrupt out bit is set. The interrupt can be polled by setting the enable bit and clearing the interrupt out bit.

IRQ5EN (IRQ5 Enable): When this bit is high, the VMEbus IRQ5 interrupt is enabled. When the interrupt is enabled, the status bit indicates the state of the VMEbus IRQ[5]I_ signal line. A local bus interrupt is generated if the corresponding interrupt out bit is set. The interrupt can be polled by setting the enable bit and clearing the interrupt out bit.

IRQ4EN (IRQ4 Enable): When this bit is high, the VMEbus IRQ4 interrupt is enabled. When the interrupt is enabled, the status bit indicates the state of the VMEbus IRQ[4]I_ signal line. A local bus interrupt is generated if the corresponding interrupt out bit is set. The interrupt can be polled by setting the enable bit and clearing the interrupt out bit.

IRQ3EN (IRQ3 Enable): When this bit is high, the VMEbus IRQ3 interrupt is enabled. When the interrupt is enabled, the status bit indicates the state of the VMEbus IRQ[3]I_ signal line. A local bus interrupt is generated if the corresponding interrupt out bit is set. The interrupt can be polled by setting the enable bit and clearing the interrupt out bit.

IRQ2EN (IRQ2 Enable): When this bit is high, the VMEbus IRQ2 interrupt is enabled. When the interrupt is enabled, the status bit indicates the state of the VMEbus IRQ[2]I_ signal line. A local bus interrupt is generated if the corresponding interrupt out bit is set. The interrupt can be polled by setting the enable bit and clearing the interrupt out bit.

IRQ1EN (IRQ1 Enable): When this bit is high, the VMEbus IRQ1 interrupt is enabled. When the interrupt is enabled, the status bit indicates the state of the VMEbus IRQ[1]I_ signal line. A local bus interrupt is generated if the corresponding interrupt out bit is set. The interrupt can be polled by setting the enable bit and clearing the interrupt out bit.

10.4.71 Interrupt Enable Out Register

Table 130: Interrupt Enable Out Register

Register Name: INTEO Reset Value: 0x00000000					Register Offset: CRG + 44C			
Bits	7	6	5	4	3	2	1	0
31:24	Reserved						DMA1EO	DMA0EO
23:16	LM3EO	LM2EO	LM1EO	LM0EO	MB3EO	MB2EO	MB1EO	MB0EO
15:8	Reserved		PERREO	VERREO	VIEEO	IACKEO	SYSFLEO	ACFLEO
7:0	IRQ7EO	IRQ6EO	IRQ5EO	IRQ4EO	IRQ3EO	IRQ2EO	IRQ1EO	Reserved

Interrupt Enable Out Register

Bits	Name	Function	PCFS Space Type	Reset By	Reset Value
31:26	Reserved	N/A	R	N/A	0x00
25	DMA1EO	DMAC 1 Interrupt Enable Out	R/W	P/S/L	0x00
24	DMA0EO	DMAC 0 Interrupt Enable Out	R/W	P/S/L	0x00
23	LM3EO	Location Monitor 3 Interrupt Enable Out	R/W	P/S/L	0x00
22	LM2EO	Location Monitor 2 Interrupt Enable Out	R/W	P/S/L	0x00
21	LM1EO	Location Monitor 1 Interrupt Enable Out	R/W	P/S/L	0x00
20	LM0EO	Location Monitor 0 Interrupt Enable Out	R/W	P/S/L	0x00
19	MB3EO	Mail Box 3 Interrupt Enable Out	R/W	P/S/L	0x00
18	MB2EO	Mail Box 2 Interrupt Enable Out	R/W	P/S/L	0x00
17	MB1EO	Mail Box 1 Interrupt Enable Out	R/W	P/S/L	0x00
16	MB0EO	Mail Box 0 Interrupt Enable Out	R/W	P/S/L	0x00
15:14	Reserved	N/A	R	N/A	0x00
13	PERREO	PCI/X Bus Error Interrupt Enable Out	R/W	P/S/L	0x00
12	VERREO	VMEbus Error Interrupt Enable Out	R/W	P/S/L	0x00
11	VIEEO	VMEbus IRQ Edge Interrupt Enable Out	R/W	P/S/L	0x00
10	IACKEO	Interrupt Acknowledge Interrupt Enable Out	R/W	P/S/L	0x00

Interrupt Enable Out Register

Bits	Name	Function	PCFS Space Type	Reset By	Reset Value
9	SYSFLEO	System Fail Interrupt Enable Out	R/W	P/S/L	0x00
8	ACFLEO	AC Fail Interrupt Enable Out	R/W	P/S/L	0x00
7	IRQ7EO	IRQ7 Enable Out	R/W	P/S/L	0x00
6	IRQ6EO	IRQ6 Enable Out	R/W	P/S/L	0x00
5	IRQ5EO	IRQ5 Enable Out	R/W	P/S/L	0x00
4	IRQ4EO	IRQ4 Enable Out	R/W	P/S/L	0x00
3	IRQ3EO	IRQ3 Enable Out	R/W	P/S/L	0x00
2	IRQ2EO	IRQ2 Enable Out	R/W	P/S/L	0x00
1	IRQ1EO	IRQ1 Enable Out	R/W	P/S/L	0x00
0	Reserved	N/A	R	N/A	0x00

DMA1EO (DMA 1 Interrupt Enable Out): When this bit is high, the DMA 1 controller interrupt is enabled to the one of the four INTx pins.

DMA0EO (DMA 0 Interrupt Enable Out): When this bit is high, the DMA 0 controller interrupt is enabled to the one of the four INTx pins.

LM3EO (Location Monitor 3 Interrupt Enable Out): When this bit is high, the location monitor 3 interrupt is enabled to the one of the four INTx pins.

LM2EO (Location Monitor 2 Interrupt Enable Out): When this bit is high, the location monitor 2 interrupt is enabled to the one of the four INTx pins.

LM1EO (Location Monitor 1 Interrupt Enable Out): When this bit is high, the location monitor 1 interrupt is enabled to the one of the four INTx pins.

LM0EO (Location Monitor 0 Interrupt Enable Out): When this bit is high, the location monitor 0 interrupt is enabled to the one of the four INTx pins.

MB3EO (Mail Box 3 Interrupt Enable Out): When this bit is high, the mail box 3 interrupt is enabled to the one of the four INTx pins.

MB2EO (Mail Box 2 Interrupt Enable Out): When this bit is high, the mail box 2 interrupt is enabled to the one of the four INTx pins.

MB1EO (Mail Box 1 Interrupt Enable Out): When this bit is high, the mail box 1 interrupt is enabled to the one of the four INTx pins.

MB0EO (Mail Box 0 Interrupt Enable Out): When this bit is high, the mail box 0 interrupt is enabled to the one of the four INTx pins.

PERREO (PCI/X Bus Error Enable Out): When this bit is high, the PCI/X bus error interrupt is enabled to the one of the four INTx pins.

VERREO (VMEbus Error Interrupt Enable Out): When this bit is high, the VMEbus error interrupt is enabled to the one of the four INTx pins.

VIEEO (VMEbus IRQ Edge Interrupt Enable Out): When this bit is high, the VMEbus IRQ edge interrupt is enabled to the one of the four INTx pins.

IACKEO (Interrupt Acknowledge Interrupt Enable Out): When this bit is high, the VMEbus interrupt acknowledge interrupt is enabled to the one of the four INTx pins.

SYSFLEO (System Fail Interrupt Enable Out): When this bit is high, the VMEbus system fail interrupt is enabled to the one of the four INTx pins.

ACFLEO (AC Fail Interrupt Enable Out): When this bit is high, the AC fail interrupt is enabled to the one of the four INTx pins.

IRQ7EO (IRQ7 Enable Out): When this bit is high, the VMEbus IRQ[7]I_ interrupt is enabled to the one of the four INTx pins.

IRQ6EO (IRQ6 Enable Out): When this bit is high, the VMEbus IRQ[6]I_ interrupt is enabled to the one of the four INTx pins.

IRQ5EO (IRQ5 Enable Out): When this bit is high, the VMEbus IRQ[5]I_ interrupt is enabled to the one of the four INTx pins.

IRQ4EO (IRQ4 Enable Out): When this bit is high, the VMEbus IRQ[4]I_ interrupt is enabled to the one of the four INTx pins.

IRQ3EO (IRQ3 Enable Out): When this bit is high, the VMEbus IRQ[3]I_ interrupt is enabled to the one of the four INTx pins.

IRQ2EO (IRQ2 Enable Out): When this bit is high, the VMEbus IRQ[2]I_ interrupt is enabled to the one of the four INTx pins.

IRQ1EO (IRQ1 Enable Out): When this bit is high, the VMEbus IRQ[1]I_ interrupt is enabled to the one of the four INTx pins.

10.4.72 Interrupt Status Register

Table 131: Interrupt Status Register

Register Name: INTS Reset Value: 0x00000000					Register Offset: CRG + 450			
Bits	7	6	5	4	3	2	1	0
31:24	Reserved						DMA1S	DMA0S
23:16	LM3S	LM2S	LM1S	LM0S	MB3S	MB2S	MB1S	MB0S
15:8	Reserved		PERRS	VERRS	VIES	IACKS	SYSFLS	ACFLS
7:0	IRQ7S	IRQ6S	IRQ5S	IRQ4S	IRQ3S	IRQ2S	IRQ1S	Reserved

Interrupt Enable Status Register

Bits	Name	Function	PCFS Space Type	Reset By	Reset Value
31:26	Reserved	N/A	R	N/A	0x00
25	DMA1S	DMAC 1 Interrupt Enable Status	R	P/S/L	0x00
24	DMA0S	DMAC 0 Interrupt Enable Status	R	P/S/L	0x00
23	LM3S	Location Monitor 3 Interrupt Enable Status	R	P/S/L	0x00
22	LM2S	Location Monitor 2 Interrupt Enable Status	R	P/S/L	0x00
21	LM1S	Location Monitor 1 Interrupt Enable Status	R	P/S/L	0x00
20	LM0S	Location Monitor 0 Interrupt Enable Status	R	P/S/L	0x00
19	MB3S	Mail Box 3 Interrupt Enable Status	R	P/S/L	0x00
18	MB2S	Mail Box 2 Interrupt Enable Status	R	P/S/L	0x00
17	MB1S	Mail Box 1 Interrupt Enable Status	R	P/S/L	0x00
16	MB0S	Mail Box 0 Interrupt Enable Status	R	P/S/L	0x00
15:14	Reserved	N/A	R	N/A	0x00
13	PERRS	PCI/X Bus Error Interrupt Enable Status	R	P/S/L	0x00
12	VERRS	VMEbus Error Interrupt Enable Status	R	P/S/L	0x00
11	VIES	VMEbus IRQ Edge Interrupt Enable Status	R	P/S/L	0x00
10	IACKS	Interrupt Acknowledge Interrupt Enable Status	R	P/S/L	0x00

Interrupt Enable Status Register

Bits	Name	Function	PCFS Space Type	Reset By	Reset Value
9	SYSFLS	System Fail Interrupt Enable Status	R	P/S/L	0x00
8	ACFLS	AC Fail Interrupt Enable Status	R	P/S/L	0x00
7	IRQ7S	IRQ7 Enable Status	R	P/S/L	0x00
6	IRQ6S	IRQ6 Enable Status	R	P/S/L	0x00
5	IRQ5S	IRQ5 Enable Status	R	P/S/L	0x00
4	IRQ4S	IRQ4 Enable Status	R	P/S/L	0x00
3	IRQ3S	IRQ3 Enable Status	R	P/S/L	0x00
2	IRQ2S	IRQ2 Enable Status	R	P/S/L	0x00
1	IRQ1S	IRQ1 Enable Status	R	P/S/L	0x00
0	Reserved	N/A	R	N/A	0x00

DMA1S (DMA 1 Interrupt Status): When this bit is high, a DMA 1 controller interrupt is pending.

DMA0S (DMA 0 Interrupt Status): When this bit is high, a DMA 0 controller interrupt is pending.

LM3S (Location Monitor 3 Interrupt Status): When this bit is high, a location monitor 3 interrupt is pending.

LM2S (Location Monitor 2 Interrupt Status): When this bit is high, a location monitor 2 interrupt is pending.

LM1S (Location Monitor 1 Interrupt Status): When this bit is high, a location monitor 1 interrupt is pending.

LM0S (Location Monitor 0 Interrupt Status): When this bit is high, a location monitor 0 interrupt is pending.

MB3S (Mail Box 3 Interrupt Status): When this bit is high, a mail box 3 interrupt is pending.

MB2S (Mail Box 2 Interrupt Status): When this bit is high, a mail box 2 interrupt is pending.

MB1S (Mail Box 1 Interrupt Status): When this bit is high, a mail box 1 interrupt is pending.

MB0S (Mail Box 0 Interrupt Status): When this bit is high, a mail box 0 interrupt is pending.

PERRS (PCI/X Bus Error Interrupt Status): When this bit is high, a PCI/X bus error interrupt is pending.

VERRS (VMEbus Error Interrupt Status): When this bit is high, a VMEbus error interrupt is pending.

VIES (VMEbus IRQ Edge Interrupt Status): When this bit is high, a VMEbus IRQ edge interrupt is pending.

IACKS (Interrupt Acknowledge Interrupt Status): When this bit is high, an interrupt acknowledge interrupt is pending.

SYSFLS (System Fail Interrupt Status): When this bit is high, a VMEbus system fail interrupt is pending.

ACFLS (AC Fail Interrupt Status): When this bit is high, a VMEbus AC fail interrupt is pending.

IRQ7S (IRQ7 Status): When this bit is high, a VMEbus IRQ[7]I_ interrupt is pending.

IRQ6S (IRQ6 Status): When this bit is high, a VMEbus IRQ[6]I_ interrupt is pending.

IRQ5S (IRQ5 Status): When this bit is high, a VMEbus IRQ[5]I_ interrupt is pending.

IRQ4S (IRQ4 Status): When this bit is high, a VMEbus IRQ[4]I_ interrupt is pending.

IRQ3S (IRQ3 Status): When this bit is high, a VMEbus IRQ[3]I_ interrupt is pending.

IRQ2S (IRQ2 Status): When this bit is high, a VMEbus IRQ[2]I_ interrupt is pending.

IRQ1S (IRQ1 Status): When this bit is high, a VMEbus IRQ[1]I_ interrupt is pending.

10.4.73 Interrupt Clear Register

Table 132: Interrupt Clear Register

Register Name: INTC Reset Value: 0x00000000					Register Offset: CRG + 454			
Bits	7	6	5	4	3	2	1	0
31:24	Reserved						DMA1C	DMA0C
23:16	LM3C	LM2C	LM1C	LM0C	MB3C	MB2C	MB1C	MBOC
15:8	Reserved		PERRC	VERRC	VIEC	IACKC	SYSFLC	ACFLC
7:0	Reserved							

Interrupt Enable Clear Register

Bits	Name	Function	PCFS Space Type	Reset By	Reset Value
31:26	Reserved	N/A	R	N/A	0x00
25	DMA1C	DMAC 1 Interrupt Clear	C	-	0x00
24	DMA0C	DMAC 0 Interrupt Clear	C	-	0x00
23	LM3C	Location Monitor 3 Interrupt Clear	C	-	0x00
22	LM2C	Location Monitor 2 Interrupt Clear	C	-	0x00
21	LM1C	Location Monitor 1 Interrupt Clear	C	-	0x00
20	LM0C	Location Monitor 0 Interrupt Clear	C	-	0x00
19	MB3C	Mail Box 3 Interrupt Clear	C	-	0x00
18	MB2C	Mail Box 2 Interrupt Clear	C	-	0x00
17	MB1C	Mail Box 1 Interrupt Clear	C	-	0x00
16	MBOC	Mail Box 0 Interrupt Clear	C	-	0x00
15:14	Reserved	N/A	R	N/A	0x00
13	PERRC	PCI/X Bus Error Interrupt Clear	C	-	0x00
12	VERRC	VMEbus Error Interrupt Clear	C	-	0x00
11	VIEC	VMEbus IRQ Edge Interrupt Clear	C	-	0x00
10	IACKC	Interrupt Acknowledge Interrupt Clear	C	-	0x00

Interrupt Enable Clear Register

Bits	Name	Function	PCFS Space Type	Reset By	Reset Value
9	SYSFLC	System Fail Interrupt Clear	C	-	0x00
8	ACFLC	AC Fail Interrupt Clear	C	-	0x00
7:0	Reserved	N/A	R	N/A	0x00

DMA1C (DMA 1 Interrupt Clear): When this bit is set, the DMA 1 controller interrupt is cleared. This bit always reads zero and writing a zero has no effect.

DMA0C (DMA 0 Interrupt Clear): When this bit is set, the DMA 0 controller interrupt is cleared. This bit always reads zero and writing a zero has no effect.

LM3C (Location Monitor 3 Interrupt Clear): When this bit is set, the location monitor 3 interrupt is cleared. This bit always reads zero and writing a zero has no effect.

LM2C (Location Monitor 2 Interrupt Clear): When this bit is set, the location monitor 2 interrupt is cleared. This bit always reads zero and writing a zero has no effect.

LM1C (Location Monitor 1 Interrupt Clear): When this bit is set, the location monitor 1 interrupt is cleared. This bit always reads zero and writing a zero has no effect.

LM0C (Location Monitor 0 Interrupt Clear): When this bit is set, the location monitor 0 interrupt is cleared. This bit always reads zero and writing a zero has no effect.

MB3C (Mail Box 3 Interrupt Clear): When this bit is set, the mail box 3 interrupt is cleared. This bit always reads zero and writing a zero has no effect.

MB2C (Mail Box 2 Interrupt Clear): When this bit is set, the mail box 2 interrupt is cleared. This bit always reads zero and writing a zero has no effect.

MB1C (Mail Box 1 Interrupt Clear): When this bit is set, the mail box 1 interrupt is cleared. This bit always reads zero and writing a zero has no effect.

MB0C (Mail Box 0 Interrupt Clear): When this bit is set, the mail box 0 interrupt is cleared. This bit always reads zero and writing a zero has no effect.

PERRC (PCI/X Bus Error Interrupt Clear): When this bit is set, the PCI/X bus error interrupt is cleared. This bit always reads zero and writing a zero has no effect.

VERRC (VMEbus Error Interrupt Clear): When this bit is set, the VMEbus error interrupt is cleared. This bit always reads zero and writing a zero has no effect.

VIEC (VMEbus IRQ Edge Interrupt Clear): When this bit is set, the VMEbus IRQ edge interrupt is cleared. This bit always reads zero and writing a zero has no effect.

IACKC (Interrupt Acknowledge Interrupt Clear): When this bit is set, the VMEbus interrupt acknowledge interrupt is cleared. This bit always reads zero and writing a zero has no effect.

SYSFLC (System Fail Interrupt Clear): When this bit is set, the VMEbus system fail interrupt is cleared. This bit always reads zero and writing a zero has no effect.

ACFLC (AC Fail Interrupt Clear): When this bit is set, the AC fail interrupt is cleared. This bit always reads zero and writing a zero has no effect.

10.4.74 Interrupt Map 1 Register

Table 133: Interrupt Map 1 Register

Register Name: INTM1 Reset Value: 0x00000000				Register Offset: CRG + 458				
Bits	7	6	5	4	3	2	1	0
31:24	Reserved							
23:16	Reserved			DMA1M		DMA0M		
15:8	LM3M		LM2M		LM1M		LM0M	
7:0	MB3M		MB2M		MB1M		MB0M	

Interrupt Map 1 Register

Bits	Name	Function	PCFS Space Type	Reset By	Reset Value
31:20	Reserved	N/A	R	N/A	0x00
19:18	DMA1M	DMA 1 Interrupt Map	R/W	P/S/L	0x00
17:16	DMA0M	DMA 0 Interrupt Map	R/W	P/S/L	0x00
15:14	LM3M	Location Monitor 3 Map	R/W	P/S/L	0x00
13:12	LM2M	Location Monitor 2 Map	R/W	P/S/L	0x00
11:10	LM1M	Location Monitor 1 Map	R/W	P/S/L	0x00
9:8	LM0M	Location Monitor 0 Map	R/W	P/S/L	0x00
7:6	MB3M	Mail Box 3 Map	R/W	P/S/L	0x00
5:4	MB2M	Mail Box 2 Map	R/W	P/S/L	0x00
3:2	MB1M	Mail Box 1 Map	R/W	P/S/L	0x00
1:0	MB0M	Mail Box 0 Map	R/W	P/S/L	0x00

DMA1M (DMA 1 Interrupt Map): These bits indicate which INTx signal line the interrupt is routed to. The values 0 - 3 maps the interrupts to INTA_ - INTD_ respectively.

DMA0M (DMA 0 Interrupt Map): These bits indicate which INTx signal line the interrupt is routed to. The values 0 - 3 maps the interrupts to INTA_ - INTD_ respectively.

LM3M (Location Monitor 3 Map): These bits indicate which INTx signal line the interrupt is routed to. The values 0 - 3 maps the interrupts to INTA_ - INTD_ respectively.

LM2M (Location Monitor 2 Map): These bits indicate which INTx signal line the interrupt is routed to. The values 0 - 3 maps the interrupts to INTA_ - INTD_ respectively.

LM1M (Location Monitor 1 Map): These bits indicate which INTx signal line the interrupt is routed to. The values 0 - 3 maps the interrupts to INTA_ - INTD_ respectively.

LM0M (Location Monitor 0 Map): These bits indicate which INTx signal line the interrupt is routed to. The values 0 - 3 maps the interrupts to INTA_ - INTD_ respectively.

MB3M (Mail Box 3 Map): These bits indicate which INTx signal line the interrupt is routed to. The values 0 - 3 maps the interrupts to INTA_ - INTD_ respectively.

MB2M (Mail Box 2 Map): These bits indicate which INTx signal line the interrupt is routed to. The values 0 - 3 maps the interrupts to INTA_ - INTD_ respectively.

MB1M (Mail Box 1 Map): These bits indicate which INTx signal line the interrupt is routed to. The values 0 - 3 maps the interrupts to INTA_ - INTD_ respectively.

MB0M (Mail Box 0 Map): These bits indicate which INTx signal line the interrupt is routed to. The values 0 - 3 maps the interrupts to INTA_ - INTD_ respectively.

10.4.75 Interrupt Map 2 Register

Table 134: Interrupt Map 2 Register

Register Name: INTM2 Reset Value: 0x00000000					Register Offset: CRG + 45C			
Bits	7	6	5	4	3	2	1	0
31:24	Reserved				PERRM		VERRM	
23:16	VIEM		IACKM		SYSFLM		ACFLM	
15:8	IRQ7M		IRQ6M		IRQ5M		IRQ4M	
7:0	IRQ3M		IRQ2M		IRQ1M		Reserved	

Interrupt Map 2 Register

Bits	Name	Function	PCFS Space Type	Reset By	Reset Value
31:20	Reserved	N/A	R	N/A	0x00
27:26	PERRM	PCI/X Bus Error Interrupt Map	R/W	P/S/L	0x00
25:24	VERRM	VMEbus Error Interrupt Map	R/W	P/S/L	0x00
23:22	VIEM	VMEbus IRQ Edge Interrupt Map	R/W	P/S/L	0x00
21:20	IACKM	Interrupt Acknowledge Interrupt Map	R/W	P/S/L	0x00
19:18	SYSFLM	System Fail Interrupt Map	R/W	P/S/L	0x00
17:16	ACFLM	AC Fail Interrupt Map	R/W	P/S/L	0x00
15:14	IRQ7M	IRQ7 Map	R/W	P/S/L	0x00
13:12	IRQ6M	IRQ6 Map	R/W	P/S/L	0x00
11:10	IRQ5M	IRQ5Map	R/W	P/S/L	0x00
9:8	IRQ4M	IRQ4 Map	R/W	P/S/L	0x00
7:6	IRQ3M	IRQ3 Map	R/W	P/S/L	0x00
5:4	IRQ2M	IRQ27 Map	R/W	P/S/L	0x00
3:2	IRQ1M	IRQ1 Map	R/W	P/S/L	0x00
1:0	Reserved	N/A	R	N/A	0x00

PERRM (PCI/X Bus Error Interrupt Map): These bits indicate which INTx signal line the interrupt is routed to. The values 0 - 3 maps the interrupts to INTA_ - INTD_ respectively.

VERRM (VMEbus Error Interrupt Map): These bits indicate which INTx signal line the interrupt is routed to. The values 0 - 3 maps the interrupts to INTA_ - INTD_ respectively.

VIEM (VMEbus IRQ Edge Interrupt Map): These bits indicate which INTx signal line the interrupt is routed to. The values 0 - 3 maps the interrupts to INTA_ - INTD_ respectively.

IACKM (Interrupt Acknowledge Interrupt Map): These bits indicate which INTx signal line the interrupt is routed to. The values 0 - 3 maps the interrupts to INTA_ - INTD_ respectively.

SYSFLM (System Fail Interrupt Map): These bits indicate which INTx signal line the interrupt is routed to. The values 0 - 3 maps the interrupts to INTA_ - INTD_ respectively.

ACFLM (AC Fail Interrupt Map): These bits indicate which INTx signal line the interrupt is routed to. The values 0 - 3 maps the interrupts to INTA_ - INTD_ respectively.

IRQ7M (IRQ7 Map): These bits indicate which INTx signal line the interrupt is routed to. The values 0 - 3 maps the interrupts to INTA_ - INTD_ respectively.

IRQ6M (IRQ6 Map): These bits indicate which INTx signal line the interrupt is routed to. The values 0 - 3 maps the interrupts to INTA_ - INTD_ respectively.

IRQ5M (IRQ5 Map): These bits indicate which INTx signal line the interrupt is routed to. The values 0 - 3 maps the interrupts to INTA_ - INTD_ respectively.

IRQ4M (IRQ4 Map): These bits indicate which INTx signal line the interrupt is routed to. The values 0 - 3 maps the interrupts to INTA_ - INTD_ respectively.

IRQ3M (IRQ3 Map): These bits indicate which INTx signal line the interrupt is routed to. The values 0 - 3 maps the interrupts to INTA_ - INTD_ respectively.

IRQ2M (IRQ2 Map): These bits indicate which INTx signal line the interrupt is routed to. The values 0 - 3 maps the interrupts to INTA_ - INTD_ respectively.

IRQ1M (IRQ1 Map): These bits indicate which INTx signal line the interrupt is routed to. The values 0 - 3 maps the interrupts to INTA_ - INTD_ respectively.

10.4.76 DMA Control (0-1) Registers

The DMA Control Register (DCTLx) provides the control fields for the DMA function.

Table 135: DMA Control (0-1) Register

Register Name: DCTLx Reset Value: 0x00000000				Register Offset: DCTL0: CRG + 0x500 DCTL1: CRG + 0x580				
Bits	7	6	5	4	3	2	1	0
31:24	Reserved			ABT	PAU	DGO	Reserved	
23:16	MOD	Reserved				VFAR	PFAR	
15:8	Reserved	VBKS		Reserved	VBOT			
7:0	Reserved	PBKS		Reserved	PBOT			

DMA Control (0-1) Register

Bits	Name	Function	PCFS Space Type	Reset By	Reset Value
31:28	Reserved	N/A	R	N/A	0x00
27	ABT	Abort	R/S	P/S/L	0x00
26	PAU	Pause	R/S	P/S/L	0x00
25	DGO	DMA Go	R/S	P/S/L	0x00
24	Reserved	N/A	R	N/A	0x00
23	MOD	Mode	R/W	P/S/L	0x00
22:18	Reserved	N/A	R	N/A	0x00
17	VFAR	VME Flush on Aborted Read	R/W	P/S/L	0x00
16	PFAR	PCI/X Flush on Aborted Read	R/W	P/S/L	0x00
15	Reserved	N/A	R	N/A	0x00
14:12	VBKS	VMEbus Block Size	R/W	P/S/L	0x00
11	Reserved	N/A	R	N/A	0x00
10:8	VBOT	VMEbus Back-off Timer	R/W	P/S/L	0x00
7	Reserved	N/A	R	N/A	0x00
6:4	PBKS	PCI/X Block Size	R/W	P/S/L	0x00

DMA Control (0-1) Register

Bits	Name	Function	PCFS Space Type	Reset By	Reset Value
3	Reserved	N/A	R	N/A	0x00
2:0	PBOT	PCI/X Back-off Timer	R/W	P/S/L	0x00

ABT (Abort): Writing a one to this field aborts a DMA transaction. An abort is considered an unrecoverable operation to a DMA transaction, meaning that an aborted transaction may not be restarted. When issuing an abort, both the PCI/X and/or VMEbus masters are immediately stopped and all FIFO contents are invalidated. Once the abort has taken affect, the DSTA BSY bit is cleared and the DON and ERR bits is set. Reading this field always returns a zero.

PAU (Pause): Writing a one to this field pauses a DMA transaction. This bit is only applicable to Linked-List-Mode transactions. When pausing a DMA transaction, the DMA controller stops at the completion of the current linked-list transfer. If the pause took affect before the completion of a transaction, then the DTSA. The PAU field is set once the DMA Controller reaches the paused state. A paused transaction may be restarted by writing a one to the DGO field. Reading this field always returns a zero.



Abort (ABT) has authority over Pause (PAU). If a commanded pause is followed by an commanded abort, then the DMA controller honors the commanded abort.

DGO (DMA Go): Writing a one to this field starts a DMA transaction. Reading this field always returns a zero.

MOD (Mode): This bit establishes the type of DMA transaction to be performed. If set, a Direct-Mode transaction is performed. A Direct-Mode transaction performs one transfer according to the contents of the DSAD, DSAT, DDAD, DDAT, and DCNT registers. If cleared, a Linked-List-Mode transaction is performed. A Linked-List-Mode transaction performs multiple transfers that are driven by a list of descriptors stored in PCI/X memory space. A Linked-List-Mode transaction obtains the first descriptor from the starting address placed within the DNLA register.

VFAR (VME Flush on Aborted Read): If this bit is set and a VMEbus cycle is terminated with an exception, any data remaining in the FIFO is transferred to the destination. If this bit is cleared and a VMEbus cycle is terminated with an exception, any data remaining in the DMA FIFO is discarded.

PFAR (PCI/X Flush on Aborted Read): If this bit is set and a PCI/X bus cycle is terminated with an exception, any data remaining in the FIFO is transferred to the destination. If this bit is cleared and a PCI/X bus cycle is terminated with an exception, any data remaining in the DMA FIFO is discarded.

VBKS (VMEbus Block Size): This field is used to control the VMEbus block size when the source is the VMEbus. The encoding of this field is shown in [Table 136](#)

Table 136: DCTL BKS Encoding

VBKS	Transfer Size (bytes)
000b	32
001b	64
010b	128
011b	256
100b	512
101b	1024
110b	2048
111b	4096

VBOT (VMEbus Back-off Timer): The back-off timer determines how long the DMA controller waits before requesting the next block of data. This field controls the internal data flow between the DMA controller and the VME Master Module. The DMA does not attempt to read the next block until after the Back-off Timer has expired. To control the amount of time the VME Master is allowed to spend on the bus during DMA transfers please see the VME Master Control Register ([Table 10.4.34 on page 257](#)).

Table 137 shows the encoding for this field.

Table 137: DCTL VBOT Encoding

VBOT	Back-off Time
000b	0 μ s
001b	1 μ s
010b	2 μ s
011b	4 μ s
100b	8 μ s
101b	16 μ s
110b	32 μ s
111b	64 μ s

PBKS (PCI/X Block Size): This field is used to control the PCI/X bus block size when the source is the PCI/X bus. The encoding of this field is shown in **Table 138**.

Table 138: DCTL PBKS Encoding

PBKS	Transfer Size
	Bytes
000b	32
001b	64
010b	128
011b	256
100b	512
101b	1024
110b	2048
111b	4096

PBOT (PCI/X Back-off Timer): The back-off timer determines how long the DMA waits before requesting the next block of data. This field controls the internal data flow between the DMA controller and the PCI/X Master. The DMA does not attempt to read the next block until after the Back-off Timer has expired.

Table 139 shows the encoding for this field.

Table 139: DCTL PBOT Encoding

PBOT	Back-off Time
000b	0 μ s
001b	1 μ s
010b	2 μ s
011b	4 μ s
100b	8 μ s
101b	16 μ s
110b	32 μ s
111b	64 μ s

10.4.77 DMA Status (0-1) Registers

The DMA Status Register (DSTA) provides the status fields for the DMA function. The BSY field represents the current state of the DMA controller, and the remaining fields indicate completion status. When the DMA controller is starting a transaction (that is, the DGO field is set) the BSY field is asserted and all of the completion status fields are cleared. The BSY field remains asserted and the completion status fields remain cleared throughout the entire DMA transaction. Once the DMA Controller is finished, then the BSY field is cleared and only one of the completion status fields (DON, PAU, ABT, or ERR) is asserted. A functional interrupt is sent to the Exception module whenever the BSY field transitions to the deasserted state.

The completion status fields are prioritized from left to right, with the left most status field holding the highest priority. For example, if the DMA Controller incurs a simultaneous ERR error and an ABT, then the DSTA register only reflects the ERR completion status.

If the DMA Controller incurs multiple errors that are NOT simultaneously detected, then the DSTA register only reflects the status pertaining to the first occurring error. This is of particular importance to the PAU and ABT fields. If an error is detected before the pause or abort takes affect, then the DSTA register only reflects the status pertaining to the error.

Table 140: DMA Status (0-1) Register

Register Name: DSTAx Reset Value: 0x00000000				Register Offset: DCSTA0: CRG + 0x504 DCSTA1: CRG + 0x584				
Bits	7	6	5	4	3	2	1	0
31:24	Reserved			ERR	ABT	PAU	DON	BSY
23:16	Reserved			ERRS	Reserved		ERT1	ERT0
15:8	Reserved							
7:0	Reserved							

DMA Status (0-1) Register

Bits	Name	Function	PCFS Space Type	Reset By	Reset Value
31:29	Reserved	N/A	R	N/A	0x00
28	ERR	Error	R	P/S/L	0x00
27	ABT	Abort	R	P/S/L	0x00
26	PAU	Pause	R	P/S/L	0x00

DMA Status (0-1) Register

Bits	Name	Function	PCFS Space Type	Reset By	Reset Value
25	DON	Done	R	P/S/L	0x00
24	BSY	Busy	R	P/S/L	0x00
23:21	Reserved	N/A	R	N/A	0x00
20	ERRS	Error Source	R	P/S/L	0x00
19:18	Reserved	N/A	R	N/A	0x00
17	ERT1	Error Type	R	P/S/L	0x00
16	ERT0	Error Type	R	P/S/L	0x00
15:0	Reserved	N/A	R	N/A	0x00

ERR (Error): This read-only field is set if the DMA Controller receives an error signal from the PCI/X bus or VMEbus. Additional information is provided in the ERRS and ERT fields.

ABT (Abort): This read-only field is set if the DMA Controller has successfully completed a commanded abort. A successful command abort must meet the following criteria:

1. A write of a logic 1 to the ABT field.
2. The DMA Controller has not received any other errors (ERR) between the time the transaction was started and the time that the DMA Controller goes to the idle state.
3. The commanded abort took place before the DMA Controller was able to complete a transaction.

PAU (Pause): This read-only field is set if the DMA Controller has successfully completed a commanded pause. A successful command pause must meet the following criteria:

1. A write of a logic 1 to the PAU field.
2. The DMA Controller has not received any other errors (ERR) between the time the transaction was started and the time that the DMA Controller goes to the idle state.
3. The DMA Controller has not been issued a commanded abort.
4. The commanded pause took place before the DMA Controller was able to complete a transaction.

DON (Done): This read-only field is set if the DMA Controller has successfully completed a DMA transaction. A successful transaction must meet the following criteria:

1. The DMA Controller has not received any other errors (ERR) between the time the transaction was started and the time that the DMA Controller goes to the idle state.
2. If a commanded abort was issued, then it did not take affect before the transaction was completed.
3. If a commanded pause was issued, then it did not take affect before the transaction was completed.

BSY (Busy): This read-only field reflects the status of the DMA Controller. If set, the DMA Controller is currently processing a DMA transaction. If cleared, the DMA Controller has completed a previous transaction and is now idle.

ERRS (Error Source): When the ERR bit is set, this bit indicates the source of the error. When this bit is set, the PCI/X bus was the source of the error. When this bit is clear, the VMEbus was the source of the error.

ERT (Error Type): When the ERR bit is set, these bits indicate the type of error received.

Table 141: DSTA ERT Encoding

ERRS	ERT	Error Type
0	00b	Bus error: SCT, BLT, MBLT, 2eVME even data, 2eSST
0	01b	Bus error: 2eVME odd data
0	10b	Slave termination: 2eVME even data, 2eSST read
0	11b	Slave termination: 2eVME odd data, 2eSST read last word invalid
1	00b	PCI/X Bus Error
1	01b	Reserved
1	10b	Reserved
1	11b	Reserved

10.4.78 DMA Current Source Address Upper (0-1) Registers

This is a read-only register that contains the upper bits (63:32) of the current source address for a DMA transfer. If the source is VMEbus space, then this field represents a VMEbus address. If the source is PCI/X space, then this field represents a PCI/X address. Software can read this register after a DMA error to determine how far along a DMA transfer went before the error occurred.

If VMEbus error occurs during a FIFO fill, with the VMEbus as the transfer source, this register represents the VMEbus address at which a read error occurred. If a PCI/X bus error occurs during a FIFO fill, with the PCI/X bus as the transfer source, this register represents the PCI/X address at which a read error occurred.

Table 142: DMA Current Source Address Upper (0-1) Register

Register Name: DCSAUx Reset Value: 0x00000000				Register Offset: DCSAU0: CRG + 0x508 DCSAU1: CRG + 0x588				
Bits	7	6	5	4	3	2	1	0
31:0	DCSAUx							

DMA Current Source Address Upper (0-1) Register

Bits	Name	Function	PCFS Space Type	Reset By	Reset Value
31:0	DCSAUx	DMA Current Source Address Upper	R	P/S/L	0x00

10.4.79 DMA Current Source Address Lower (0-1) Registers

This is a read-only register that contains the lower bits (31:0) of the current source address for a DMA transfer. If the source is VMEbus space, then this field represents a VMEbus address. If the source is PCI/X space, then this field represents a PCI/X address. Software can read this register after a DMA error to determine how far along a DMA transfer went before the error occurred.

If a VMEbus error occurs during a FIFO fill, with the VMEbus as the transfer source, this register represents the VMEbus address at which a read error occurred. If a PCI/X bus error occurs during a FIFO fill, with the PCI/X bus as the transfer source, this register represents the PCI/X address at which a read error occurred.

Table 143: DMA Current Source Address Lower (0-1) Register

Register Name: DCSALx Reset Value: 0x00000000				Register Offset: DCSAL0: CRG + 0x50C DCSAL1: CRG + 0x58C				
Bits	7	6	5	4	3	2	1	0
31:0	DCSALx							

DMA Current Source Address Upper (0-1) Register

Bits	Name	Function	PCFS Space Type	Reset By	Reset Value
31:0	DCSALx	DMA Current Source Address Lower	R	P/S/L	0x00

10.4.80 DMA Current Destination Address Upper (0-1) Registers

This is a read-only register that contains the upper bits (63:32) of the current destination address for a DMA transfer. If the destination is VMEbus space, then this field represents a VMEbus address. If the destination is PCI/X space, then this field represents a PCI/X address. Software can read this register after a DMA error to determine how far along a DMA transfer went before the error occurred.

If a VMEbus error occurs during a FIFO empty, with the VMEbus as the transfer destination, this register represents the VMEbus address at which a read error occurred. If a PCI/X bus error occurs during a FIFO empty, with the PCI/X bus as the transfer destination, this register represents the PCI/X address at which a read error occurred.

Table 144: DMA Current Destination Address Upper (0-1) Register

Register Name: DCDAUx Reset Value: 0x00000000				Register Offset: DCDAU0: CRG + 0x510 DCDAU1: CRG + 0x590				
Bits	7	6	5	4	3	2	1	0
31:0	DCDAUx							

DMA Current Destination Upper (0-1) Register

Bits	Name	Function	PCFS Space Type	Reset By	Reset Value
31:0	DCDAUx	DMA Current Destination Address Upper	R	P/S/L	0x00

10.4.81 DMA Current Destination Address Lower (0-1) Registers

This is a read-only register that contains the lower bits (31:0) of the current destination address for a DMA transfer. If the destination is VMEbus space, then this field represents a VMEbus address. If the destination is PCI/X space, then this field represents a PCI/X address. Software can read this register after a DMA error to determine how far along a DMA transfer went before the error occurred.

If a VMEbus error occurs during a FIFO empty, with the VMEbus as the transfer destination, this register represents the VMEbus address at which a write error occurred. If a PCI/X bus error occurs during a FIFO empty, with the PCI/X bus as the transfer destination, this register represents the PCI/X address at which a write error occurred.

Table 145: DMA Current Destination Address Lower (0-1) Register

Register Name: DCDALx Reset Value: 0x00000000				Register Offset: DCDAL0: CRG + 0x514 DCDAL1: CRG + 0x594				
Bits	7	6	5	4	3	2	1	0
31:0	DCDALx							

DMA Current Destination Address Lower (0-1) Register

Bits	Name	Function	PCFS Space Type	Reset By	Reset Value
31:0	DCDALx	DMA Current Destination Address Lower	R	P/S/L	0x00

10.4.82 DMA Current Link Address Upper (0-1) Registers

This is a read-only register that contains the upper bits (63:32) of the current Linked-List-Mode descriptor address for a DMA command. This always represents a PCI/X address. Software can read this register after a DMA error to determine which command in the linked list was being executed when the error occurred.

Table 146: DMA Current Link Address Upper (0-1) Register

Register Name: DCLAUx Reset Value: 0x00000000				Register Offset: DCLAU0: CRG + 0x518 DCLAU1: CRG + 0x598				
Bits	7	6	5	4	3	2	1	0
31:0	DCLAUx							

DMA Current Link Address Upper (0-1) Register

Bits	Name	Function	PCFS Space Type	Reset By	Reset Value
31:0	DCLAUx	DMA Current Link Address Upper	R	P/S/L	0x00

10.4.83 DMA Current Link Address Lower (0-1) Registers

This is a read-only register that contains the lower bits (31:6) of the current Linked-List-Mode descriptor address for a DMA command. This always represents a PCI/X address. Software can read this register after a DMA error to determine which command in the linked list was being executed when the error occurred.

Table 147: DMA Current Link Address Lower (0-1) Register

Register Name: DCLALx Reset Value: 0x00000000				Register Offset: DCLAL0: CRG + 0x51C DCLAL1: CRG + 0x59C				
Bits	7	6	5	4	3	2	1	0
31:24	DCLALx							
23:16	DCLALx							
15:8	DCLALx							
7:0	DCLALx		Reserved					

DMA Current Link Address Lower (0-1) Register

Bits	Name	Function	PCFS Space Type	Reset By	Reset Value
31:6	DCLALx	DMA Current Link Address Lower	R	P/S/L	0x00
5:0	Reserved	N/A	R	N/A	0x00

10.4.84 DMA Source Address Upper (0-1) Registers

This register contains the upper bits (63:32) of the source address for a DMA transfer. If the source is VMEbus space then this field represents a VMEbus address. If the source is PCI/X space then this field represents a PCI/X address.

Software programs this register when performing Direct-Mode transactions. When performing Linked-List-Mode transactions, this register is automatically loaded from the source address field of the current descriptor.

Table 148: DMA Source Address Upper (0-1) Register

Register Name: DSAUx Reset Value: 0x00000000				Register Offset: DSAU0: CRG + 0x520 DSAU1: CRG + 0x5A0				
Bits	7	6	5	4	3	2	1	0
31:0	DSAUx							

DMA Source Address Upper (0-1) Register

Bits	Name	Function	PCFS Space Type	Reset By	Reset Value
31:0	DSAUx	DMA Source Address Upper	R/W	P/S/L	0x00

10.4.85 DMA Source Address Lower (0-1) Registers

This register contains the lower bits (31:0) of the source address for a DMA transfer. If the source is VMEbus space then this field represents a VMEbus address. If the source is PCI/X space then this field represents a PCI/X address.

Software programs this register when performing Direct-Mode transactions. When performing Linked-List-Mode transactions, this register is automatically loaded from the source address field of the current descriptor.

Table 149: DMA Source Address Lower (0-1) Register

Register Name: DCALx Reset Value: 0x00000000	Register Offset: DSAL0: CRG + 0x524 DSAL1: CRG + 0x5A4
---	---

Bits	7	6	5	4	3	2	1	0
31:0	DSALx							

DMA Source Address Lower (0-1) Register

Bits	Name	Function	PCFS Space Type	Reset By	Reset Value
31:0	DSALx	DMA Source Address Lower	R/W	P/S/L	0x00

10.4.86 DMA Destination Address Upper (0-1) Registers

This register contains the upper bits (63:32) of the destination address for a DMA transfer. If the destination is VMEbus space then this field represents a VMEbus address. If the destination is PCI/X space then this field represents a PCI/X address.

Software programs this register when performing Direct-Mode transactions. When performing Linked-List-Mode transactions, this register is automatically loaded from the destination address field of the current descriptor.

Table 150: DMA Destination Address Upper (0-1) Register

Register Name: DDAUx Reset Value: 0x00000000				Register Offset: DDAUx: CRG + 0x528 DDAUx: CRG + 0x5A8				
Bits	7	6	5	4	3	2	1	0
31:0	DDAU							

DMA Destination Address Upper (0-1) Register

Bits	Name	Function	PCFS Space Type	Reset By	Reset Value
31:0	DDAUx	DMA Destination Address Upper	R/W	P/S/L	0x00

10.4.87 DMA Destination Address Lower (0-1) Registers

This register contains the lower bits (31:0) of the destination address for a DMA transfer. If the destination is VMEbus space then this field represents a VMEbus address. If the destination is PCI/X space then this field represents a PCI/X address.

Software programs this register when performing Direct-Mode transactions. When performing Linked-List-Mode transactions, this register is automatically loaded from the destination address field of the current descriptor.

Table 151: DMA Destination Address Lower (0-1) Register

Register Name: DDALx Reset Value: 0x00000000	Register Offset: DDALx: CRG + 0x52C DDALx: CRG + 0x5AC
---	--

Bits	7	6	5	4	3	2	1	0
31:0	DDAL							

DMA Destination Address Lower (0-1) Register

Bits	Name	Function	PCFS Space Type	Reset By	Reset Value
31:0	DDAL	DMA Destination Address Lower	R/W	P/S/L	0x00

10.4.88 DMA Source Attribute (0-1) Registers

The DMA Source Attribute Register (DSAT) contains the source attributes for a DMA transfer. Not all fields are used for all transfer types. Fields that do not pertain to a particular transfer type are ignored.

Software programs this register when performing Direct-Mode transactions. When performing Linked-List-Mode transactions, this register is automatically loaded from the source attribute field of the current descriptor.

Table 152: DMA Source Attribute (0-1) Register

Register Name: DSATx Reset Value: 0x00000000				Register Offset: DSAT0: CRG + 0x530 DSAT1: CRG + 0x5B0				
Bits	7	6	5	4	3	2	1	0
31:24	Reserved		TYP1	TYP0	Reserved		PSZ	NIP
23:16	Reserved							
15:8	Reserved			SSTM1	SSTM0	TM2	TM1	TM0
7:0	DBW1	DBW0	SUP	PGM	AMODE3	AMODE2	AMODE1	AMODE0

DMA Source Attribute (0-1) Register

Bits	Name	Function	PCFS Space Type	Reset By	Reset Value
31:30	Reserved	N/A	R	N/A	0x00
29	TYP1	Type	R/W	P/S/L	0x00
28	TYP0	Type	R/W	P/S/L	0x00
27:26	Reserved	N/A	R	N/A	0x00
25	PSZ	Pattern Size	R/W	P/S/L	0x00
24	NIP	No Increment Pattern	R/W	P/S/L	0x00
23:13	Reserved	N/A	R	N/A	0x00
12	SSTM1	2eSST Mode	R/W	P/S/L	0x00
11	SSTM0	2eSST Mode	R/W	P/S/L	0x00
10	TM2	Transfer Mode	R/W	P/S/L	0x00
9	TM1	Transfer Mode	R/W	P/S/L	0x00

DMA Source Attribute (0-1) Register

Bits	Name	Function	PCFS Space Type	Reset By	Reset Value
8	TM0	Transfer Mode	R/W	P/S/L	0x00
7	DBW1	VMEbus Data Bus Width	R/W	P/S/L	0x00
6	DBW0	VMEbus Data Bus Width	R/W	P/S/L	0x00
5	SUP	VMEbus Supervisory Mode	R/W	P/S/L	0x00
4	PGM	VMEbus Program Mode	R/W	P/S/L	0x00
3	AMODE3	Address Mode	R/W	P/S/L	0x00
2	AMODE2	Address Mode	R/W	P/S/L	0x00
1	AMODE1	Address Mode	R/W	P/S/L	0x00
0	AMODE0	Address Mode	R/W	P/S/L	0x00

TYP (Type): This field indicates the type of source to be used for a DMA transfer. Different fields within the **DSAT** register are used depending on the type of source selected. [Table 153](#) shows the different source types and the associated fields within the **DSAT** register that apply.

Table 153: DSAT TYP Encoding

TYP	DMA Source	Applicable Fields							
		NIP	PSZ	SSTM	TM	DBW	SUP	PGM	AMODE
00b	PCI/X bus								
01b	VMEbus			X	X	X	X	X	X
1xb	Data Pattern	X	X						

PSZ (Pattern Size): If set, the data size used during Data Pattern transfers is bytes (8-bit). If cleared, the data size is words (32-bit). This field only applies to the generation of the data patterns used for a transfer. It does not specify how the patterns are actually placed into the destination space. (that is, selecting a byte pattern size does not result in a stream of single-beat bus cycles.)

NIP (No Increment Pattern): If set, and the source is a data pattern, then the data pattern, will not be incremented. If cleared and the source is a data pattern, the data pattern will be incremented.

SSTM (2eSST Mode): This field defines the 2eSST Transfer Rate.

Table 154: 2eSST Transfer Rate

SSTM	Transfer Rate
00b	160 MB/s
01b	267 MB/s
10b	320 MB/s
11b	Reserved

TM (Transfer Mode): This field defines the VMEbus transfer mode.

Table 155: VMEbus Transfer Mode

TM	Transfer Mode
000b	SCT
001b	BLT
010b	MBLT
011b	2eVME
100b	2eSST
101b	2eSST Broadcast
110b	Reserved
111b	Reserved

DBW (VMEbus Data Bus Width): These bits define the maximum data bus width for VMEbus transfers initiated by the DMA controller. These bits apply to SCT and BLT transfers. MBLT, 2eVME and 2eSST transfers are always 64-bit.

Table 156: VMEbus Data Bus Width

DWB	Data Bus Width
00b	16 bit
01b	32 bit
10b	Reserved
11b	Reserved

SUP (VMEbus Supervisory Mode): When this bit is set the AM code indicates Supervisory Access. When this bit is cleared the AM code indicates Non-Privileged Access.

PGM (VMEbus Program Mode): When this bit is set the AM code indicates Program Access. When this bit is cleared the AM code indicates Data Access.

AMODE (Address Mode): This field defines the VMEbus Address mode.

Table 157: VMEbus Address Mode

AMODE	Address Mode
0000b	A16
0001b	A24
0010b	A32
0011b	Reserved
0100b	A64
0101b	CR/CSR
0110b	Reserved
0111b	Reserved
1000b	User1 (AM 0100xxb)
1001b	User2 (AM 0101xxb)
1010b	User3 (AM 0110xxb)
1011b	User4 (AM 0111xxb)
1100b	Reserved
1101b	Reserved
1110b	Reserved
1111b	Reserved

When the User1-User4 modes are used, the AM[1] bit is defined by the SUP bit and the AM[0] bit is defined by the PGM bit.

10.4.89 DMA Destination Attribute (0-1) Registers

The DMA Destination Attribute Register (DDAT) contains the destination attributes for a DMA transfer. Not all fields are used for all transfer types. Fields that do not pertain to a particular transfer type are ignored.

Software programs this register when performing Direct-Mode transactions. When performing Linked-List-Mode transactions, this register is automatically loaded from the destination attribute field of the current descriptor.

Table 158: DMA Destination Attribute (0-1) Register

Register Name: DDATx Reset Value: 0x00000000				Register Offset: DDATx: CRG + 0x534 DDATx: CRG + 0x5B4				
Bits	7	6	5	4	3	2	1	0
31:24	Reserved			TYP	Reserved			
23:16	Reserved							
15:8	Reserved			SSTM1	SSTM0	TM2	TM1	TM0
7:0	DBW1	DBW0	SUP	PGM	AMODE3	AMODE2	AMODE1	AMODE0

DMA Destination Attribute (0-1) Register

Bits	Name	Function	PCFS Space Type	Reset By	Reset Value
31:29	Reserved	N/A	R	N/A	0x00
28	TYP	Type	R/W	P/S/L	0x00
27:13	Reserved	N/A	R	N/A	0x00
12	SSTM1	2eSST Mode	R/W	P/S/L	0x00
11	SSTM0	2eSST Mode	R/W	P/S/L	0x00
10	TM2	Transfer Mode	R/W	P/S/L	0x00
9	TM1	Transfer Mode	R/W	P/S/L	0x00
8	TM0	Transfer Mode	R/W	P/S/L	0x00
7	DBW1	VMEbus Data Bus Width	R/W	P/S/L	0x00
6	DBW0	VMEbus Data Bus Width	R/W	P/S/L	0x00
5	SUP	VMEbus Supervisory Mode	R/W	P/S/L	0x00

DMA Destination Attribute (0-1) Register

Bits	Name	Function	PCFS Space Type	Reset By	Reset Value
4	PGM	VMEbus Program Mode	R/W	P/S/L	0x00
3	AMODE3	Address Mode	R/W	P/S/L	0x00
2	AMODE2	Address Mode	R/W	P/S/L	0x00
1	AMODE1	Address Mode	R/W	P/S/L	0x00
0	AMODE0	Address Mode	R/W	P/S/L	0x00

TYP (Type): This field indicates the type of destination to be used for a DMA transfer. Different fields within the DDAT register are used depending on the type of destination selected. **Table 159** shows the different destination types and the associated fields within the DDAT register that apply.

Table 159: DDAT TYP Encoding

TYP	DMA Destination	Applicable Fields					
		SSTM	TM	DBW	SUP	PGM	AMODE
0	PCI/X bus						
1	VMEbus	X	X	X	X	X	X

SSTM (2eSST Mode): This field defines the 2eSST Transfer Rate.

Table 160: 2eSST Transfer Rate

SSTM	Transfer Rate
00b	160 MB/s
01b	267 MB/s
10b	320 MB/s
11b	Reserved

TM (Transfer Mode): This field defines the VMEbus transfer mode.

Table 161: VMEbus Transfer Mode

TM	Transfer Mode
000b	SCT
001b	BLT
010b	MBLT
011b	2eVME
100b	2eSST
101b	Reserved
110b	Reserved
111b	Reserved

DBW (VMEbus Data Bus Width): These bits define the maximum data bus width for VMEbus transfers initiated by the DMA controller.

Table 162: VMEbus Data Bus Width

DWB	Data Bus Width
00b	16 bit
01b	32 bit
10b	Reserved
11b	Reserved

SUP (VMEbus Supervisory Mode): When this bit is set the AM code indicates Supervisory Access. When this bit is cleared the AM code indicates Non-Privileged Access.

PGM (VMEbus Program Mode): When this bit is set the AM code indicates Program Access. When this bit is cleared the AM code indicates Data Access.

AMODE (Address Mode): This field defines the VMEbus Address mode.

Table 163: VMEbus Address Mode

AMODE	Address Mode
0000b	A16
0001b	A24
0010b	A32
0011b	Reserved
0100b	A64
0101b	CR/CSR
0110b	Reserved
0111b	Reserved
1000b	User1 (AM 0100xxb)
1001b	User2 (AM 0101xxb)
1010b	User3 (AM0110xxb)
1011b	User4 (AM 0111xxb)
1100b	Reserved
1101b	Reserved
1110b	Reserved
1111b	Reserved

When the User1-User4 modes are used, the AM[1] bit is defined by the SUP bit and the AM[0] bit is defined by the PGM bit.

10.4.90 DMA Next Link Address Upper (0-1) Registers

These are the upper address bits (63:32) of the next descriptor when using Linked-List-Mode. This is a PCI/X address.

This register is not used when performing Direct-Mode transactions. When starting a Linked-List-Mode transaction, software programs this register with the address of the first Linked-List-Mode descriptor. When continuing a Linked-List-Mode transaction, the register is automatically loaded from the next link address field of the current descriptor.

Table 164: DMA Next Link Address Upper (0-1) Register

Register Name: DNLAUx Reset Value: 0x00000000				Register Offset: DNLAUx: CRG + 0x538 DNLAUx: CRG + 0x5B8				
Bits	7	6	5	4	3	2	1	0
31:0	DNLAU							

DMA Next Link Address Upper (0-1) Register

Bits	Name	Function	PCFS Space Type	Reset By	Reset Value
31:0	DNLAU	DMA Next Link Address Upper	R/W	P/S/L	0x00

10.4.91 DMA Next Link Address Lower (0-1) Registers

Table 165: DMA Next Link Address Lower (0-1) Register

Register Name: DNLALx Reset Value: 0x00000000				Register Offset: DNLAL0: CRG + 0x53C DNLAL1: CRG + 0x5BC				
Bits	7	6	5	4	3	2	1	0
31:24	DNLALx							
23:16	DNLALx							
15:8	DNLALx							
7:0	DNLALx					Reserved		LLA

DMA Next Link Address Lower (0-1) Register

Bits	Name	Function	PCFS Space Type	Reset By	Reset Value
31:3	DNLALx	DMA Next Link Address Lower	R/W	P/S/L	0x00
2:1	Reserved	N/A	R	N/A	0x00
0	LLA	Last Link Address	R/W	P/S/L	0x00

DNLAL (DMA Next Link Address Lower): These are the Lower address bits (31:3) of the next descriptor when using Linked-List-Mode. This is a PCI/X address.

This register is not used when performing Direct-Mode transactions. When starting a Linked-List-Mode transaction, software programs this register with the address of the first Linked-List-Mode descriptor. When continuing a Linked-List-Mode transaction, the register is automatically loaded from the next link address field of the current descriptor.

LLA (Last Link Address): If set, the current descriptor is the last descriptor of a Linked-List transaction. If cleared, the current descriptor is not the last descriptor.

10.4.92 DMA Count (0-1) Registers

This register contains the byte count for a DMA transfer. A zero value indicates that zero bytes are transferred. As the DMA transfer progresses, the DCNT register is decremented. When a DMA transfer completes with out errors, the final DCNT value is zero.

Software programs this register when performing Direct-Mode transactions. When performing Linked-List-Mode transactions, this register is automatically loaded from the count field of the current descriptor.

Table 166: DMA Count (0-1) Register

Register Name: DCNTx Reset Value: 0x00000000				Register Offset: DCNTx: CRG + 0x540 DCNTx: CRG + 0x5C0				
Bits	7	6	5	4	3	2	1	0
31:0	DCNTx							

DMA Count (0-1) Register

Bits	Name	Function	PCFS Space Type	Reset By	Reset Value
31:0	DCNT	DMA Count Register	R/W	P/S/L	0x00

10.4.93 DMA Destination Broadcast Select (0-1) Registers

This register contains the 2eSST broadcast select bits. Each bit corresponds to one of the 21 possible slaves. The 2eSST master broadcasts this field during address phase three. Register bit 11 corresponds to VMEbus address line A21 and register bit 31 corresponds to VMEbus address line A1.

Software programs this register when performing Direct-Mode transactions. When performing Linked-List-Mode transactions, this register is automatically loaded from the broadcast select field of the current descriptor.

Table 167: DMA Destination Broadcast Select (0-1) Register

Register Name: DDBSx Reset Value: 0x00000000				Register Offset: DDBSx: CRG + 0x544 DDBSx: CRG + 0x5C4				
Bits	7	6	5	4	3	2	1	0
31:24	Reserved							
23:16	Reserved			DDBS				
15:8	DDBS							
7:0	DDBS							

DMA Destination Broadcast Select (0-1) Register

Bits	Name	Function	PCFS Space Type	Reset By	Reset Value
31:21	Reserved	N/A	R	N/A	0x00
20:0	DDBS	DMA Destination Broadcast Select Register	R/W	P/S/L	0x00

10.4.94 GCSR Register Group

This section defines the Global Control and Status Registers (GCSR). These registers are accessible from the PCI/X bus or VMEbus. The VMEbus address and address space is programmable. RMW cycles from the VMEbus are not guaranteed indivisible.

10.4.95 Vendor ID / Device ID Registers

Table 168: Vendor ID / Device ID Register

Register Name: DEVI/VENI Reset Value: 0x014810E3				Register Offset: GCSR + 0x00 - CRG + 0x600				
Bits	7	6	5	4	3	2	1	0
31:24	DEVI							
23:16	DEVI							
15:8	VENI							
7:0	VENI							

Vendor ID / Device ID Register

Bits	Name	Function	PCFS Space Type	Reset By	Reset Value
31:21	DEVI	Device ID	R	-	0x0148
20:0	VENI	Vendor ID	R	-	0x10E3

DEVI (Device ID): This register is a read only register that uniquely identifies this particular device. The Tsi148 always returns 0x0148.

VENI (Vendor ID): This register is a read-only register that identifies the manufacturer of the device. This identifier is allocated by the PCI/X Special Interest Group to ensure uniqueness. 0x10E3 has been assigned to Motorola and is hard wired as a read-only value.

10.4.96 Control and Status Register

Table 169: Control and Status Register

Register Name: GCTRL Reset Value: 0x				Register Offset: GCSR + 0x04 - CRG + 0x604				
Bits	7	6	5	4	3	2	1	0
31:24	LRST	SFAILEN	BDFAILS	SCONS	MEN	Reserved		
23:16	LMI3S	LMI2S	LMI1S	LMI0S	MBI3S	MBI2S	MBI1S	MBI0S
15:8	Reserved		GAP	GA				
7:0	REVID							

Control and Status Register

Bits	Name	Function	PCFS Space Type	Reset By	Reset Value
31	LRST	Local Reset	R/W	P/S	0x00
30	SFAILEN	System Fail Enable	R/W	P/S	0xxx
29	BDFAILS	Board Fail Status	R	P/S/L	0x01
28	SCONS	System Controller Status	R	P	0xxx
27	MEN	Module Enable	R/W	P/S/L	0x00
26:24	Reserved	N/A	R	N/A	0x00
23	LMI3S	Location Monitor Interrupt 3 Status	R	P/S/L	0x00
22	LMI2S	Location Monitor Interrupt 2 Status	R	P/S/L	0x00
21	LMI1S	Location Monitor Interrupt 1 Status	R	P/S/L	0x00
20	LMI0S	Location Monitor Interrupt 0 Status	R	P/S/L	0x00
19	MBI3S	Mail Box Interrupt 3 Status	R	P/S/L	0x00
18	MBI2S	Mail Box Interrupt 2 Status	R	P/S/L	0x00
17	MBI1S	Mail Box Interrupt 1 Status	R	P/S/L	0x00
16	MBI0S	Mail Box Interrupt 0 Status	R	P/S/L	0x00
15:14	Reserved	N/A	R	N/A	0x00
13	GAP	Geographic Address Parity	R	-	0xxx

Control and Status Register

Bits	Name	Function	PCFS Space Type	Reset By	Reset Value
12:8	GA	Geographic Address	R	-	0xxx
7:0	REVID	Revision ID	R	-	0x01

LRST (Local Reset): When this bit is set, the LRSTO_ signal is asserted. When this bit is cleared, the LRSTO_ signal is not asserted. When this bit is set and cleared, the Tsi148 ensures the minimum pulse width for local reset is met.

SFAILEN (System Fail Enable): When this bit is set and the BDFAIL_ signal is asserted, the SFAILO signal line is asserted. When this bit is cleared, the SFAILO signal line is not asserted. The initial value of this bit is a configuration option.

The system fail enable bit is also accessible in the CR/CSR.

BDFAILS (Board Fail Status): Reading a one indicates the BDFAIL_ signal is asserted. Reading a zero indicates the BDFAIL_ signal is not asserted.

SCONS (System Controller Status): Reading a one indicates, the VMEbus system controller is enabled.

MEN (Module Enable): This is a read/write bit that can be used to indicate a ready condition. The READY is cleared by reset. Software may set this bit, after the board is initialized, to indicate the board is ready.

LMI3S (Location Monitor Interrupt 3 Status): When set, a location monitor 3 interrupt is pending.

LMI2S (Location Monitor Interrupt 2 Status): When set, a location monitor 2 interrupt is pending.

LMI1S (Location Monitor Interrupt 1 Status): When set, a location monitor 1 interrupt is pending.

LMI0S (Location Monitor Interrupt 0 Status): When set, a location monitor 0 interrupt is pending.

MBI3S (Mail Box Interrupt 3 Status): When set, a mail box 3 interrupt is pending.

MBI2S (Mail Box Interrupt 2 Status): When set, a mail box 2 interrupt is pending.

MBI1S (Mail Box Interrupt 1 Status): When set, a mail box 1 interrupt is pending.

MBIOS (Mail Box Interrupt 0 Status): When set, a mail box 0 interrupt is pending.

GAP (Geographic Address Parity): This bit is the parity bit for the Geographic Address. This bit is inverted from the VMEbus GAP* signal.

GA (Geographic Address): These bits represent the Geographic Address of the board. These bits are inverted from the VMEbus GA[4:0]_ signals.

REVID (Revision ID): This register identifies the Tsi148's revision level.

10.4.97 Semaphore Registers (0-3)

Table 170: Semaphore Register (0-3)

Register Name: SEMAR0 Reset Value: 0x00000000				Register Offset: GCSR + 0x08 - CRG + 0x608				
Bits	7	6	5	4	3	2	1	0
31:24	SEMA0							
23:16	SEMA1							
15:8	SEMA2							
7:0	SEMA3							

Semaphore Registers

Bits	Name	Function	PCFS Space Type	Reset By	Reset Value
31:24	SEMA0	Semaphore 0	R/W	P/S	0x00
23:16	SEMA1	Semaphore 1	R/W	P/S	0x00
15:8	SEMA2	Semaphore 2	R/W	P/S	0x00
7:0	SEMA3	Semaphore 3	R/W	P/S	0x00

SEMA0 - SEMA3: A semaphore can only be written if the most significant bit in this field is currently 0 and the most significant bit of the write data is a 1, or the most significant bit of the write data is a 0.

10.4.98 Semaphore Registers (4-7)

Table 171: Semaphore Registers (0-4)

Register Name: SEMAR1 Reset Value: 0x00000000				Register Offset: GCSR + 0x0C - CRG + 0x60C				
Bits	7	6	5	4	3	2	1	0
31:24	SEMA4							
23:16	SEMA5							
15:8	SEMA6							
7:0	SEMA7							

Semaphore Registers

Bits	Name	Function	PCFS Space Type	Reset By	Reset Value
31:24	SEMA4	Semaphore 4	R/W	P/S	0x00
23:16	SEMA5	Semaphore 5	R/W	P/S	0x00
15:8	SEMA6	Semaphore 6	R/W	P/S	0x00
7:0	SEMA7	Semaphore 7	R/W	P/S	0x00

SEMA4 - SEMA7: A semaphore can only be written if the most significant bit in this field is currently 0 and the most significant bit of the write data is a 1, or the most significant bit of the write data is a 0.

10.4.99 Mail Box Registers (0-3)

The mail box register can be used to pass information between the local processor and other VME boards. When the least significant byte is written, an interrupt is sent to the interrupter. If the interrupt is enabled, an INTx signal is generated.

Table 172: Mail Box Registers (0-3)

Register Name: MBOXx Reset Value: 0x00000000	Register Offset: MBOX0: GCSR + 0x10 - CRG + 0x610 MBOX1: GCSR + 0x14 - CRG + 0x614 MBOX2: GCSR + 0x18 - CRG + 0x618 MBOX3: GCSR + 0x1C - CRG + 0x61C
---	---

Bits	7	6	5	4	3	2	1	0
31:0	MBOX							

Mail Box Registers (0-3)

Bits	Name	Function	PCFS Space Type	Reset By	Reset Value
31:0	MBOX	Mail Box	R/W	P/S	0x00

10.4.100 CR/CSR Register Group Description

The Tsi148 implements a sub-set of the CR/CSR register set. This section describes the CSR registers that are included.

10.4.101 CR/CSR Bit Clear Register

Table 173: CR/CSR Bit Clear Register

Register Name: CSRBCR Reset Value: 0x00000000				Register Offset: CR/CSR + 0x7FFF4 - CRG + 0xFF4				
Bits	7	6	5	4	3	2	1	0
31:24	Reserved							
23:16	Reserved							
15:8	Reserved							
7:0	LRSTC	SFAILC	BDFAILS	MENC	BERRSC	Reserved		

CR/CSR Bit Clear Register

Bits	Name	Function	PCFS Space Type	Reset By	Reset Value
31:8	Reserved	N/A	R	N/A	0x00
7	LRSTC	Local Reset Clear	C/R	P/S	0x00
6	SFAILC	System Fail Enable Clear	C/R	P/S	0x00
5	BDFAILS	Board Fail Status	R	P/S/L	0x01
4	MENC	Module Enable Clear	C/R	P/S/L	0x00
3	BERRSC	Bus Error Status Clear	C/R	P/S/L	0x00
2:0	Reserved	N/A	R	N/A	0x00

LRSTC (Local Reset Clear): Writing a one to this bit clears the LRST bit. Reading a one indicates the LRST bit is set. Reading a zero indicates the LRST bit is cleared.

SFAILC (System Fail Enable Clear): Writing a one to this bit disables the SFAILO driver. Reading a one indicates the SFAILO driver is enabled. Reading a zero indicates the SFAILO driver is disabled. The initial value of this bit is a configuration option. The system fail enable bit is also accessible from the GCSR.

BDFAILS (Board Fail Status): Reading a one indicates the BDFAIL_ signal is asserted. Reading a zero indicates the BDFAIL_ signal is not asserted.

MENC (Module Enable Clear): Writing a one to this bit clears the module enable bit. Reading a one indicates the module enable bit is set. Reading a zero indicates the module enable bit is not set. The module enable bit can be used as a ready bit. The module enable bit is also accessible from the GCSR.

BERRSC (Bus Error Status Clear): This bit is set when the Tsi148 asserts the VMEbus BERR* signal. Writing a one to this bit clears the BERR status bit. Reading a one indicates that the Tsi148 has asserted the BERR* signal or that the BERRSS bit has been set. Reading a zero indicates that the Tsi148 has not asserted the BERR* signal and BERRSS bit has not been set.

10.4.102 CR/CSR Bit Set Register

Table 174: CR/CSR Bit Set Register

Register Name: CSRBSR Reset Value: 0x				Register Offset: CR/CSR + 0x7FFF8 - CRG + 0xFF8				
Bits	7	6	5	4	3	2	1	0
31:24	Reserved							
23:16	Reserved							
15:8	Reserved							
7:0	LRSTS	SFAILS	BDFAILS	MENS	BERRSS	Reserved		

CR/CSR Bit Clear Register

Bits	Name	Function	PCFS Space Type	Reset By	Reset Value
31:8	Reserved	N/A	R	N/A	0x00
7	LRSTS	Local Reset Set	S/R	N/A	0x00
6	SFAILS	System Fail Enable Set	S/R	P/S	0xxx
5	BDFAILS	Board Fail Status	R	P/S/L	0x01
4	MENS	Module Enable Set	S/R	P/S/L	0x00
3	BERRSS	Bus Error Status Set	S/R	P/S/L	0x00
2:0	Reserved	N/A	R	N/A	0x00

LRSTS (Local Reset Set): Writing a one to this bit sets the LRST signal. This asserts the LRSTO_ signal and hold the board in reset until a one is written to the LRSTC bit. This bit should only be set from VMEbus. It should not be set from the CRG. Reading a one indicates the LRST bit is set. Reading a zero indicates the LRST bit is cleared.

SFAILS (System Fail Enable Set): Writing a one to this bit enables SFAILO driver. Reading a one indicates the SFAILO driver is enabled. Reading a zero indicates the SFAILO driver is disabled. The initial value of this bit is a configuration option. The system fail enable bit is also accessible from the GCSR.

BDFAILS (Board Fail Status): Reading a one indicates the BDFAIL_ signal is asserted. Reading a zero indicates the BDFAIL_ signal is not asserted.

MENS (Module Enable Set): Writing a one to this bit sets the module enable bit. Reading a one indicates the module enable bit is set. Reading a zero indicates the module enable bit is not set. The module enable bit can be used as a ready bit. The module enable bit is also accessible from the GCSR.

BERRSS (Bus Error Status Set): This bit is set when the Tsi148 asserts the VMEbus BERR* signal. Writing a one to this bit sets the BERR status bit. Reading a one indicates that the Tsi148 has asserted the BERR* signal or that the BERR status bit has been set. Reading a zero indicates that the Tsi148 has not asserted the BERR* signal and BERR status bit has not been set.

10.4.103 CR/CSR Base Address Register

The CBAR is used to select one of the 31 available CR/CSR regions (0x00 is reserved for use in Auto Slot ID). The CBAR values are in the range of 0x01 to 0x1F. Bits 7 to 3 of the CBAR are compared with VMEbus address bits 23 to 19. The initial value of CBAR is determined by the hardware configuration.

Table 175: CR/CSR Base Address Register

Register Name: CBAR Reset Value: 0x00000000				Register Offset: CR/CSR + 0x7FFFC - CRG + 0xFFC				
Bits	7	6	5	4	3	2	1	0
31:24	Reserved							
23:16	Reserved							
15:8	Reserved							
7:0	CBAR					Reserved		

CR/CSR Bit Clear Register

Bits	Name	Function	PCFS Space Type	Reset By	Reset Value
31:8	Reserved	N/A	R	N/A	0x00
7:3	CBAR	CR/CSR Base Address	R/W	P/S	0xxx
2:0	Reserved	N/A	R	N/A	0x00

A. Typical Applications

This appendix discusses typical application information for Tsi148. The following topic is discussed:

- [“Tsi148 Connection Schematics” on page 374](#)

A.1 Overview

This chapter describes the physical, electrical, and connection requirements for a board design using the Tsi148 device.



Information shown in [Figure 38](#) through [Figure 47](#) is board dependent. Some boards may not require the design elements or connections detailed in the schematics.

A.2 Tsi148 Connection Schematics

The schematics shown in [Figure 38](#) through [Figure 47](#) illustrate a typical way Tsi148 can be connected into a system. Individual system requirements may imply the need for alternate configurations. The figures focus on connecting Tsi148 to both the PCI/X and VMEbus, as well as power requirements, pull-up/down usage, and various buffer conventions.



The schematics focus solely on Tsi148 requirements. All other design requirements are up to the individual board designer.

Off-page references are used in these schematics. The title of each schematic includes the page number used in the original schematic so that off-page references can be tracked. For example, in [Figure 38](#), the page number in the original schematic is 38.

In the following schematics the terms NC and OPT are defined as follows:

- NC — no connect
- OPT — optional

[Figure 38](#) shows Tsi148 connected to both the VMEbus and PCI/X bus.



In some instances, the term TEMPE_ precedes signal names in the following schematics. The names of the signals do not use this term and are shown in [“VMEbus Signal Descriptions” on page 161](#).

Figure 38: Tsi148 Schematic (Page 38) - Tsi148 Device

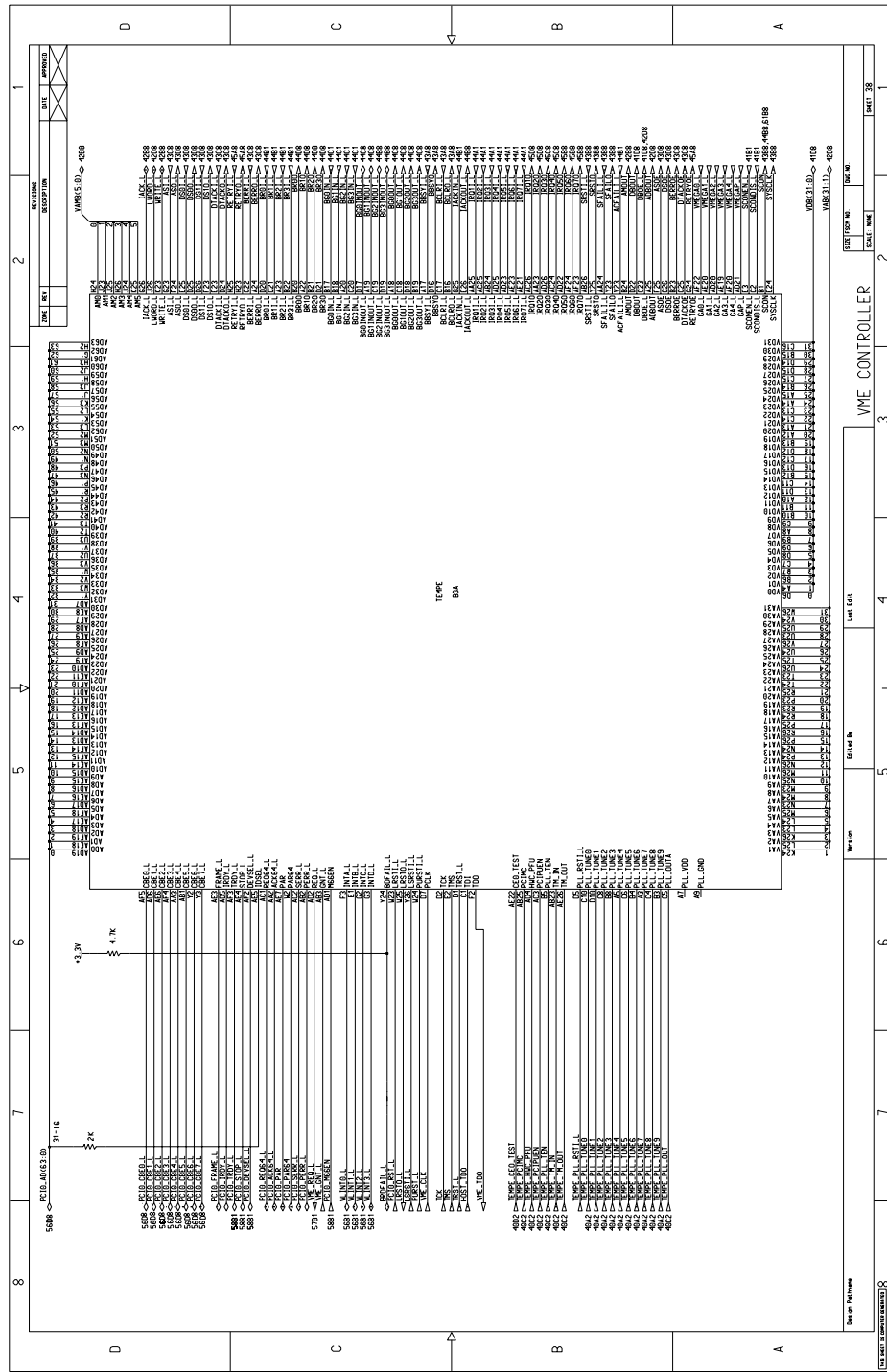

Connect the PLL_VDDA, PLL_GNDA signals to low noise power and ground.

Figure 39: Tsi148 Schematic (Page 39) - Power Pins

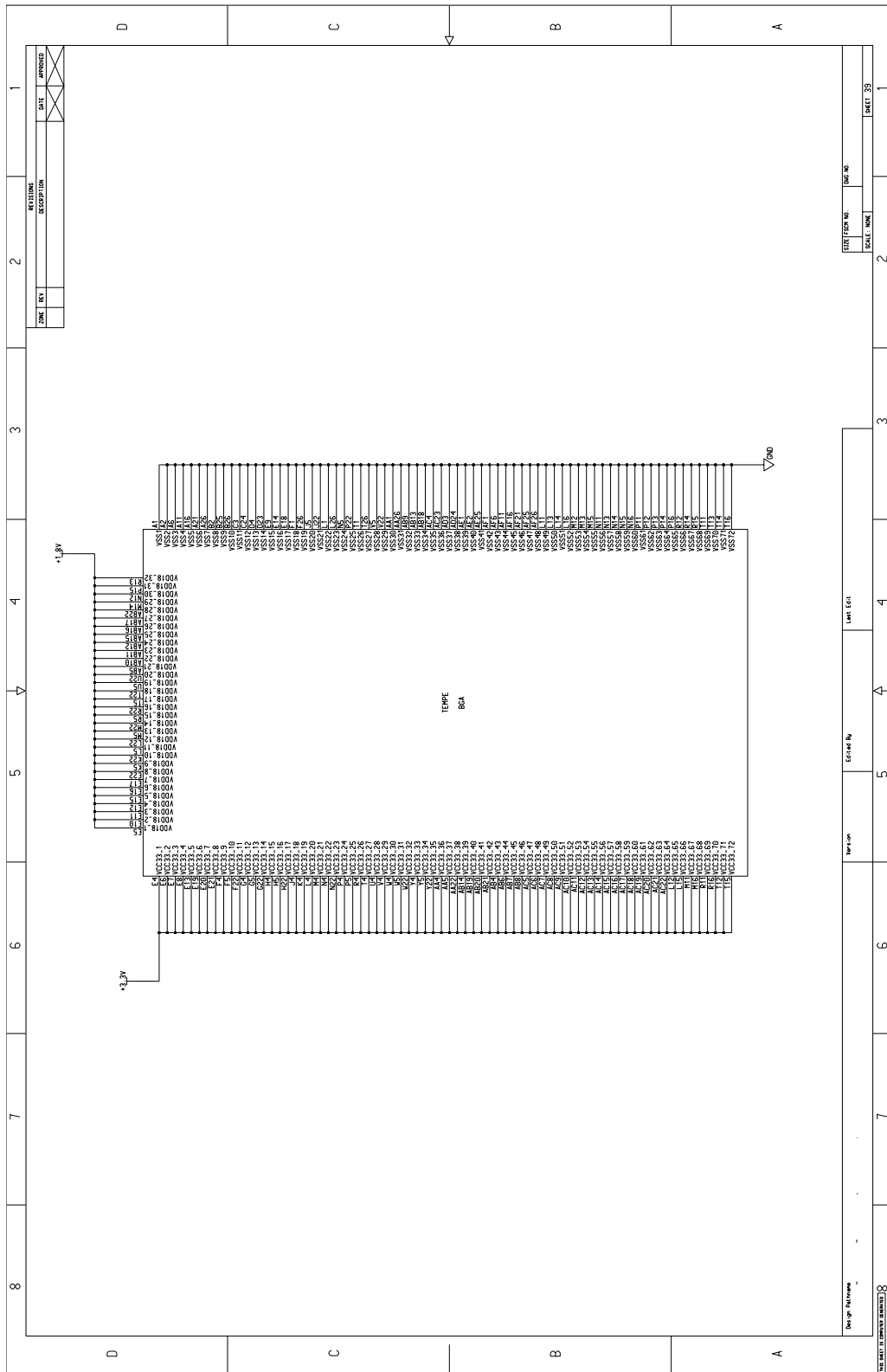
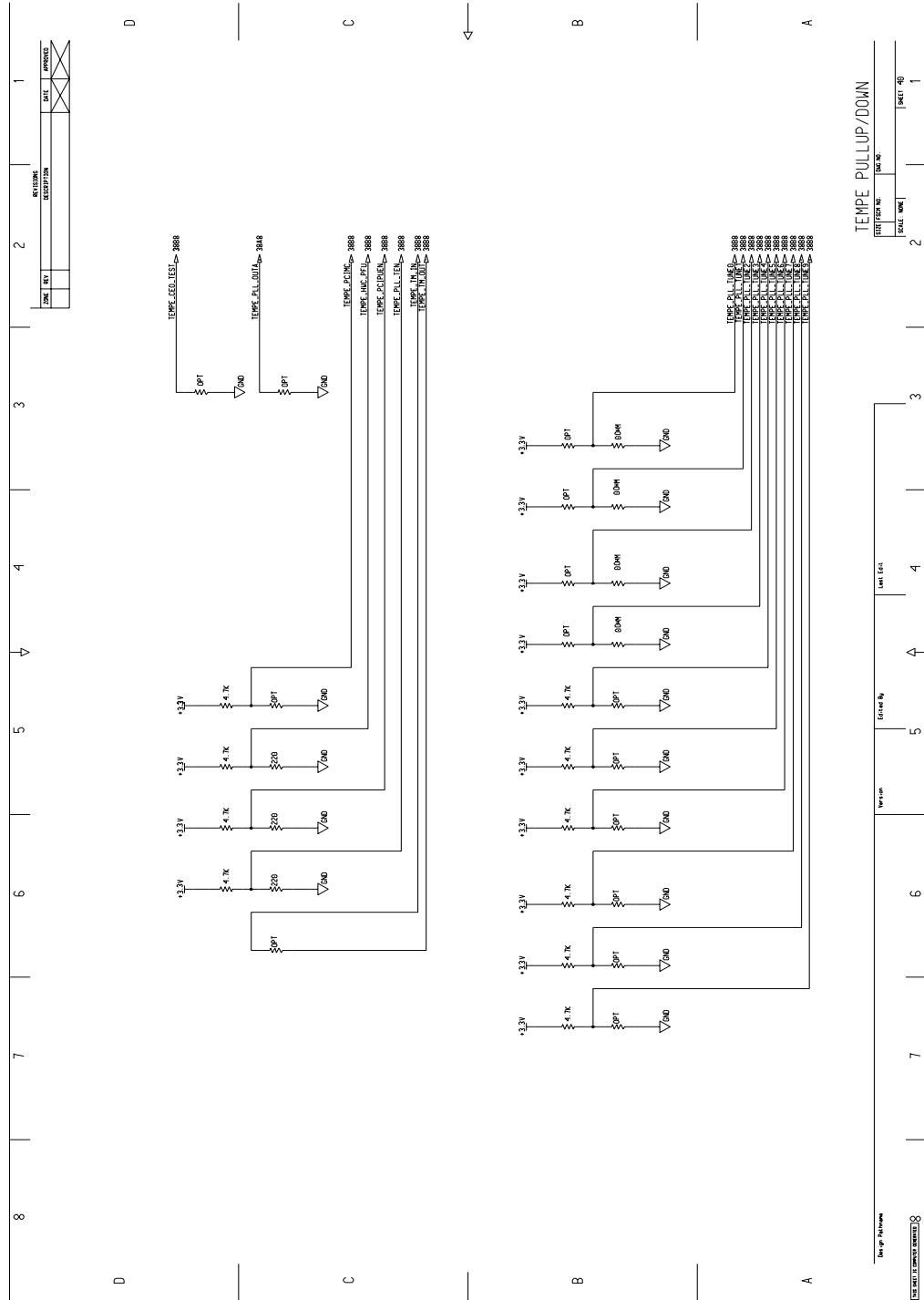

Figure 40: Tsi148 Schematic (Page 40) - Pull-up and Pull-down Requirements



PLL_TUNE[0:3] should be connected to a 0 ohm resistor to ground.

Information in Figure 40 is board dependent. Some boards may not require the pull-up resistors detailed in this schematic.

Figure 41: Tsi148 Schematic (Page 41) - VME Data Buffers

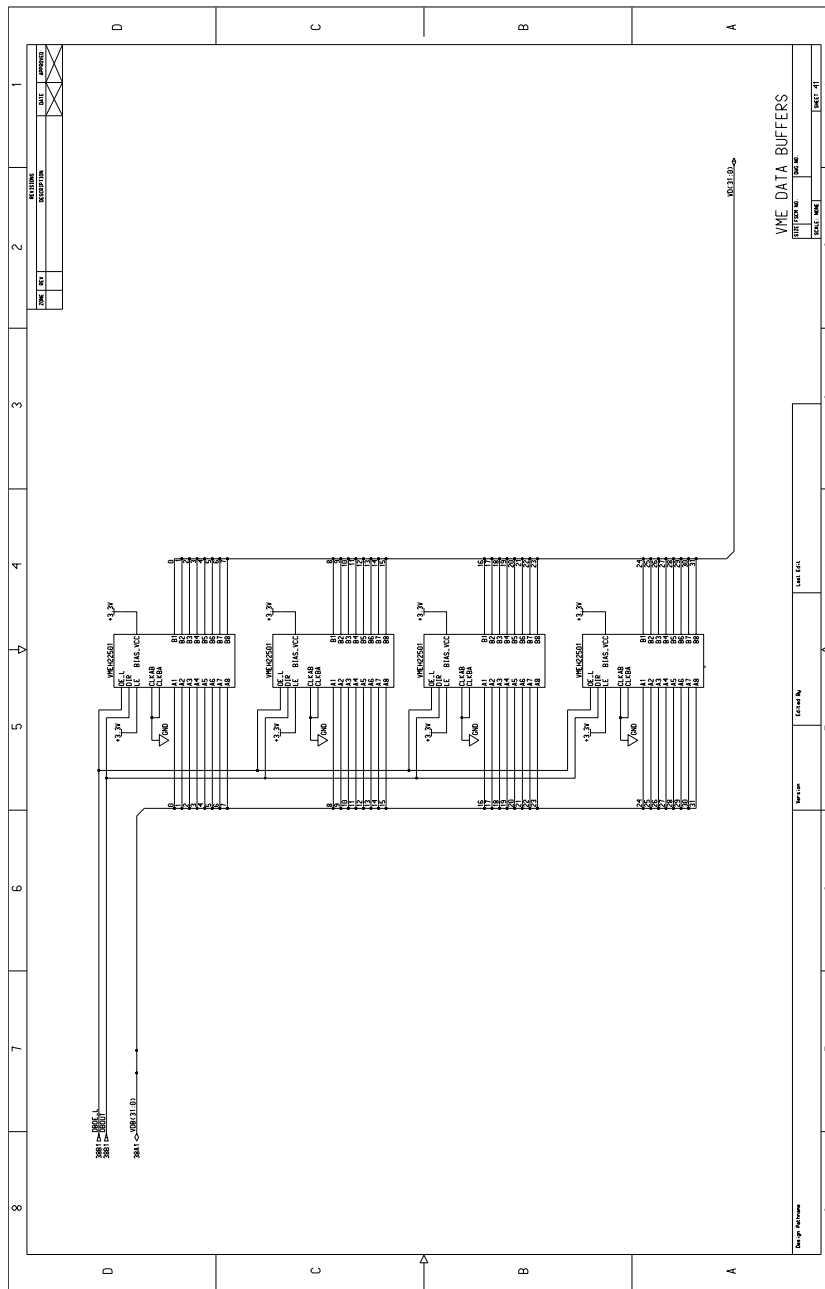

Tundra recommends using 3.3kohm pull-up or pull-down resistors to set the desired level on the VME power-up options on the VD[3:0] pins. This resistor value has been determined to work correctly with the bus hold circuitry on the TISN74VMEH22501/22501A 3A port pins.

For more information on VME power-up options, refer to **“Power-up Options”** on page 128.

Figure 42: Tsi148 Schematic (Page 42) - VME Address Buffers

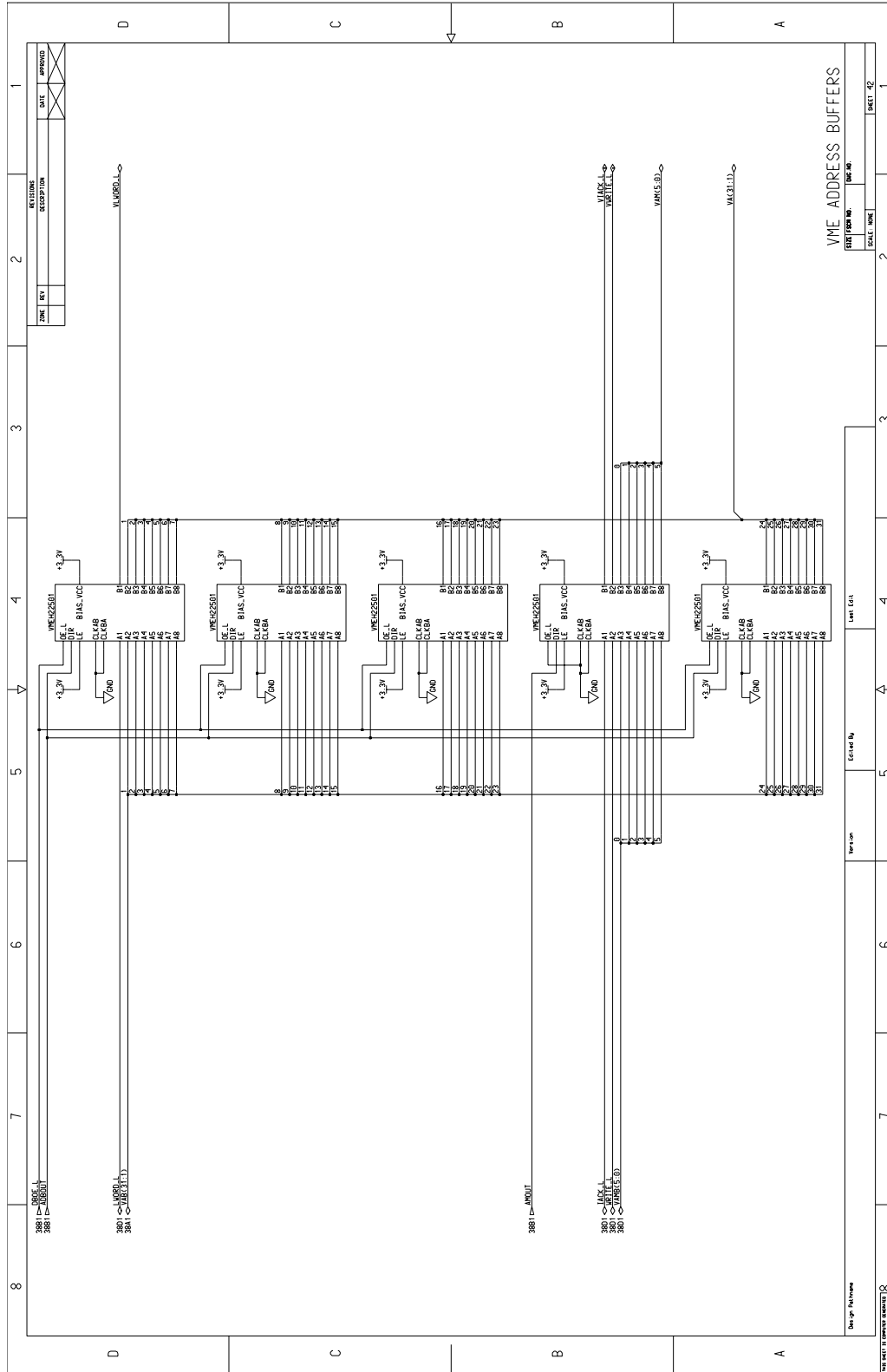

Figure 43: Tsi148 Schematic (Page 43) - VME Control Buffers

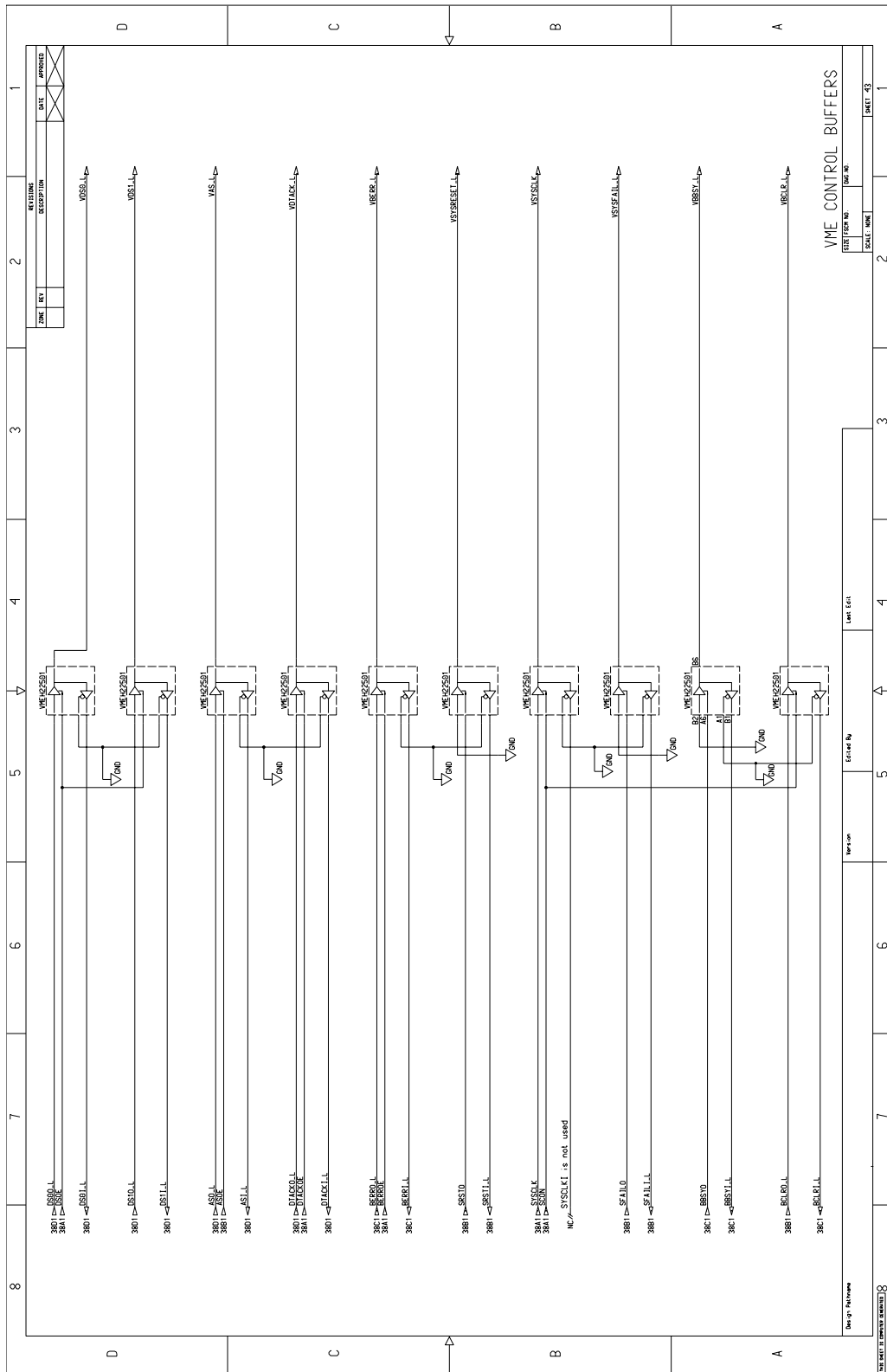

Figure 45: Tsi148 Schematic (Page 45) - VME Transceivers

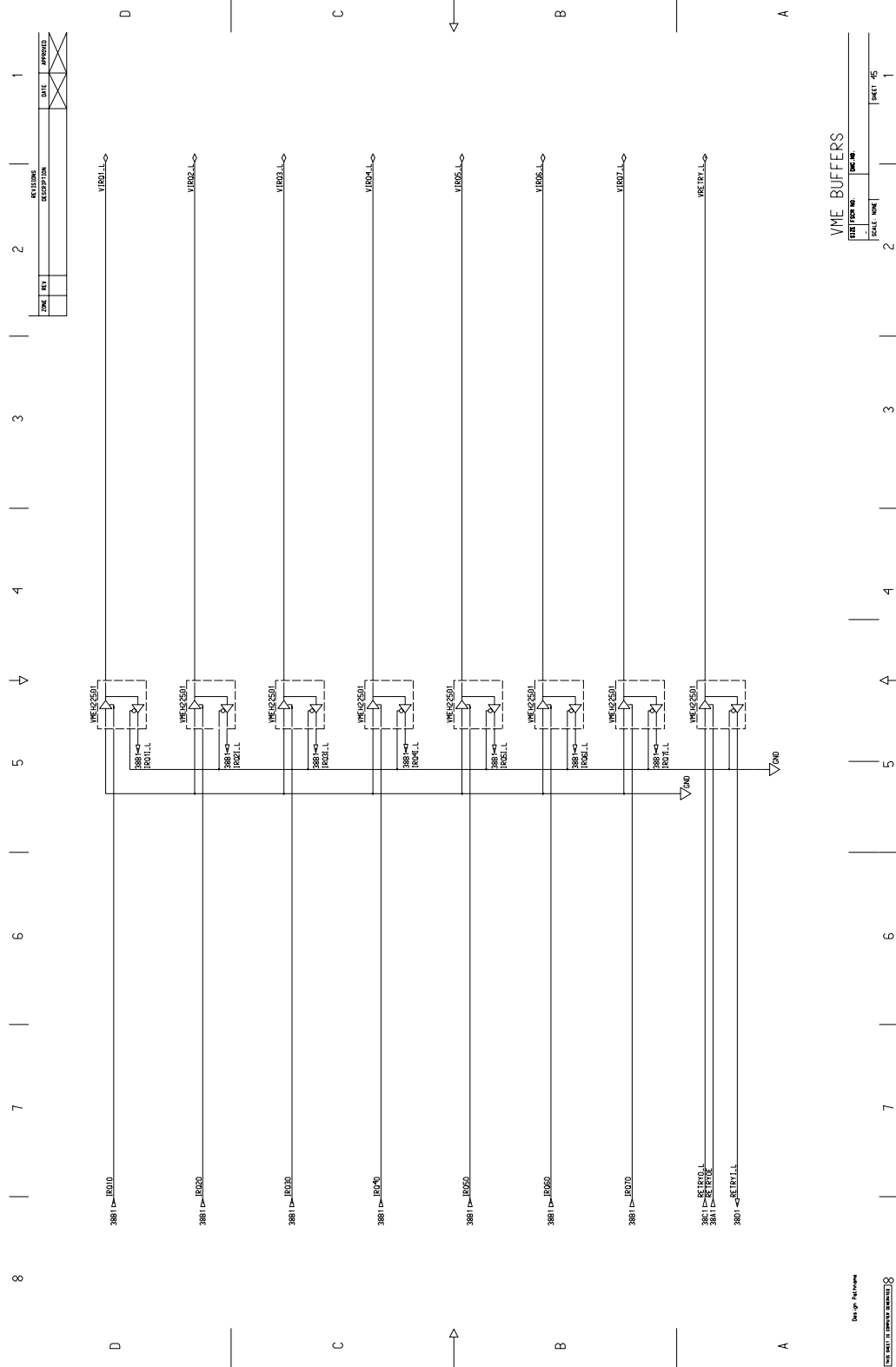

Figure 46: Tsi148 Schematic (Page 56) - PCI Bus 0.0 and 1.0 Pull-ups

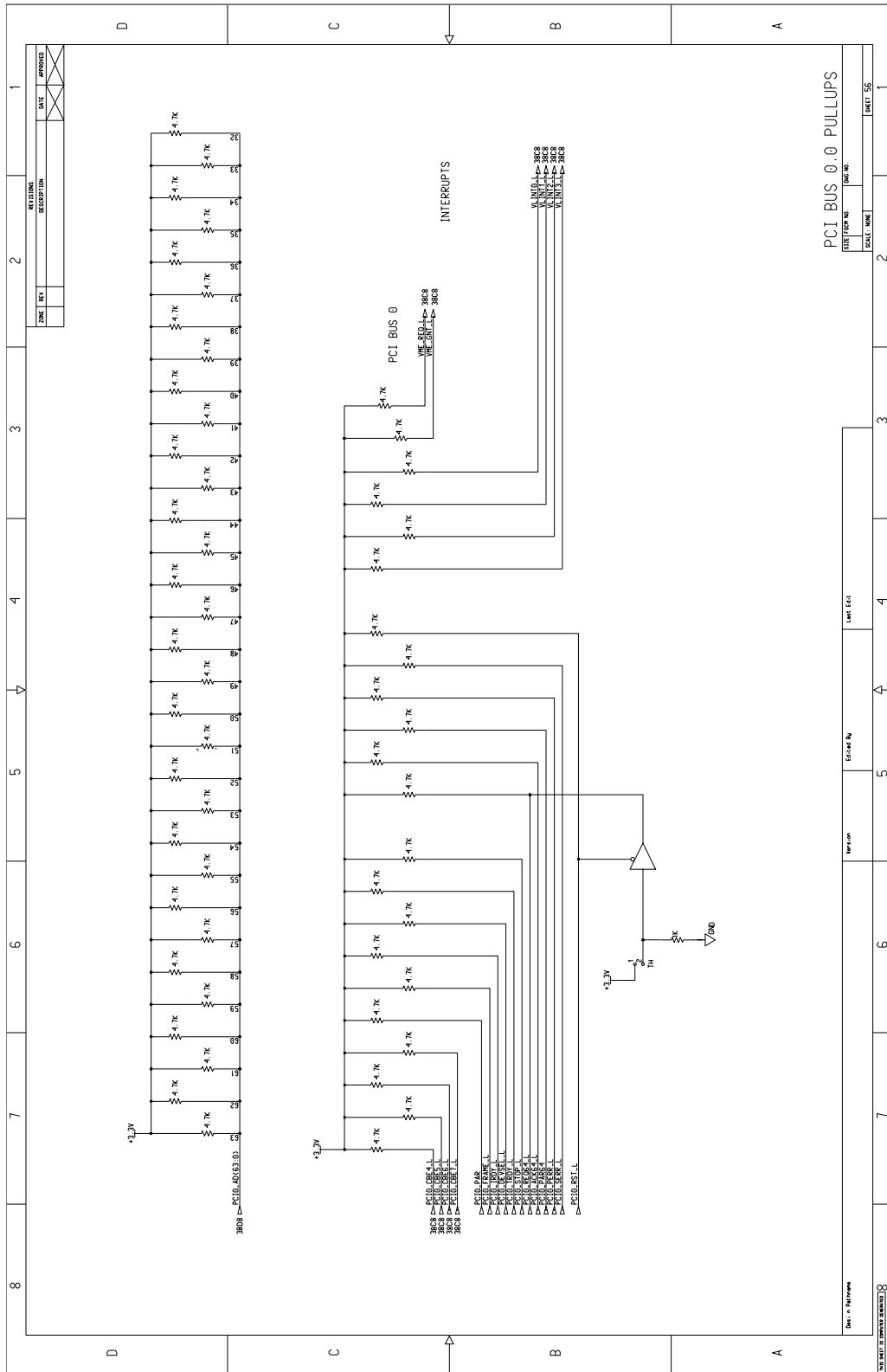
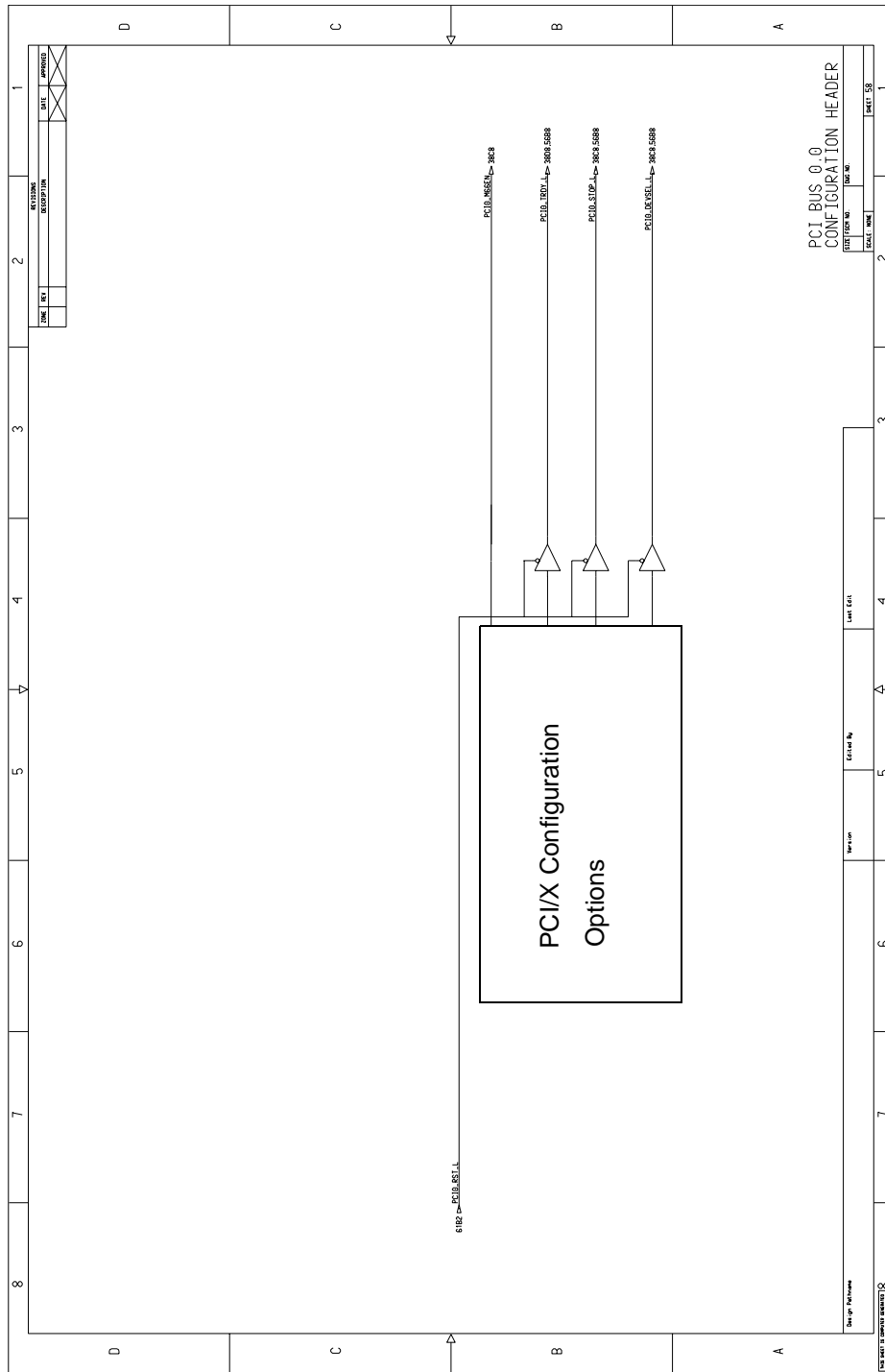

Figure 47: Tsi148 Schematic (Page 58) - PCI Bus 0.0 Configuration Header



For more information on PCI/X power-up options, refer to **“Power-up Options”** on page 128.

B. Hardware Implementation

This chapter discusses the following topics:

- “Tsi148 PLL Filtering” on page 385
 - “Capacitance Decoupling Recommendations” on page 386
 - “Recommended Board Layout Guidelines” on page 387
-

B.1 Tsi148 PLL Filtering

4. The PLL_TUNE0, PLL_TUNE1, PLL_TUNE2 and PLL_TUNE3 signals should be grounded on the board. These signals are adjacent to the PLL power and ground signals. Grounding the tune signals helps shield the PLL power and ground signals.

The PLL tune bits 0, 1, 2 and 3 should have pull up and pull down resistors very close to the package ball. The pull up should not be populated and the pull down should be populated with a zero ohm resistor.

5. The PLL filter shown in [Figure 48](#) should be used.

Figure 48: Recommended PLL Filter

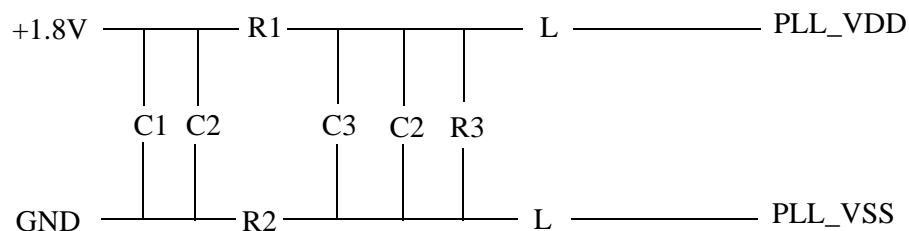

— The following values should be used in conjunction with [Figure 48](#):

- R1 = 2.2 ohm
- R2 = 2.2 ohm
- R3 = not installed
- L = 820 nH
- C1 = 2.2 uF
- C2 = 0.1 uF
- C3 = 10 uF

B.2 Capacitance Decoupling Recommendations

Tundra considers it a good design practice to have decoupling capacitors closely positioned to Tsi148's 3.3V and 1.8V pins. Tundra recommends at least 20 0.1uF ceramic surface mount capacitors on the 3.3V pin and 20 on the 1.8V pin. The inductance of the decoupling capacitors can be minimized by keeping the traces short and wide. For example, the traces should be as wide as the capacitor pad.

B.3 Recommended Board Layout Guidelines

When laying out a board with the Tsi148, the device should be placed as close as possible to the center of the board (that is, placed in between the P1 and P2 connectors). Tundra recommends connecting all Tsi148 VME signals to the VMEbus backplane through the TI TISN74VMEH22501/22501A transceivers.

In order to satisfy VME requirements, all sources of drive on the VMEbus must be no further than two inches from the backplane. This design minimizes any potential loading and reflection problems. Tundra recommends the traces from the TISN74VMEH22501/22501A transceivers to the P1 and P2 connectors be no more than two inches in length. Tundra also recommends the Tsi148 be placed in an orientation on the board that minimizes the distance to the P1 and P2 connectors however, the Tsi148 device orientation is board specific. **Figure 49** shows an example of how the Tsi148 device was oriented in a successful design.

For more information on Tundra board recommendations, refer to the *Tsi148 Schematic Review Checklist* available from the Tundra website at www.tundra.com.

Figure 49: Tsi148 PBGA Orientation

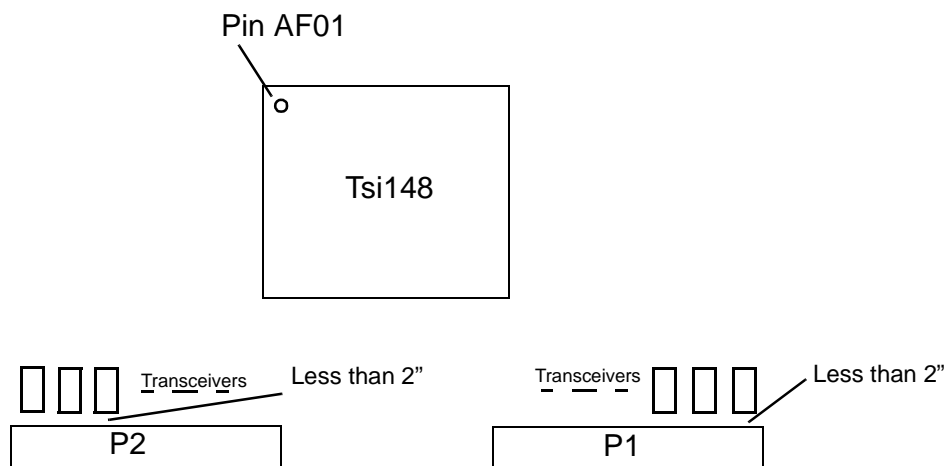

B.3.1 Trace Length Recommendations

It is good design practice to keep all Tsi148 VME signal trace lengths from the device to the transceivers within a 15 to 20 percent nominal spread. For the majority of the Tsi148 signals a trace length an inch to either side of the nominal is recommended. It is also recommended that the inputs and outputs of the key VME control signals (that is, AS, DS0, DS1, DTACK, RETRY, and BERR) be routed with trace lengths equal to the nominal trace length.

B.3.2 Recommended Stackup

The Tsi148 has been designed successfully using an 18 layer PCB Stackup. It may be possible to use a lower layer count, however this design has not been tested. Below is an example of the 18 layer count stackup used on a working Tsi148 board design.

Board Stackup:

1. Signal
2. Signal
3. Signal
4. Signal
5. VSS
6. Signal
7. Signal
8. VSS
9. VDD33
10. VDD18
11. VSS
12. Signal
13. Signal
14. VSS
15. Signal
16. Signal
17. Signal
18. Signal

C. Package Information

This appendix discusses Tsi148's packaging (mechanical) features. The following topic is discussed:

- “Package Characteristics” on page 389

C.1 Package Characteristics

Tsi148's package characteristics are summarized in the following table. [Figure 50](#) illustrates the bottom and side views of the Tsi148 package. [Figure 51](#) presents the top and side views of the device.

Table 176: Package Characteristics

Feature	Description
Package Type	456 PBGA
Package Body Size	27 x 27 mm
JEDEC Specification	MS-034V variation AAL-1

Figure 50: 456-Pin PBGA Package Diagram — Bottom and Side Views

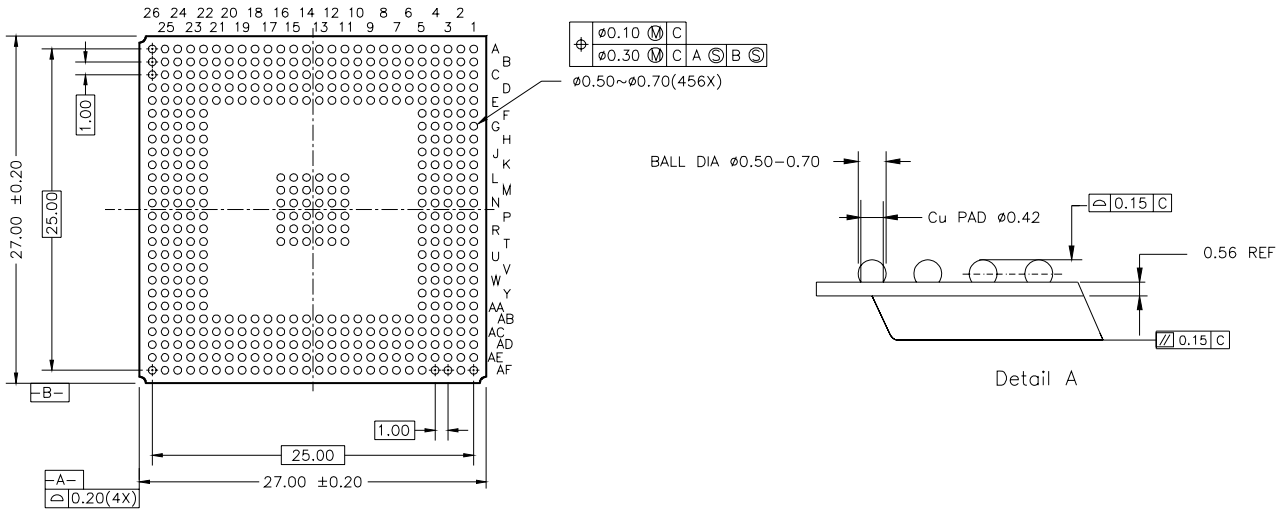
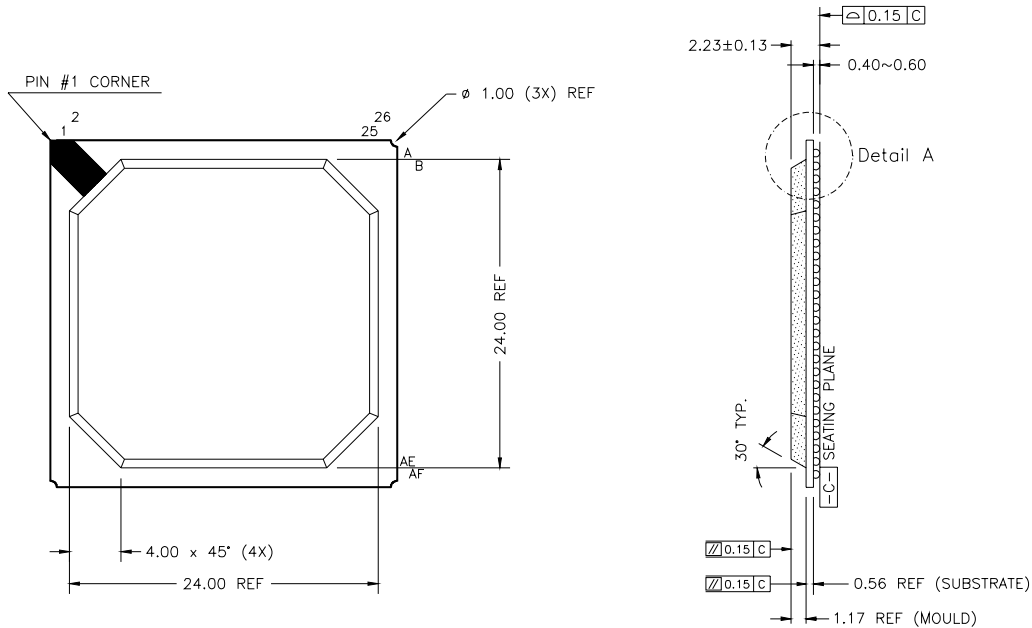

Figure 51: 456-Pin PBGA Package Diagram — Top and Side View



C.1.1 Package Notes

1. All Dimensions are in mm
2. All dimensions and tolerances conform to ANSII14.5M-1994

D. Ordering Information

This appendix discusses Tsi148's ordering information and part numbering system.

D.1 Ordering Information

Tundra products are designated by a product code. When ordering the Tsi148, please refer to the device by its full part number, as displayed in the [Table 177](#).

Table 177: Ordering Information

Part Number	Frequency	Temperature	Package	Pin Count
Tsi148-133CL	133 MHz	Commercial	PBGA	456
Tsi148-133CLY	133MHz	Commercial	PBGA (RoHS)	456
Tsi148-133IL	133 MHz	Industrial	PBGA	456
Tsi148-133ILY	133MHz	Commercial	PBGA (RoHS)	456

D.2 Part Numbering

The Tundra part numbering system is explained as follows.

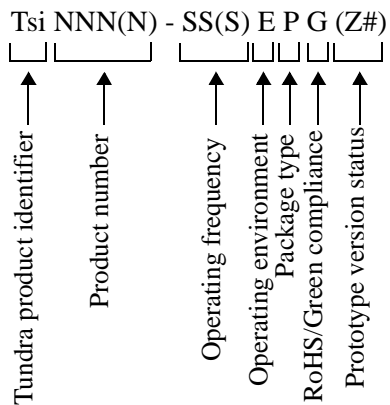

- () – Indicates optional characters.
- Tsi – Tundra system interconnect product identifier. All Tundra semiconductor product numbers start with “Tsi.”
- NNNN – Product number (may be three or four digits).
- SS(S) – Maximum operating frequency or data transfer rate of the fastest interface. For operating frequency numbers, M and G represent MHz and GHz. For transfer rate numbers, M and G represent Mbps and Gbps.
- E – Operating environment in which the product is guaranteed. This code may be one of the following characters:
 - C - Commercial temperature range (0 to +70°C)
 - I - Industrial temperature range (-40 to +85°C)
 - E - Extended temperature range (-55 to +125°C)
- P – The Package type of the product:
 - B - Ceramic ball grid array (CBGA)
 - E, L, J, and K - Plastic ball grid array (PBGA)
 - G - Ceramic pin grid array (CPGA)
 - M - Small outline integrated circuit (SOIC)
 - Q - Plastic quad flatpack (QFP)

- G – Tundra products fit into three RoHS-compliance categories:
 - Y - RoHS Compliant (6of6) – These products contain none of the six restricted substances above the limits set in the EU Directive 2002/95/EC.
 - Y - RoHS Compliant (Flip Chip) – These products contain only one of the six restricted substances: Lead (Pb). These flip-chip products are RoHS compliant through the Lead exemption for Flip Chip technology, Commission Decision 2005/747/EC, which allows Lead in solders to complete a viable electrical connection between semiconductor die and carrier within integrated circuit Flip Chip packages.
 - V - RoHS Compliant/Green - These products follow the above definitions for RoHS Compliance and meet JIG (Joint Industry Guide) Level B requirements for Brominated Flame Retardants (other than PBBs and PBDEs).
- Z# – Prototype version status (optional). If a product is released as a prototype then a “Z” is added to the end of the part number. Further revisions to the prototype prior to production release would add a sequential numeric digit. For example, the first prototype version of device would have a “Z,” a second version would have “Z1,” and so on. The prototype version code is dropped once the product reaches production status.

Bit Index

Numerics

133C 233
2eBS 242
2eOT 271
2eSST 287
2eSSTB 287
2eSSTM0 243, 287
2eSSTM1 243, 287
2eSSTM2 243, 287
2eST 271
2eVME 288
64BCL 307
64BCU 306
64D 233

A

A64DS 253
ABT 331, 336
ACFAILS 261
ACFLC 325
ACFLEN 314
ACFLEO 319
ACFLS 322
ACKD 267
ADMODE0 244
ADMODE1 244
ADMODE2 244
ADMODE3 244
AKFC 267
AM 271
AMODE0 350, 354
AMODE1 350, 354
AMODE2 350, 354
AMODE3 350, 354
AS0 288, 293, 297, 304
AS1 288, 293, 297, 304
AS2 288, 293, 297, 304
ATOEN 257

B

BASEL 224
BASEU 225
BBFC 267
BCFC 267
BCLAS 221
BDFAIL 261
BDFAILS 261, 362, 368, 370
BERR 271

BERRSC 368
BERRSS 370
BGFC 267
BID 257
BIP 310
BIPS 310
BLT 288
BN 233
BPCT 309
BPGT 308
BRFC 267
BSY 337

C

CAPID 231
CAPL 218
CAPP 227
CBAR 372
CBAU 295, 296
CBEAx 278
CCTM 263
CLSZ 222
CNTS 310
COMMx 279
CPURST 261
CROL 300
CROU 299

D

DATA 288, 293, 297, 304
DBW0 244, 350, 353
DBW1 244, 350, 353
DC 233
DCDALx 342
DCDAUx 341
DCLALx 344
DCLAUx 343
DCNT 359
DCSALx 340
DCSAUx 339
DDAL 348
DDAUx 347
DDBS 360
DEVI 217, 361
DEVSELS 264
DGO 331
DHB 253
DLT 257
DMA0C 324
DMA0EN 313
DMA0EO 318
DMA0M 327

DMA0S 321
DMA1C 324
DMA1EN 313
DMA1EO 318
DMA1M 327
DMA1S 321
DMCRS 233
DMMRC 233
DMOST 233
DN 233
DNLALx 358
DNLAU 357
DON 337
DPE 218, 278
DPED 218, 278
DPERE 231
DRQ 263
DS0 271
DS1 271
DSALx 346
DSAUx 345
DTT 278
DTTE 263
DTTT 263
DWB 253

E

EDGIS 310
EDPAL 275
EDPAU 274
EDPCL 278
EDPOF 278
EDPST 278
EDPXA 276
EDPXS 277
EN 243, 287, 293, 297, 301, 304
ENDAL 284
ENDL 239
ENDU 238, 283
ERO 231
ERR 336
ERRS 337
ERT0 337
ERT1 337

F

FAST 218
FN 233
FRAMES 264

G

GA 261, 363

GAP 261, 362
GBAU 291
GTO 257

H

HEAD 222

I

IACK 271
IACKC 324
IACKEN 313
IACKEO 318
IACKS 321
INTL 228
INTP 228
IO/MEM 224
IOSP 219
IRDYS 264
IRQ1EN 314
IRQ1EO 319
IRQ1M 329
IRQ1S 322
IRQ2EN 314
IRQ2EO 319
IRQ2F 310
IRQ2M 329
IRQ2S 322
IRQ3EN 314
IRQ3EO 319
IRQ3M 329
IRQ3S 322
IRQ4EN 314
IRQ4EO 319
IRQ4M 329
IRQ4S 322
IRQ5EN 314
IRQ5EO 319
IRQ5M 329
IRQ5S 322
IRQ6EN 314
IRQ6EO 319
IRQ6M 329
IRQ6S 322
IRQ7EN 314
IRQ7EO 319
IRQ7M 329
IRQ7S 322
IRQC 310
IRQIF 310
IRQL 310
IRQLS 310
IRQS 310

L

LLA 358
LM0C 324
LM0EN 313
LM0EO 318
LM0M 327
LM0S 321
LM1C 324
LM1EN 313
LM1EO 318
LM1M 327
LM1S 321
LM2C 324
LM2EN 313
LM2EO 318
LM2M 327
LM2S 321
LM3C 324
LM3EN 313
LM3EO 318
LM3M 327
LM3S 321
LMBAL 303
LMBAU 302
LMI0S 362
LMI1S 362
LMI2S 362
LMI3S 362
LRESET 257
LRST 362
LRSTC 368
LRSTS 370
LWORD 271

M

M66ENS 264
MB0C 324
MB0EN 313
MB0EO 318
MB0M 327
MB0S 321
MB1C 324
MB1EN 313
MB1EO 318
MB1M 327
MB1S 321
MB2C 324
MB2EN 313
MB2EO 318
MB2M 327
MB2S 321
MB3C 324

MB3EN 313
MB3EO 318
MB3M 327
MB3S 321
MBI0S 362
MBI1S 362
MBI2S 362
MBI3S 362
MBLT 288
MBOX 367
MEMSP 219
MEN 362
MENC 368
MENS 370
MLAT 222
MMRBC 231
MNGN 228
MOD 331
MOST 231
MRC 263, 278
MRCE 264
MRCT 263
MRPFD 243
MSTR 219
MTYP0 224
MTYP1 224
MXLA 228

N

NCAPP 231
NELBB 257
NIN 349
NPRIV 288, 293, 297, 304

O

OFFL 241, 286, 292
OFFU 240, 285

P

P66M 218
PAU 331, 336
PBKS 331
PBOT 332
PERR 219
PERRC 324
PERREN 313
PERREO 318
PERRS 321
PFAR 331
PFS0 243
PFS1 243
PGM 244, 288, 293, 297, 304, 350, 354

PIC 221
PRE 224
PSZ 349
PURSTS 261

R

RCVMA 218
RCVTA 218
REQ64S 264
REVI 221
REVID 363
RMA 278
RMWAL 249
RMWAU 248
RMWC 251
RMWEN 250, 253
RMWS 252
ROBIN 257
RSCEM 233
RTA 278

S

SBH 263
SCD 233, 278
SCEM 278
SCLAS 221
SCONS 261, 362
SELTIM0 218
SELTIM1 218
SEMA0 365
SEMA1 365
SEMA2 365
SEMA3 365
SEMA4 366
SEMA5 366
SEMA6 366
SEMA7 366
SERR 219
SFAILAI 257
SFAILC 368
SFAILEN 362
SFAILS 370
SIGSE 218
SIGTA 218
SRESET 257
SRT 278
SRTE 263
SRTO 263
SRTTS 263
SSTM0 349, 353
SSTM1 349, 353
STAL 237, 282

STAU 236, 281
STFC 267
STID 310
STOPS 264
SUBI 226
SUBV 226
SUP 244, 350, 353
SUPR 288, 293, 297, 304
SYSFLC 325
SYSFLEN 314
SYSFLEO 319
SYSFLS 261, 322

T

TH 287
TM0 244, 350, 353
TM1 244, 349, 353
TM2 243, 349, 353
TRSDYS 264
TYP 353
TYP0 349
TYP1 349

U

USC 233, 278

V

VBKS 331
VBOT 331
VEAL 270
VEAU 269
VENI 217, 361
VEOF 271
VERRC 324
VERREN 313
VERREO 318
VERRS 321
VES 271
VESCL 271
VFAIR 254
VFAR 331
VFS0 287
VFS1 287
VIACK 247
VIEC 324
VIEEN 313
VIEEO 318
VIES 321
VREL 254
VREQL 254
VS 253
VSA 253

VTOFF 253
VTON 254

W

WRITE 271

X

XAM 271

Index

Numerics

2eSST Protocol [34](#)
2eVME Protocol [34](#)
64BCL register [307](#)
64BCU register [306](#)

A

ACFAILI_ signal [157](#)
ACK64_ signal [151](#)
AD signals [148](#)
ADBOU signal [157](#)
AM0 signal [154](#)
AM1 signal [154](#)
AM2 signal [154](#)
AM3 signal [154](#)
AM4 signal [154](#)
AM5 signal [154](#)
AMOUT signal [157](#)
ASI_ signal [155](#)
ASO_ signal [155](#)
ASOE signal [157](#)

B

BBSYI_ signal [156](#)
BBSYO signal [156](#)
BCLRI_ signal [156](#)
BCLRO_ signal [156](#)
BDFAIL_ signal [152](#)
BERRI_ signal [155](#)
BERRO_ signal [155](#)
BERROE signal [157](#)
BG0IN_ signal [155](#)
BG0INOUT_ signal [155](#)
BG0OUT_ signal [156](#)
BG1IN_ signal [155](#)
BG1INOUT_ signal [156](#)
BG1OUT_ signal [156](#)
BG2IN_ signal [155](#)

BG2INOUT_ signal [156](#)
BG2OUT_ signal [156](#)
BG3IN_ signal [155](#)
BG3INOUT_ signal [156](#)
BG3OUT_ signal [156](#)
BPCTR register [309](#)
BPGTR register [308](#)
BR0I_ signal [155](#)
BR0O signal [155](#)
BR1I_ signal [155](#)
BR1O signal [155](#)
BR2I_ signal [155](#)
BR2O signal [155](#)
BR3I_ signal [155](#)
BR3O signal [155](#)

C

CAPP register [227](#)
CBAL register [296](#)
CBAR register [372](#)
CBAU register [295](#)
CBE0_ signal [150](#)
CBE1_ signal [150](#)
CBE2_ signal [151](#)
CBE3_ signal [151](#)
CBE4_ signal [151](#)
CBE5_ signal [151](#)
CBE6_ signal [151](#)
CBE7_ signal [151](#)
CEO_TEST signal [158](#)
CLAS/REVI register [221](#)
clocks [121](#)
contact information [5](#)
CRAT register [301](#)
CRGAT register [297](#)
CROL register [300](#)
CROU register [299](#)
CSRBCR register [368](#)
CSRBSR register [370](#)
customer support information [5](#)

D

DBOE_ signal 157
DBOUT signal 157
DCALx register 346
DCDALx register 342
DCDAUx register 341
DCLALx register 344
DCLAUx register 343
DCNTx register 359
DCSALx register 340
DCSAUx register 339
DCTLx register 331
DDALx register 348
DDATx register 353
DDAUx register 347
DDBSx register 360
DEVI/VENI register 217, 361
DEVSEL_ signal 151
direct memory access (DMA) 99
DMA (direct memory access) 99
DMA Controller 100
 Architecture 100
 Buffers 100
 Direction of Data Movement 104
 Operating Modes 101
 Direct mode 101
 Linked-list mode 101
 Transaction Termination 118
 Commanded Abort 118
 Commanded Stop 118
 Detected Error Abort 119
 Transfer Completion 118
DMA Controllers Overview 44
DNLALx register 358
DNLAUx register 357
document conventions 23
 signals 23
DS0I_ signal 155
DS0O_ signal 155
DS1I_ signal 155
DS1O_ signal 155
DSATx register 349
DSAUx register 345
DSOE signal 157
DSTAx register 336
DTACKI_ signal 155
DTACKO_ signal 155
DTACKOE signal 157

E

EDPAL register 275
EDPAT register 278

EDPAU register 274
EDPXA register 276
EDPXS register 277
electrical characteristics 185
endian mapping 24

F

FRAME_ signal 151
functional overview 29, 47, 71

G

GA0_ signal 157
GA1_ signal 157
GA2_ signal 157
GA3_ signal 157
GA4_ signal 157
GAP_ signal 157
GBAL register 292
GBAU register 291
GCSRAT register 293
GCTRL register 362
GNT_ signal 151

H

HEAD/MLAT/CLSZ register 222
HWC_PFU signal 158

I

IACK_ signal 154
IACKIN_ signal 156
IACKOUT_ signal 156
IDSEL signal 151
IITOFI register 286
INTA_ signal 151
INTB_ signal 151
INTC register 324
INTC_ signal 151
INTD_ signal 151
INTEN register 313
INTEO register 318
interrupts 137
INTM1 register 327
INTM2 register 329
INTS register 321
IRDY_ signal 151
IRQ1I_ signal 156
IRQ1O signal 156
IRQ2I_ signal 156
IRQ2O signal 156
IRQ3I_ signal 156
IRQ3O signal 156
IRQ4I_ signal 156

IRQ40 signal 156
IRQ5L_ signal 156
IRQ5O signal 156
IRQ6L_ signal 156
IRQ6O signal 156
IRQ7L_ signal 156
IRQ7O signal 157
ITATx register 287
ITEALx register 284
ITEAUx register 283
ITOFUx register 285
ITSALx register 282
ITSAUx register 281

J

JTAG 46, 141
 Instructions 142

L

Linkage Module 41
LMAT register 304
LMBAL register 303
LMBAU register 302
Local Interrupter 138
LRSTI_ signal 152
LRSTO_ signal 152
LSRSTI_ signal 152
LWORD_ signal 155

M

M66EN signal 151
 mailing address 6
MBAR register 224
MBARU register 225
MBOXx register 367
 mechanical information 389
MXLA/MNGN/INTP/INTL register 228

O

 ordering information 391
OTATx register 243
OTBSx register 242
OTEALx register 239
OTEAUx register 238
OTOFLx register 241
OTOFUx register 240
OTSALx register 237
OTSAUx register 236

P

 packaging information 389
PAR signal 151

PAR64 signal 151
PCI Address/Data Bus signals 148
PCI Bus Exception Handling 84
 Master 84
 Target 84
PCI Master 83
 Bandwidth Control 83
 Buffers 83
 Commands 83
PCI Target 72
 Buffers 72
 Commands 74
 Read Transaction 75
 Transaction Mapping 73
 Write Transaction 80
PCI/X Bus Exception Handling 97
 Master 97
 Target 98
PCI/X Interface Overview 39
PCIMC signal 158
PCIPUEN signal 158
PCI-X Master 96
 Bandwidth Control 96
 Buffers 96
PCI-X Target 86
 Buffers 86
 Commands 88
 Read Transaction 89
 Transaction Mapping 87
 Transactions 88
 Write Transaction 93
PCIXCAP register 231
PCIXSTAT register 233
PCLK signal 151
PCSR register 263
PERR_ signal 151
PLL_OUTA signal 158
PLL_RSTI_ signal 158
PLL_TEN signal 158
PLL_TUNE0 signal 158
PLL_TUNE1 signal 158
PLL_TUNE2 signal 158
PLL_TUNE3 signal 158
PLL_TUNE4 signal 158
PLL_TUNE5 signal 158
PLL_TUNE6 signal 158
PLL_TUNE7 signal 158
PLL_TUNE8 signal 158
PLL_TUNE9 signal 158
PLL_VDD signal 158
PLL_VSS signal 159
Power-up Options

- PCI/X 128
- VMEbus 130
- power-up options 121
- product benefits 32
- product code 391
- product features 31
- PURSTI_ signal 152

R

- registers 195
- Registers Overview 42
- related documentation 28
- REQ_ signal 151
- REQ64_ signal 151
- resets 121
- RETRYI_ signal 155
- RETRYO_ signal 155
- RETRYOE signal 157
- RMWAL register 249
- RMWAU register 248
- RMWC register 251
- RMWEN register 250
- RMWS register 252

S

- sales support 6
- SCON signal 157
- SCONDIS_ signal 157
- SCONEN_ signal 157
- SEMAR0 register 365
- SEMAR1 register 366
- SERR_ signal 151
- SFAILI_ signal 157
- SFAILO signal 157
- Signal Description 160
- signals 145, 385
- Spares signal 159
- SRSTI_ signal 157
- SRSTO signal 157
- STAT/CMMD register 218
- STOP_ signal 151
- SUBI/SUBV register 226
- SYSCLK signal 157

T

- TCK signal 158
- TDI signal 158
- TDO signal 158
- TM_IN signal 158
- TM_OUT signal 158
- TMS signal 158
- TRDY_ signal 151

- TRST_ signal 158
- typical applications 32, 373

V

- VA signals 152
- VCTRL register 257
- VD1 signal 153
- VDD18 signal 159
- VDD33 signal 159
- VEAL register 270
- VEAT register 271
- VEAU register 269
- VIACKx register 247
- VICR register 310
- VMCTRL register 253
- VME Master 59
 - Bandwidth Control 62
 - Buffers 60
 - Read-Modify Write (RMW) Cycles 60
 - Release Conditions 63
- VME Master Interface Overview 36
- VME Slave 48
 - Buffers 48
 - Read Transaction 52
 - Read-Modify Write (RMW) Cycles 58
 - Terminations 58
 - Transaction Mapping 49
 - Transactions 52
 - Write Transaction 56
- VME Slave Interface Overview 35
- VMEbus
 - Interrupter and Interrupt Handler 45
- VMEbus Address Bus signals 152
- VMEbus Data Bus signals 153
- VMEbus Interface 48
- VMEbus Interrupt Handler 139
- VMEbus Interrupter 138
- VMEbus System Controller
 - Arbiter 37, 69
 - Configuration 38, 70
 - Global VMEbus Timer 38, 70
 - SYSRESET Driver 38, 69
 - System Clock Driver 38, 70
- VMEFL register 267
- VSS signal 159
- VSTAT register 261

W

- webpages 5
- WRITE_ signal 154